

HUSSMANN®



GSVM *Medium Temperature Self Contained Open Vertical Merchandisers*



Installation & Service Manual

IMPORTANT
Keep in store
for future reference!

MANUAL -I/O Self Contained GSVM

P/N 0545716_A
June 2014

Spanish 0545717
French 0545718

ATTENTION

Merchandiser must operate for 24 hours
before loading product!

Regularly check merchandiser temperatures.

Do not break the cold chain. Keep products
in cooler before loading into merchandiser.

These merchandisers are designed
for pre-chilled products only.



IMPORTANT
KEEP IN STORE FOR FUTURE REFERENCE
Quality that sets industry standards!

12999 St. Charles Rock Road • Bridgeton, MO 63044-2483

U.S. & Canada 1-800-922-1919 • Mexico 01 800-890-2900

www.hussmann.com

© 2014 Hussmann Corporation

TABLE OF CONTENTS

v

ANSI DEFINITIONS vi

INSTALLATION

Certification 1-1
Husmann Product Control 1-1
Shipping Damage 1-1
Location 1-1
Self Contained Location 1-2
Model Description 1-3
Unloading 1-3
Exterior Loading 1-3
Shipping Skid 1-3
Merchandiser Leveling 1-4
Optional Legs 1-4
Serial Plate Location 1-4
Refrigeration Unit Access 1-4
Sealing Merchandiser to Floor 1-4
Night Curtain Installation 1-5
Checklists 1-7

ELECTRICAL / REFRIGERATION

Merchandiser Electrical Data 2-1
Field Wiring 2-1
Power Switch 2-1
Electrical Connections 2-1
Electrical Outlet 2-1
Refrigeration (Self Contained) 2-2
Waste Outlet and Water Seal 2-2
Safe-NET III Controller 2-3
Safe-NET Display 2-4
Safe-NET Start-Up 2-4
Sequence of Operation 2-5
Alarms and Codes 2-6
Defrost Termination Switch 2-6
Temperature Adjustment 2-7

START UP / OPERATION

Start-Up 3-1
TEV Adjustment 3-1
Controls and Adjustments 3-2
Load Limits 3-3
Stocking 3-3
Solar Thermometer 3-3
Shelf Weight Limits 3-4

MAINTENANCE

Care and Cleaning 4-1
Do NOT Use: 4-1
Do: 4-1
Removing Scratches from Bumper 4-2
Cleaning Discharge Honeycomb 4-2
Cleaning Under Display Pan 4-3
Cleaning Evaporation Pan 4-3
Cleaning Coils 4-4
Removing Scratches from Bumper 4-4
Maintaining Fluorescent Lamps 4-4

SERVICE

Replacing Fan Motors and Blades 5-1
Replacing Fluorescent Lamps 5-2
Repairing Aluminum Coil 5-2
Troubleshooting Guide 5-3
GSVM Accessories 5-4
Definitions 5-5

APPENDIX

Part Numbers A-1
Plan View A-2
Cross Sections and Refrigeration Data .. A-3
Electrical Data A-4
Shipping Weights and Amps A-5
Wiring Diagram GSVM-4060 A-6
Wiring Diagram GSVM-4072 A-7
Wiring Diagram GSVM-5272 A-8

WARRANTY

REVISION HISTORY

ORIGINAL ISSUE — *June 2014*

ANSI Z535.5 DEFINITIONS



• **DANGER** – Indicate[s] a hazardous situation which, if not avoided, will result in death or serious injury.



• **WARNING** – Indicate[s] a hazardous situation which, if not avoided, could result in death or serious injury.



• **CAUTION** – Indicate[s] a hazardous situation which, if not avoided, could result in minor or moderate injury.

• **NOTICE** – *Not related to personal injury* – Indicates[s] situations, which if not avoided, could result in damage to equipment.

INSTALLATION

CERTIFICATION

These merchandisers are manufactured to meet ANSI / National Sanitation Foundation (NSF®) Standard #7 requirements. Proper installation is required to maintain certification. Near the serial plate, each case carries a label identifying the type of application for which the case was certified.

ANSI/NSF-7 Type I - Display Refrigerator / Freezer

Intended for 75°F / 55% RH Ambient Application

ANSI/NSF-7 Type II - Display Refrigerator / Freezer

Intended for 80°F / 55% RH Ambient Application

ANSI/NSF-7 - Display Refrigerator

Intended for Bulk Produce

HUSSMANN PRODUCT CONTROL

The serial number and shipping date of all equipment is recorded in Hussmann's files for warranty and replacement part purposes. All correspondence pertaining to warranty or parts ordering must include the serial number of each piece of equipment involved. This is to ensure the customer is provided with the correct parts.

SHIPPING DAMAGE

All equipment should be thoroughly examined for shipping damage before and during unloading. This equipment has been carefully inspected at our factory. Any claim for loss or damage must be made to the carrier. The carrier will provide any necessary inspection reports and/or claim forms.

Apparent Loss or Damage

If there is an obvious loss or damage, it must be noted on the freight bill or express receipt and signed by the carrier's agent; otherwise, carrier may refuse claim.

Concealed Loss or Damage

When loss or damage is not apparent until after equipment is uncrated, retain all packing materials and submit a written response to the carrier for inspection within 15 days.

LOCATION

These merchandisers are designed for displaying products in air conditioned stores where temperature is maintained at or below the ANSI / NSF-7 specified level and relative humidity is maintained at or below 55%.

<p>Recommended operating ambient temperature is between 65°F (18°C) to 80°F (26.6°C). Maximum relative humidity is 55%.</p>
--

Placing refrigerated merchandisers in direct sunlight, near hot tables or near other heat sources could impair their efficiency. Like other merchandisers, these merchandisers are sensitive to air disturbances. Air currents passing around merchandisers will seriously impair their operation. Do NOT allow air conditioning, electric fans, open doors or windows, etc. to create air currents around the merchandiser.

1-2 INSTALLATION

SELF CONTAINED (LOCATION)

GSVM-4060 and GSVM-4072 (at 75°F/55% relative humidity, maximum ambient conditions) has front condenser air intake and discharge. Maintain a minimum clearance distance of two feet in front of the merchandiser so that air discharge and air intake is not obstructed.

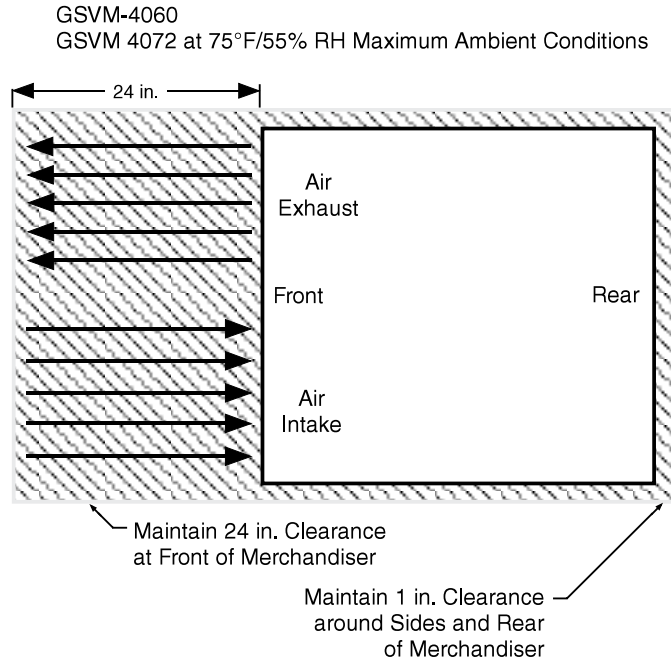

GSVM-4072 (at 80°F/55% relative humidity, maximum ambient conditions) and **GSVM-5272** each require a 5 inch minimum clearance behind the merchandiser and clearance above the merchandiser since its air flows straight through the condensing unit compartment. Brackets are provided for field attachment to obtain this rear 5 inch minimum clearance.

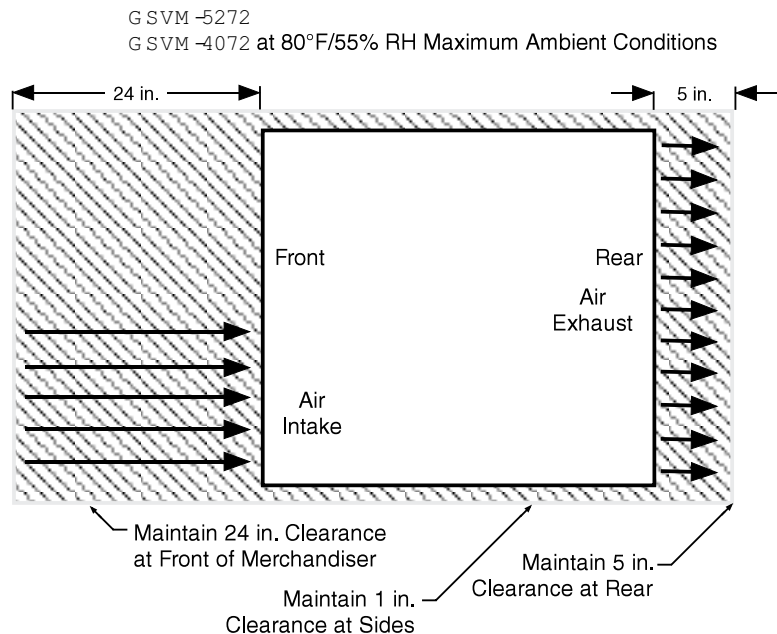

MODEL DESCRIPTION

The GSVM open vertical merchandiser offers versatility in the display of medium temperature (32° F to 41° F) products such as dairy products, prepared salads, pizza and fresh entrees that are pre-chilled in a cooler. Carefully read and follow the instructions prior operating the merchandiser.

UNLOADING

Unloading from Trailer:

Lever Bar (also known as a Mule, Johnson Bar, J-bar, Lever Dolly, or Pry Lever)

Move the merchandiser as close as possible to its permanent location and remove all packaging. Check for damage before discarding packaging. Remove all separately packed accessories such as kits and shelves. Improper handling may cause damage to the merchandiser when unloading to avoid damage:



CAUTION

Do not walk or put heavy objects on case.

1. Do not drag the merchandiser out of the trailer. Use a Johnson bar (mule).
2. Use a forklift or dolly to remove the merchandiser from the trailer.

EXTERIOR LOADING

Do NOT walk on top of merchandisers or damage to the merchandisers and serious personal injury could occur.

MERCHANDISERS ARE NOT STRUCTURALLY DESIGNED TO SUPPORT EXTERNAL LOADING such as the weight of a person. Do not place heavy objects on the merchandiser.

HUSSMANN CORPORATION • BRIDGETON, MO 63044-2483 U.S.A.

SHIPPING SKID

Each merchandiser is shipped on a skid to protect the merchandiser's base, and to make positioning the case easier.

Do not remove the shipping skid until the merchandiser is near its final location. The skid provides protection for both the merchandiser and the floor.

Remove the skid by raising one end of the merchandiser approximately 6 inches. Block the merchandiser securely, and remove the two skid bolts from the raised end. Replace the bolts with (provided) leg levelers. Repeat this procedure at opposing end. Once the leg levelers are secured in place, the merchandiser may be slid off the skid and placed in its final location.

DO NOT TILT MERCHANDISER ON ITS SIDE OR END WHEN REMOVING SKID.

Once the skid is removed, the merchandiser must be lifted —NOT PUSHED— to reposition.

Check floor where merchandisers are to be set to see if it is a level area. Determine the highest part of the floor.



WARNING

Do NOT remove shipping crate until the merchandiser is positioned for installation.



WARNING

Do NOT stand or walk on top of merchandiser. Do not store items or flammable materials atop the unit.

GSVM Open Vertical Merchandisers

1-4 INSTALLATION

MERCHANDISER LEVELING

BE SURE TO POSITION MERCHANDISERS PROPERLY. Level the merchandiser by all four corners. Merchandiser(s) must be installed level to ensure proper operation of the refrigeration system, and to ensure proper drainage of defrost water.

OPTIONAL LEGS

NSF® approved legs replace the leg levelers if required by local health codes. The legs raise the case 6 inches for cleaning purposes. An optional skirt kit can be provided to snap on the legs.

SERIAL PLATE LOCATION

The serial plate is located on the interior top, left side of the merchandiser. It contains all pertinent information such as model, serial number, amperage rating, refrigerant type and charge. This information will be needed to install, service or order parts for the merchandiser.



REFRIGERATION UNIT ACCESS

The lower front panel may be removed by removing screw at bottom and lifting the panel straight upward and over the tabs on which it is hanging. The panel is installed by reversing the above procedure.

Ensure lower front panel is flat against the floor when installed to prevent air circulation problems for self contained merchandisers.

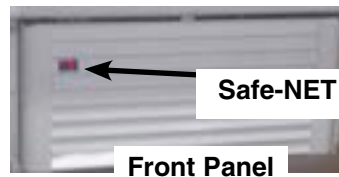

Lift up and out to remove access panel



Safe-NET III display is mounted on left side of access panel. Be careful not to detach Safe-NET III cable from display when removing access panel.



SEALING MERCHANDISER TO FLOOR

If required by local sanitary codes, or if the customer desires, merchandisers may be sealed to the floor using a vinyl cove base trim. The size needed will depend on how much variation there is in the floor, from one end of the merchandiser to the other. Sealing of the lower front and rear panels on self contained models may hamper their removal for servicing or maintenance of the condensing unit.

NOTE: Do not allow trim to cover any intake or discharge grilles located in the lower front panel.

NIGHT CURTAIN INSTALLATION

Night curtains are used to cover the case opening after normal business hours. The curtains improve energy consumption, allowing the refrigeration system to work less.

Fasten night curtain to top panel using (3) #8 x 1/2 in. screws.

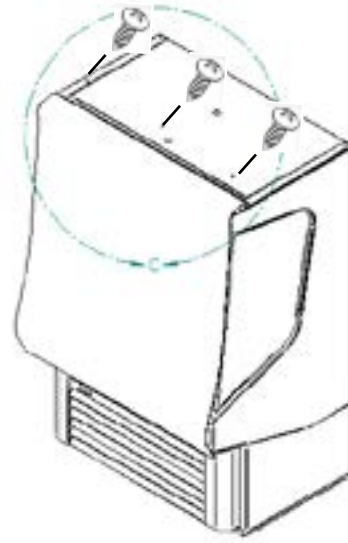

Carefully inspect the night curtain kit to ensure there is no damage from breakage during shipping. Case should be positioned and leveled before installing the night curtain.

Position night curtain on top panel. Measure 21 inches to edge of the end night curtain. Center night curtain to length of case.

The night curtain for GSVM is standard for model 5272 and is an optional kit for models 4060 and 4072.

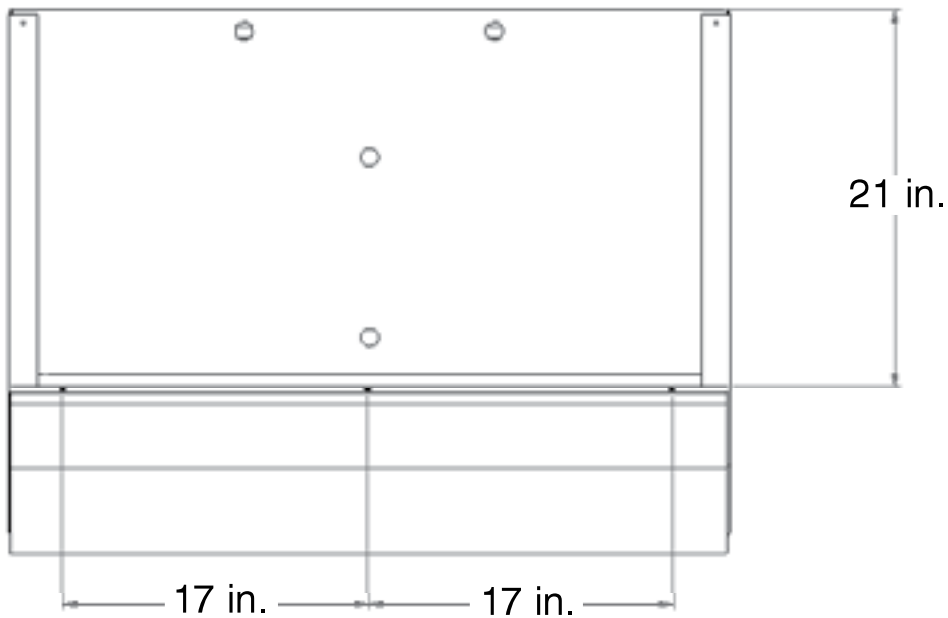

1-6 INSTALLATION

Secure bottom of night curtain using bottom clip as shown below. Clip is to be installed 2 inches in front access panel.

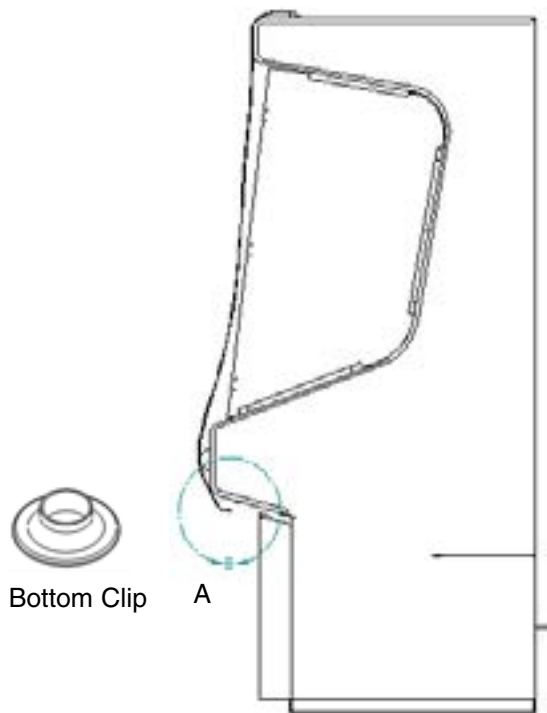
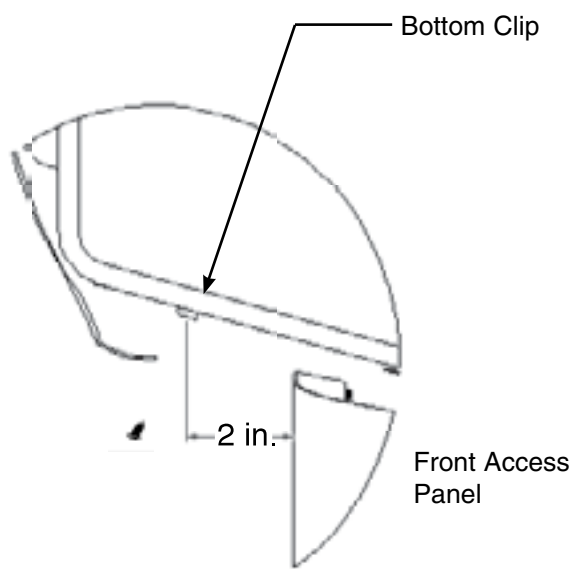

Hussmann Self-Contained Refrigeration Equipment Start Up Check List

Please note that failure to follow this start-up document may void your factory warranty

Step	Startup Activity	Check
1	Locate, read and maintain install/operation manual in a safe place for future reference.	<input type="checkbox"/>
2	Examine unit. Confirm there is NO damage or concealed damage.	<input type="checkbox"/>
3	Level the unit, side to side and front to rear.	<input type="checkbox"/>
4	Remove all shipping brackets/compressor straps/bolts etc.	<input type="checkbox"/>
5	Unit must be run on a dedicated electrical circuit without the use of an extension cord.	<input type="checkbox"/>
6	Ensure that the proper electrical requirements for the equipment are supplied.	<input type="checkbox"/>
7	Verify field electrical connections are tight.	<input type="checkbox"/>
8	Verify all electrical wiring is secured and clear of any sharp edges or hot lines.	<input type="checkbox"/>
9	Verify the condensate drain line is properly trapped and pitched.	<input type="checkbox"/>
10	Verify all required clearances on the sides and back of unit.	<input type="checkbox"/>
11	Verify there are no air disturbances external to the unit. Heat and air registers, fans, and doors etc.	<input type="checkbox"/>
Advise owner/operator that merchandiser must operate at temperature for 24 hrs prior to loading with product.		

Form HSCW01 Rev. 30MAY12 P/N 0525209_B

LEGAL DISCLAIMER:

Hussmann shall not be liable for any repair or replacements made without the written consent of Hussmann, or when the product is installed or operated in a manner contrary to the printed instructions covering installation and service which accompanied such product.

1-8 INSTALLATION

NOTES:

ELECTRICAL / REFRIGERATION

MERCHANDISER ELECTRICAL DATA

Refer to Appendix A of this manual or the merchandiser's serial plate for electrical information.

FIELD WIRING

Field wiring must be sized for component amperes stamped on the serial plate. Actual ampere draw may be less than specified.

ALWAYS CHECK THE SERIAL PLATE FOR COMPONENT AMPERES

ELECTRICAL CONNECTIONS

All wiring must be in compliance with NEC and local codes. All electrical connections *for GSVM-5272 self-contained* are to be made in the electrical *Handy Box* located behind the removable base panel at the left end of the merchandiser when facing the discharge air honeycomb. GSVM-4060 and GSVM-4072 is provided with a power cord.

POWER SWITCH

The main electrical power switch is located behind the front louvered access panel. The power switch must be turned OFF before servicing the merchandiser.

WARNING

— LOCK OUT / TAG OUT —

To avoid serious injury or death from electrical shock, always disconnect the electrical power at the main disconnect when servicing or replacing any electrical component. This includes, but is not limited to, such items as doors, lights, fans, heaters, and thermostats.

ELECTRICAL OUTLET:

Before the merchandiser is connected to any wall circuit, use a voltmeter to check that the outlet is at 100% of the rated voltage. The wall circuit must be dedicated for the merchandiser. Failure to do so voids the warranty. Do not use an extension cord. Never plug in more than one merchandiser per electrical circuit.

- Always use a dedicated circuit with the amperage stated on the unit.
- Plug into an outlet designed for the plug.
- Do not overload the circuit
- Do not use long or thin extension cords. Never use adapters.
- If in doubt, call an electrician.

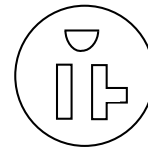

NEMA 5-20R
Receptacle
GSVM-4060
GSVM-4072

GSVM-4060 and GSVM-4072 has a factory-installed power cord that is attached at the electrical box.

WARNING

Risk of Electric Shock. If cord or plug becomes damaged, replace only with a cord and plug of the same type.

WARNING

Merchandiser must be grounded. Do not remove the power supply cord ground.

REFRIGERATION

(Self Contained Models)

Each self contained model is equipped with its own condensing unit and control panel located beneath the display area. The correct type of refrigerant will be stamped on each merchandiser's serial plate. The merchandiser refrigeration piping is leak tested. The unit is charged with refrigerant, and shipped from the factory with all service valves open.

GSVM models have a refrigeration system that uses a hermetic compressor. GSVM-4060 and GSVM-4072 systems use a capillary tube for refrigerant control. The capillary tube is soldered to the suction line pull-out coil for proper heat exchange. **If the capillary should become plugged or damaged, it is best to replace the heat exchanger.**

GSVM-5272 employs a bleed port type expansion valve for proper refrigerant control. Read the merchandiser's serial plate for the appropriate refrigerant type and weight.

WATER OUTLET AND WATER SEAL

GSVM models 4072 and 5272 require a floor drain. The condensate water outlet is located in the center of the merchandiser. The outlet has a factory-installed external water seal.

For self contained models like GSVM-4060, this water seal drains into an electric condensate pan located beneath the merchandiser. The pan uses a thermistor that senses water in the pan, adjusting the amount of heat required to evaporate the water. **Ensure the drain hose is properly trapped, and the drain area is not clogged.**

NOTE: All lower base panels must be in place when the refrigerator is operating. If not, airflow from the condenser will be directed over the evaporator pan and defrost water in the pan may overflow.

OPTIONAL ELECTRIC CONDENSATE PAN

An optional high-humidity condensate pan kit requires a dedicated 15 Amp circuit - 120V (GSVM-4072 and GSVM-5272).

**Safe-III™
TEMPERATURE AND DEFROST
CONTROLLER**

SAFE-NET III™ USER INSTRUCTIONS

Your refrigerated case uses a Hussmann Safe-NET™ III temperature and defrost controller to precisely maintain the temperature and prevent frost buildup on the cooling coil. LEDs indicate when the compressor or refrigeration is on, when the case is in a defrost cycle, if the temperature is outside the desired range, or if there is a sensor failure.

An adjustment knob allows the temperature to be set within the configured range and can power off the controller and compressor. Your controller has been custom-configured to provide the best temperature and defrost control for your chilled or frozen food.

The front of the controller has an adjustment knob and status LEDs. The back of the controller has connections for sensors and switched equipment.

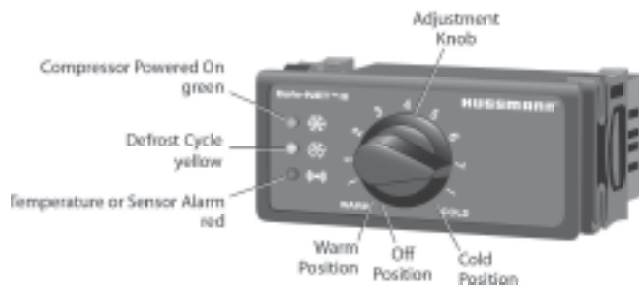

The Safe-NET III controller includes the following features and connections.

- Adjustment knob:
Adjusts the temperature setpoint.
Turn adjustment knob to OFF to turn off refrigeration system. Unplug merchandiser from power before servicing the unit.

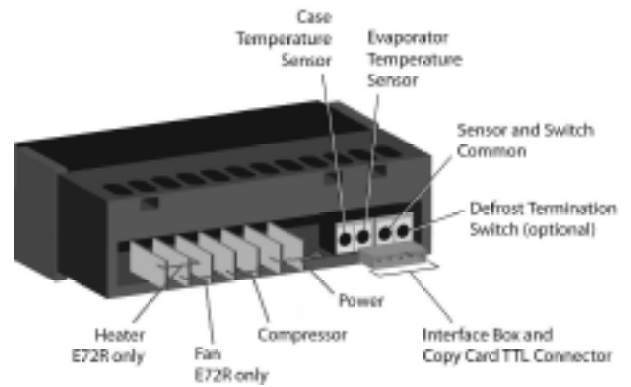

- Controller LEDs:
 - ❄️ Compressor Powered On LED (green):
Lights while the compressor is running or the refrigeration valve is open.
 - ❄️ Defrost Cycle LED (yellow):
Lights while the refrigeration coil is defrosting.
 - 🔊 Temperature or Sensor Alarm (red):
Lights if the temperature is too warm or too cold. Flashes if a sensor fails.

- Rear connections:
 - Case temperature sensor:
 - Typically senses the temperature of the air in the case.
Used by the controller to determine when to power on or power off the compressor or refrigeration.
 - Evaporator temperature sensor:
 - Senses the temperature of the refrigeration coil.
Terminates a defrost cycle when refrigeration coil ice melts.
 - Compressor or refrigeration relay:
 - Switches on the compressor or refrigeration valve for cooling.
 - Defrost / reversing condenser switch
 - Switches on the defrost or reversing condenser fan motor - when used with the condenser fan motor option.

DISPLAY

The display includes three red LEDs and two digits for temperature, defrost status, and error codes.

! WARNING

The optional evaporator fan remains ON when the adjustment knob is in the OFF position.

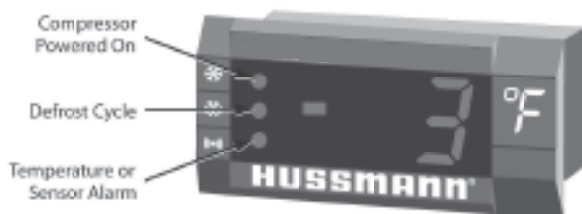

START-UP

! WARNING

The OFF Position does not disconnect line voltage to the case, refrigeration unit, fan, or heater.

1. Plug in the merchandiser.

NOTE: The 65°C Version Controller includes a **Parameter Code Number**. This number is **51** and indicates what program has been loaded into the controller. When the Controller is first powered up or is turned off and then back on a 2 digit Parameter Code Number will display for 3 seconds. Then the Self Check will Start.

2. Wait for the self check to complete. During the self check, each LED flashes for one second, then all LEDs turn on for two seconds. If the LEDs do not flash, make sure the adjustment knob is not in the Off position.
 - After the self check, all LEDs turn off until the compressor starts. **There may be a delay before the compressor starts.** If the red Temperature or Sensor Alarm LED stays on after the self check.
 - The green Compressor Powered On LED turns on when the compressor starts.

NOTE: Do NOT load product until AFTER merchandiser operates for 24 hours and reaches desired operating temperature. Behavior matches the LEDs on the controller.

! WARNING

Product will be degraded and may spoil if allowed to sit in a non-refrigerated area.

SEQUENCE OF OPERATION
GSVM

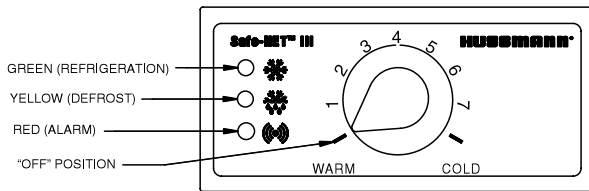
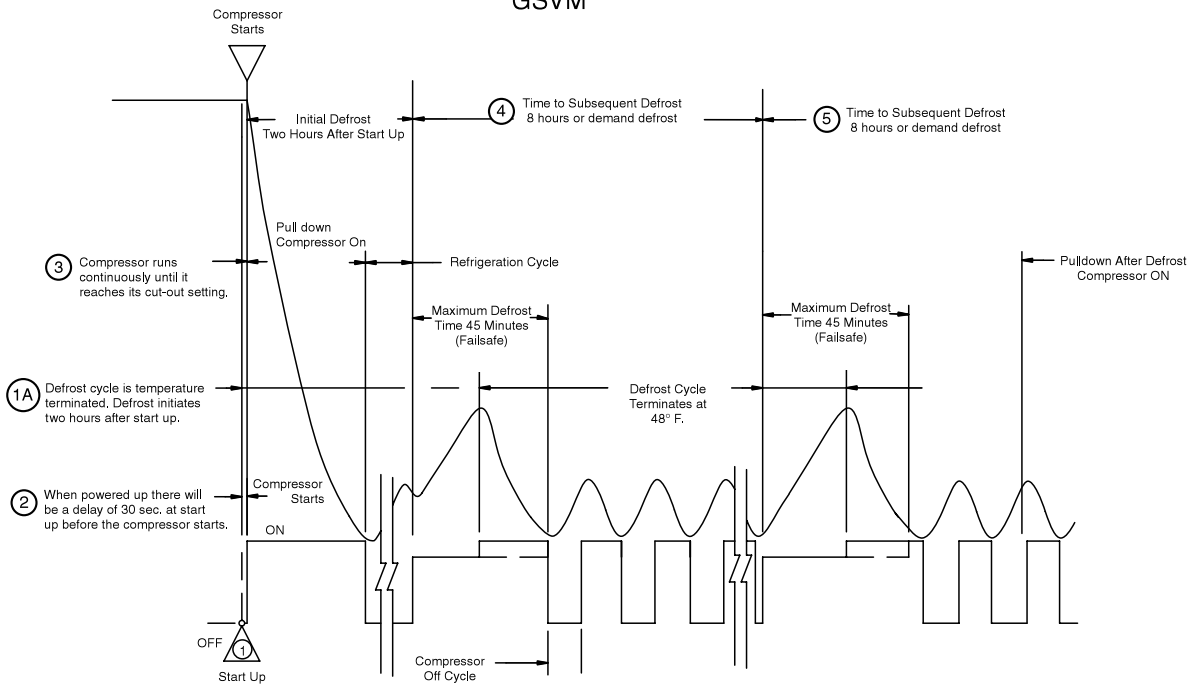

Safe-Net III Controller

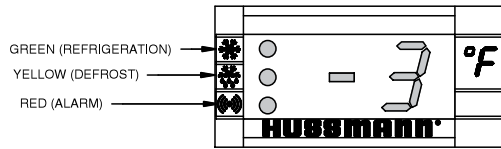

DISPLAY

1. Apply power to the merchandiser. Wait for the self check to complete. During the self check, each LED flashes for one second and then all LEDs turn on for two seconds. If the LEDs do not flash, make sure the adjustment knob is not in the “OFF” position.
- 1A. The merchandiser temperature displays at startup. The initial defrost starts two hours later. The display will show the temperature at the start of defrost. This reading will remain displayed during defrost and until it times out, even though the refrigeration mode has been initiated. (The green LED will be lit.)
2. The compressor will start after a 1-minute delay once power is applied.
3. The compressor will continue to run until it reaches its cut-out temperature (Pulldown).
4. The refrigeration cycle will continue for the next subsequent scheduled (8-hours) or demand defrost. The digital display will display the temperature reading for 10 minutes after defrost.
5. The above process will repeat (steps 3 and 4) until the power is interrupted.
6. If power stops, the process will start over at step 1, and the time to subsequent defrost will reset.

ALARMS AND CODES

FLASHING TEMPERATURE OR SENSOR ALARM LED, E1 OR E2

If the Temperature or Sensor Alarm LED (red) on the controller and display is flashing, a temperature sensor has failed. The display shows E1 if the case sensor has failed or E2 if the evaporator sensor has failed.

If the merchandiser sensor fails, refrigeration will run continuously. Turn off, or repeat a duty cycle of a few minutes on and a few minutes off.



DEFROST TERMINATION SWITCH

Merchandisers may use a defrost termination switch, instead of an evaporator sensor to terminate a defrost cycle. The defrost termination switch is temperature activated and senses the completion of defrost.

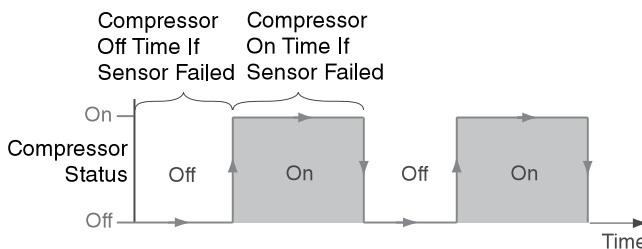

MANUAL DEFROST

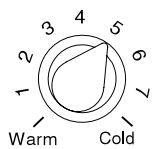

1. Note location of knob setting

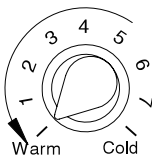

2. Rotate knob fully counterclockwise until it stops (full warm - "OFF" position)

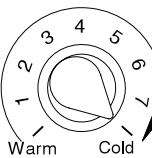

3. After 10 seconds, but before 20 seconds, rotate knob fully clockwise until it stops (full cold position)

Note:
This procedure initiates a manual or forced defrost.

IMPORTANT: Return the control knob to its original setting (Step 1) once the manual defrost has been initiated.

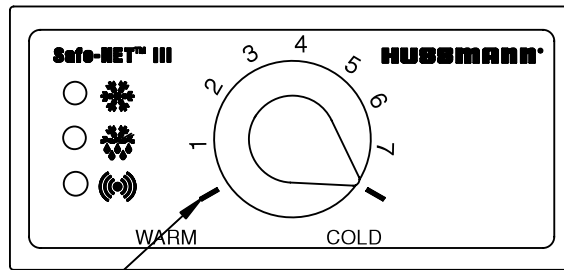

"OFF" Position — Safe-NET III Control Set at Full Cold Position

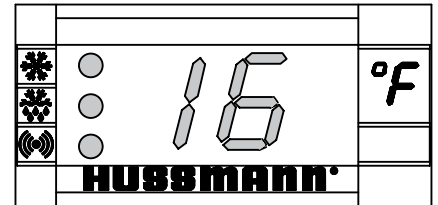

Display - at Full Cold Model GSVM

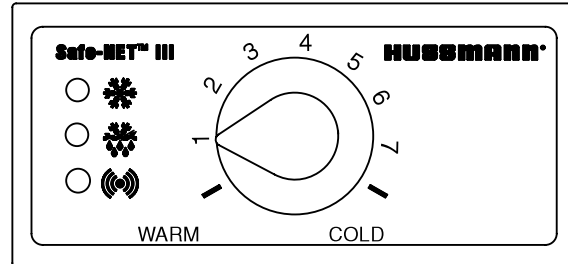

Safe-NET III Control # 1 Position

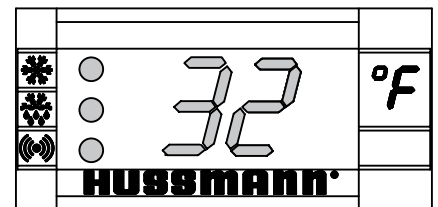

Display - at #1 Position Model GSVM

TEMPERATURE ADJUSTMENT

1. Rotate the adjustment knob counter clockwise for a warmer setpoint or clockwise for a colder setpoint.
2. While adjusting the temperature, the display shows the setpoint (cut out value). A few seconds after the temperature is set, the controller reverts to the sensed temperature in the merchandiser.
3. To verify merchandiser settings, turn the dial to warm and cold as shown above. Output readings should be within one degree of the temperatures shown above.

Typical Sensor to Control Configuration

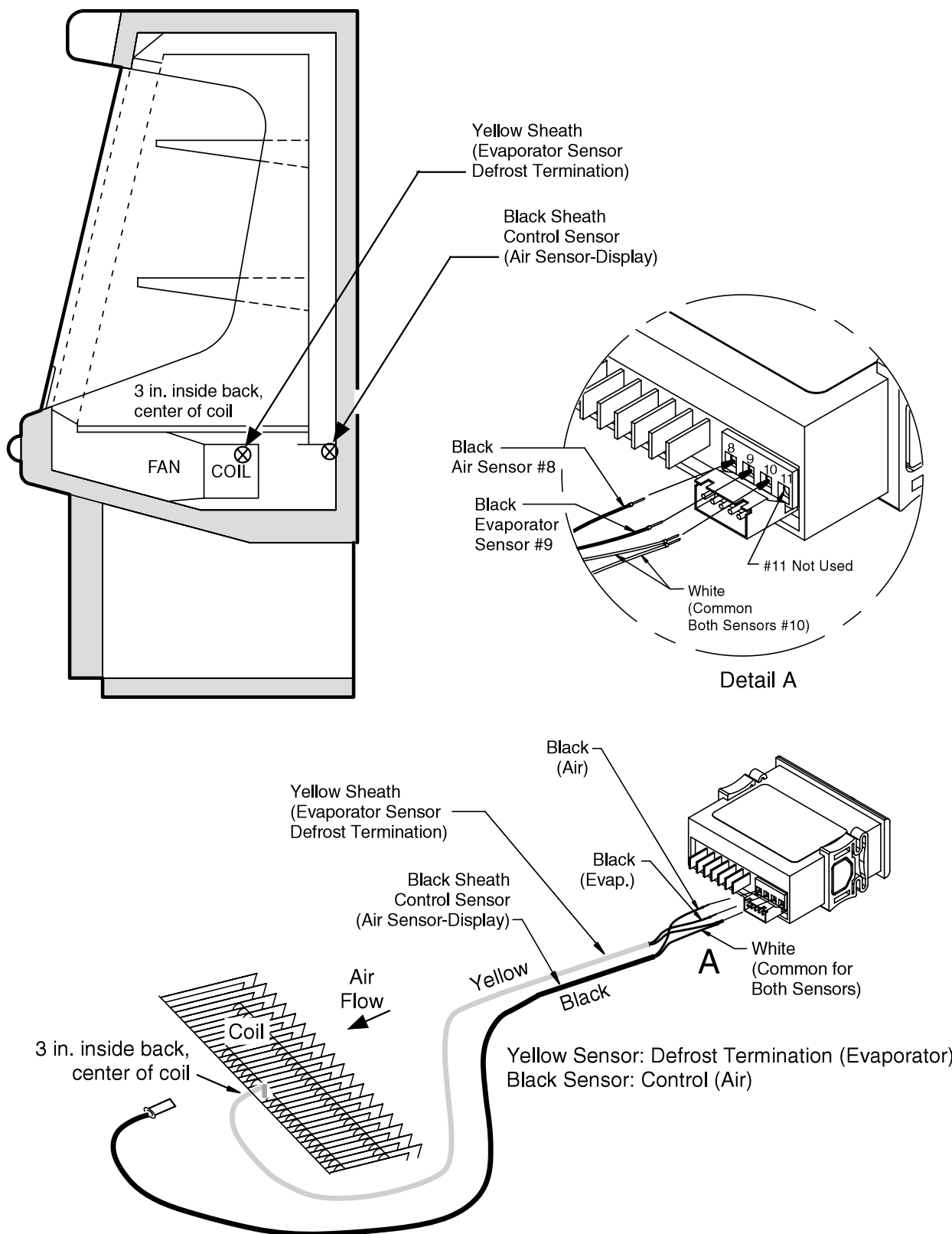

START UP / OPERATION

START UP

Follow the electromechanical controls start up procedures as detailed in Section 2 of this manual.

Each self contained merchandiser has its own evaporator coil. Model GSVM-5272 has an expansion valve (TEV). The TEV has been factory set at design conditions to provide the recommended performance. GSVM-4060 and GSVM-4072 have capillary tubes.

- Check the interior cabinet thoroughly for loose nuts, bolts and electrical connections.
- Inspect the refrigeration lines for visible damage or chafing.
- Replace electrical box cover and access panel.
- Turn on the electrical power, power switch and start the merchandiser. The merchandiser must pull down in temperature.

Allow merchandiser 24 hours to operate before loading product.

TEV Adjustment (GSVM-5272 only)

Expansion valves may be adjusted to fully feed the evaporator. Before attempting to adjust valves, make sure the evaporator is clear or only lightly covered with frost, and the merchandiser is within 10°F of its expected operating temperature. Adjust the valve as Follows:

- Attach a probe to the suction line near the expansion valve bulb.
- Obtain a pressure reading from the factory installed Schraeder valve. Convert the pressure reading to a saturated temperature for the refrigerant.

Temperature (b) minus Temperature (a) is the superheat. The valve should be adjusted so that the greatest difference between the two temperatures is 3° F (-16° C) to 5° F (-15° C).

Make adjustments of no more than 1/2 turn of the valve stem at a time and wait for at least 15 minutes before rechecking the probe temperature and making further adjustments.

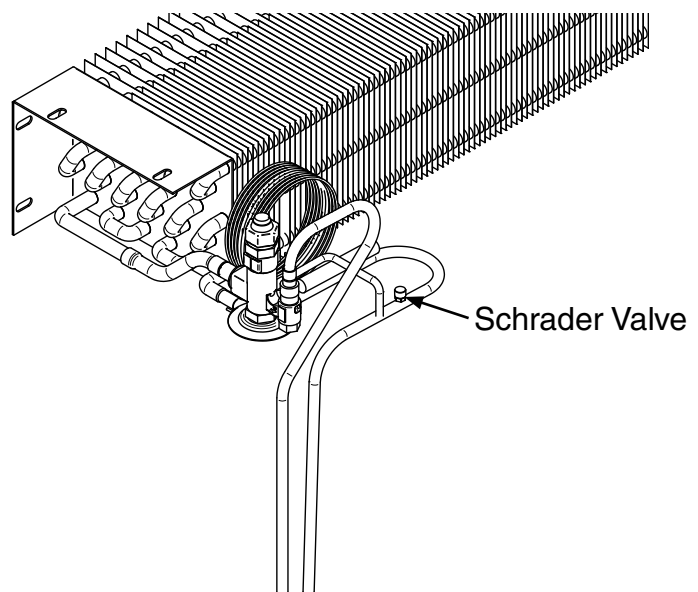

CONTROLS and ADJUSTMENTS

Refrigeration Controls			Defrost Controls			
Model	Product Application	Discharge Air Temperature	Defrost Frequency (per day)	Type of Defrost	Temp. Termination	Failsafe Time (Minutes)
GVSM-4060 Self Contained	Medium Temp. (Dairy, Deli)	30°-35° F	3	Off Time	48°F	45
GVSM-4072 Self Contained	Medium Temp. (Dairy, Deli)	30°-35° F	3	Off Time	48°F	45
GVSM-5272 Self Contained	Medium Temp. (Dairy, Deli)	30°-35° F	3	Off Time	48°F	45

1. The T-stat controller controls refrigeration temperature. This is factory installed in the control panel. Adjust this control knob to maintain the discharge air temperature shown. Measure discharge air temperatures at the center of the discharge honeycomb.

Defrosts are time initiated and time terminated for self contained. The defrost setting is factory set as shown above.

LOAD LIMITS

Each merchandiser has a load limit decal. Shelf life of perishables will be short if load limit is violated.

AT NO TIME SHOULD MERCHANDISERS BE STOCKED BEYOND THE LOAD LIMITS INDICATED.

DO NOT BLOCK AIR LOUVERS.



STOCKING

Product should NOT be placed inside the merchandisers until merchandisers are at proper operating temperature.

Allow merchandiser 24 hours to operate before loading product.

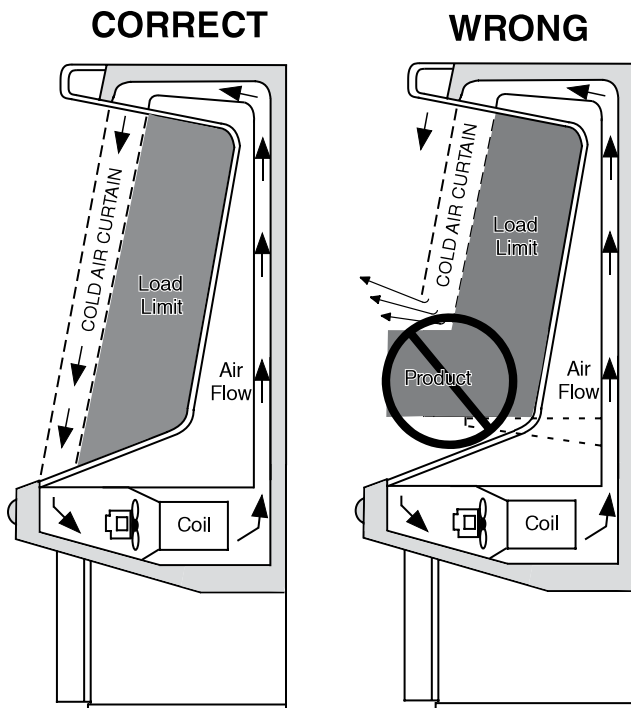

Do not stock product past shelves

! WARNING
Product will be degraded and may spoil if allowed to sit in a non-refrigerated area.

Proper rotation of product during stocking is necessary to prevent product loss. Always bring the oldest product to the front and set the newest to the back.

AIR DISCHARGE AND RETURN FLUES MUST REMAIN OPEN AND FREE OF OBSTRUCTION AT ALL TIMES to provide proper refrigeration and air curtain performance. Do not allow product, packages, signs, etc. to block these grilles. Do not use non-approved shelving, baskets, display racks, or any accessory that could hamper air curtain performance.

Do not allow product to be placed outside of the designated load limits in the illustration at left. Air flows through the back wall, over the product on the shelves, across the face of the product (air curtain), and into the return air grille.

SOLAR THERMOMETER

GSVM models have solar thermometers. The thermometer is located at the top, front center of the merchandiser's cabinet interior.

Temperature is displayed in Fahrenheit degrees as a standard option. Celsius is also an available option. The thermometer may be replaced if it becomes damaged.

To replace: remove the two screws securing the thermometer to its mounting bracket. Remove the sensing element from the clip, and install the new thermometer in reverse order.

SHELF MAXIMUM WEIGHT LIMITS

Husmann merchandiser shelves are designed to support the maximum weight load limits as indicated in the table below.

Exceeding these maximum weight load limits may cause damage to the shelf or shelves, damage to the merchandiser, damage to store products, and potentially create a hazardous condition for customers and staff. Exceeding the indicated maximum weight load limits constitutes misuse as described in the Husmann Limited Warranty.

GSVM-4060 has two standard shelves for product display. The 13 in. shelf should be positioned above the 15 in. shelf. Models GSVM-5272 and GSVM-4072 have an additional standard 13 in. shelf that is also to be positioned above the 15 in. shelf.

Maximum Shelf Weight Limits

	¹ Flat	17° Tilt	30° Tilt
Bottom Sheet Metal Area	250 lb (113.4 kg)	N/A	N/A
Standard 13 in. (330 mm) Shelf	250 lb (113.4 kg)	250 lb (113.4 kg)	75 lb (34 kg)
Standard 15 in. Shelf w/ optional 6° adapters	125 lb (56.7 kg)	N/A	N/A
Optional Wire Baskets	200 lb (90.7 kg)	100 lb (35.4 kg)	30 lb (13.6 kg)

¹ Shelf load limits at 0° tilt

MAINTENANCE

CARE AND CLEANING

Long life and satisfactory performance of any equipment is dependent upon the care it receives. To ensure long life, proper sanitation and minimum maintenance costs, these merchandisers should be thoroughly cleaned, all debris removed and the interiors washed down, weekly.

Exterior Surfaces

The exterior surfaces must be cleaned with a mild detergent and warm water to protect and maintain their attractive finish. **NEVER USE ABRASIVE CLEANSERS OR SCOURING PADS.**

Interior Surfaces

The interior surfaces may be cleaned with most domestic detergents, ammonia based cleaners and sanitizing solutions with no harm to the surface. Self contained models empty into a limited capacity evaporation pan, which will overflow if excess water is used in cleaning.

Do NOT Use:

- Abrasive cleansers and scouring pads, as these will mar the finish.
- Coarse paper towels on coated glass.
- Ammonia-based cleaners on acrylic parts.
- Solvent, oil or acidic based cleaners on any interior surfaces.
- Do not use high pressure water hoses.

WARNING

Product will be degraded and may spoil if allowed to sit in a non-refrigerated area.

Do:

- Disconnect electrical power before cleaning.**
- Remove the product and all loose debris to avoid clogging the waste outlet.
- Store product in a refrigerated area such as a cooler. Remove only as much product as can be taken to the cooler in a timely manner.
- Thoroughly clean all surfaces with soap and hot water. **DO NOT USE STEAM OR HIGH WATER PRESSURE HOSES TO WASH THE INTERIOR. THESE WILL DESTROY THE MERCHANDISERS' SEALING CAUSING LEAKS AND POOR PERFORMANCE.**
- Lift hinged fan plenum for cleaning. Hook chain in rear panel to secure plenum during cleaning. **BE SURE TO REPOSITION THE FAN PLENUM AFTER CLEANING MERCHANDISER.**
- Take care to minimize direct contact between fan motors and cleaning or rinse water.
- Do NOT flood merchandiser with water. **NEVER INTRODUCE WATER FASTER THAN THE**

WARNING

Do NOT allow cleaning agent or cloth to contact food product.

WASTE OUTLET CAN REMOVE IT.

SELF CONTAINED MODELS EMPTY INTO AN EVAPORATION PAN THAT WILL OVERFLOW IF TOO MUCH WATER IS INTRODUCED DURING CLEANING.

- Allow merchandisers to dry before resuming operation.
- After cleaning is completed, turn on power to the merchandiser.



WARNING

— LOCK OUT / TAG OUT —

To avoid serious injury or death from electrical shock, always disconnect the electrical power at the main disconnect when servicing or replacing any electrical component. This includes, but is not limited to, such items as doors, lights, fans, heaters, and thermostats.

CLEANING DISCHARGE HONEYCOMB

Discharge air honeycombs should be cleaned every six months. Dirty honeycombs will cause merchandisers to perform poorly. The honeycombs may be cleaned with a vacuum cleaner. Soap and water may be used if all water is removed from the honeycombs cells before replacing. Be careful not to damage the honeycombs.

1. Using a flat object such as a screw driver, compress the honeycomb and remove it from its retainer.
2. Clean and dry the air honeycombs.
3. After cleaning, replace in reverse order. Damaged honeycombs must be replaced.



CAUTION

DO NOT FLOOD!

Use only enough water necessary to clean surface. Water must not drip down the case!

Never use ammonia based cleansers, abrasive cleansers, or scouring pads.

CLEANING STAINLESS STEEL SURFACES

Use non-abrasive cleaning materials, and always polish with grain of the steel. Use warm water or add a mild detergent to the water and apply with a cloth. Always wipe rails dry after wetting.

Use alkaline chlorinated or non-chlorine containing cleaners such as window cleaners and mild detergents. Do not use cleaners containing salts as this may cause pitting and rusting of the stainless steel finish. Do not use bleach.

CLEANING SOLAR THERMOMETER

GSVM models have solar thermometers. The thermometer is located at the top, front center of the merchandiser's cabinet interior.

To clean the thermometer:

1. Remove the two screws securing the thermometer to its mounting bracket. Remove the sensing element from the clip
2. Use non-abrasive cleaning materials and a mild detergent to clean thermometer.
3. Be sure to wipe the element clean of any residues.



CAUTION

Do NOT use HOT water on Cold glass Surfaces. This can cause the glass to shatter and could result in personal injury. Allow glass fronts, to warm before applying hot water.

CLEANING UNDER DISPLAY PAN

Remove all product from the merchandiser and place in cooler. Always disconnect electrical power before cleaning.

1. Remove the display pan
2. Use non-abrasive cleaning materials and a mild detergent to clean display pan.
3. Wipe down the insides of the merchandiser with a mild detergent, and replace display pan. Allow merchandiser to pull down in temperature before loading product.

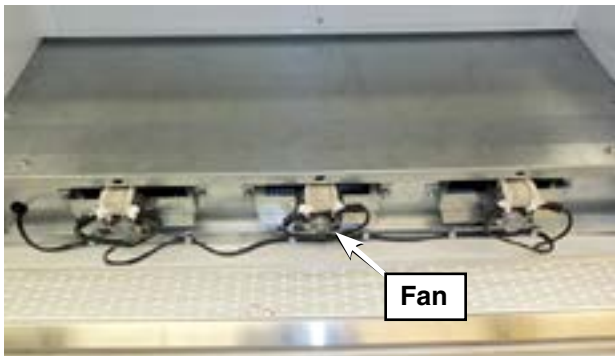

Merchandiser with display pan removed



**PRECAUTION
CLEANING PRECAUTIONS**

When Cleaning:

- Do not use high pressure water hoses
- Do not introduce water faster than waste outlet can drain
- NEVER INTRODUCE WATER ON SELF CONTAINED UNIT WITH AN EVAPORATION PAN
- NEVER USE A CLEANING OR SANITIZING SOLUTION THAT HAS OIL BASE (these will dissolve the butyl sealants) or an AMMONIA BASE (this will corrode the copper components of the merchandiser)
- TO PRESERVE THE ATTRACTIVE FINISH:
- Use a water and a mild detergent for the exterior only
- Do NOT use a chlorinated cleaner on any surface
- Do NOT use abrasives or steel wool scouring pads (these will mar the finish)

CLEANING EVAPORATION PAN

(GSVM-4060 STANDARD)

(GSVM-4072/5272-OPTIONAL)

The condensate water outlet for self contained models empties into a limited capacity evaporation pan.

Debris or dirt accumulation inside the condensate evaporation pan or on the heater coil will reduce the pan’s evaporation capacity and cause premature heater failure. The evaporation pan waste water will overflow and spill onto the floor if the heater is not properly operating.

Remove accumulated debris from the evaporation pan. Wipe down heater coil with a cloth and warm water. Be sure to remove any dirt, debris or liquids from the heater coil.

Water introduced during cleaning will cause the evaporation pan to overflow.

! WARNING

**Evaporation Pan is Hot!
and poses risk of bodily injury – Always
Wear gloves and protective eye wear when
servicing. Turn off evaporation pan heater,
and allow pan to cool.**

! WARNING

**SHUT FANS OFF DURING
CLEANING PROCESS.**

CLEANING COILS

Condenser coils should be cleaned at least once per month. Additional cleaning may be needed depending on the operational environment. A dirty condenser blocks normal airflow through the coils.

Airflow blockage increases energy consumption and reduces the merchandiser's ability to maintain operating temperature.

To clean the coils, use a vacuum cleaner with a wand attachment and a soft (non-metallic) brush to remove dirt and debris. Do not bend coil fins. Always wear gloves and protective eye wear when cleaning near sharp coil fins and dust particles.



NEVER USE SHARP OBJECTS AROUND COILS. Use a soft brush or vacuum brush to clean debris from coils. *Do not puncture coils!* Do not bend fins. Contact an authorized service technician if a coil is punctured, cracked, or otherwise damaged.

ICE in or on the coil indicates the refrigeration and defrost cycle is not operating properly. Contact an authorized service technician to determine the cause of icing, and to make adjustments as necessary. To maintain product integrity, move all product to a cooler until the unit has returned to normal operating temperatures.

MAINTAINING FLUORESCENT LAMPS

Fluorescent lamps should not be allowed to run to failure. If a re-lamp schedule is not in place, the tubes should be inspected for signs of degradation (blackened ends). Degraded or failed tubes should be replaced.

Allowing severely degraded lamps to operate may cause a ballast failure or could expose the lamp holder to excessive heat. Replacing degraded bulbs is more cost effective than replacing ballast and lamp-holders.

Traditional re-lamp programs are 18-to-24 month intervals. In the absence of a re-lamp program, a yearly inspection of the lighting system is recommended.

1. Inspect all lamp sockets and plug-receptacle connections for signs of arching. Replace any component that shows signs of arching.
2. Make sure all unused receptacles have their close-off covers securely installed.
3. Make sure proper cleaning procedures are followed. Lights and fans **MUST** be turned off when a case is cleaned and **MUST** be allowed to dry before turning power back on.
4. Do not use a pressure nozzle to clean inside of case.

REMOVING SCRATCHES FROM BUMPER

Most scratches and dings can be removed using the following procedure.

1. Use steel wool to smooth out the surface area of the bumper.
2. Clean area.
3. Apply vinyl or car wax and polish surface for a smooth glossy finish.

Self-Contained Refrigeration Equipment Maintenance Check List

***** Warranty does not cover issues caused by improper installation or lack of basic preventative maintenance. *****	
Record starting date	
Store Name and Number	
Store Address	
Unit Model Number	
Unit Serial Number	
Contractor/Technician	

	Technician		Q1	Q2	Q3	Q4	Q1	Q2	Q3	Q4
	PM date									
PM activity-For visual inspection items, denote "ok or complete" in the column to the right when PM has been performed. For measured data requested, record data requested in the appropriate column to the right)	Quarterly	Semi-Annually								
Check in with store manager, record any complaints or issues they have with unit.	X									
Look unit over for any damage, vibrations or abnormal noise.	X									
Verify unit is level side to side and front to rear.	X									
Confirm refrigerant lines properly are secured and not touching or rubbing other lines, wires or frame work.	X									
Verify fan motors and motor mounts are tight.	X									
Confirm fan blade/s are tight and not rubbing or hitting.	X									
Make sure all electrical connections, factory and field, are tight.	X									
Verify electrical connections at lamps are they secure and dry.	X									
Check for and replace any frayed or chaffed wiring.	X									
Check all electrical wiring make sure it is secured and not on any sharp edges or hot lines.	X									
Check for air disturbances external to the unit. Heat and air registers, fans, and doors etc.	X									
Check for water leaks.	X									
Clean evaporator coil/s and fan blade/s. Do not use an acid base cleaner. Rinse off any cleaner residue.		X								
Clean discharge air honeycombs or grilles. Do not use an acid base cleaner. Rinse off any cleaner residue.		X								
Clean condenser coil/s and fan blade/s. Do not use an acid base Cleaner. Rinse off any cleaner residue.		X								
Clean condensate drain pan and drain line.		X								
Verify condensate drain lines are clear and functioning.		X								
Record voltage reading at unit with unit off?		X								
Verify condenser and evaporator fans are working.	X									
Record condenser air inlet temperature	X									
Record condenser air outlet temperature	X									
Is condenser air inlet or air exhaust restricted or recirculating?	X									
Verify there are no visual oil or refrigerant leaks.	X									
Record voltage reading with unit running.		X								
Record compressor amp draw.		X								
Record defrost heater voltage and amp draw.		X								
Record anti-sweat heater voltage and amp draw.		X								
Record case product temperature.	X									
Record unit discharge air temperature.	X									
Record unit return air temperature.	X									
Record ambient conditions around unit (wet Bulb temperature and dry bulb temperature).	X									
Check product loading, do not load beyond the units load limits.	X									
Verify clearances on sides/back of unit.	X									
Check unit controller for proper operation. See controller or 1/0 Manual for proper controller operation.		X								
Confirm door switches function.	X									
Verify unit doors and lids work and are sealed correctly.	X									
Verify that all the panels, shields and covers are in place.	X									

Technician Notes:

4-6 MAINTENANCE

NOTES:

SERVICE

REPLACING FAN MOTORS AND BLADES

Should it ever be necessary to service or replace the fan motors or blades be certain that the fan blades are reinstalled correctly. **THE BLADES MUST BE INSTALLED WITH RAISED EMBOSSED (PART NUMBER ON PLASTIC BLADES) POSITIONED AS INDICATED ON THE PARTS LIST.**

For access to these fans:

1. Remove product and place in a refrigerated area. Disconnect electrical power.
2. Remove bottom pan.
3. **Disconnect fan from wiring harness.**
4. If it is determined that fan motor needs to be replaced, remove fan motor brackets from the fan plenum as shown.
7. Replace fan motor and/or blades.
8. Install brackets to fan motor and motor bracket to the fan plenum.
9. Reconnect fan motor to wiring harness.
10. Turn on power.
11. Verify that motor is working and blade is turning in the correct direction.
12. Reinstall display pans. Bring merchandiser to operating temperature before restocking.

⚠ WARNING

— LOCK OUT / TAG OUT —

To avoid serious injury or death from electrical shock, always disconnect the electrical power at the main disconnect when servicing or replacing any electrical component. This includes, but is not limited to, such items as doors, lights, fans, heaters, and thermostats.

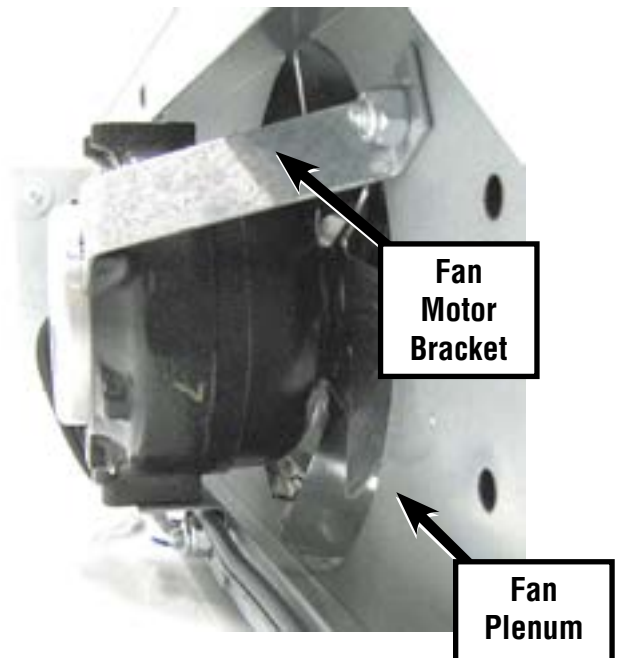

⚠ WARNING

Product will be degraded and may spoil if allowed to sit in a non-refrigerated area.

REPLACING FLUORESCENT LAMPS

Fluorescent lamps have a plastic shield. When the lamp is replaced, keep the lamp shield to install over the new lamp.

The switch under the display lamp cover operates both the display lamp and interior lamps.

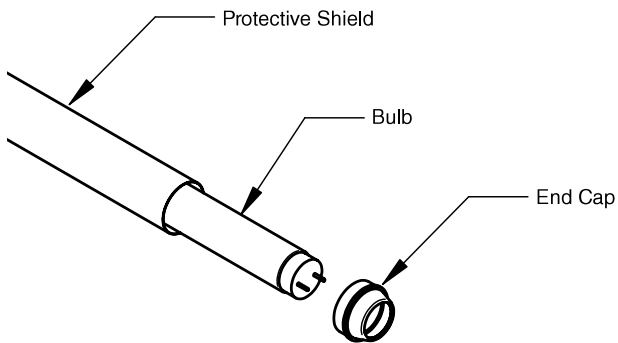

Remove Plastic Pins Attaching Display Lamp.

⚠ WARNING

— LOCK OUT / TAG OUT —

To avoid serious injury or death from electrical shock, always disconnect the electrical power at the main disconnect when servicing or replacing any electrical component. This includes, but is not limited to, such items as doors, lights, fans, heaters, and thermostats.

LED FIXTURE REPLACEMENT

For canopy LEDs, the protective shield is incorporated as part of the LED fixture. Rotate the LED fixture to release it from the lamp holder. Shelf LED fixtures are held in place by magnets. Pull the fixture down firmly to release disconnect cord from receptacle on the rear wall.

⚠ WARNING

Fluorescent lamps contain mercury vapor. Mercury exposure at high levels can harm the brain, heart, kidneys, lungs, and immune system of people of all ages. Do not break or puncture fluorescent lamps. Dispose of, or store, all fluorescent lamps in accordance with Federal (40 CFR 273), State, and local hazardous waste requirements. Refer to: <http://www.epa.gov/mercury/about.htm>

TROUBLESHOOTING GUIDE

PROBLEM	PROBABLE CAUSE	SOLUTION
Compressor will not start. (no noise)	<ol style="list-style-type: none"> 1. Power disconnected 2. Blown fuse or breaker 3. Defective or broken wiring 4. Defective overload 5. Defective temperature control 	<ol style="list-style-type: none"> 1. Check service cord or wiring connection 2. Replace fuse or reset breaker 3. Repair or replace 4. Replace 5. Replace
Compressor will not start; cuts out on overload.	<ol style="list-style-type: none"> 1. Low voltage 2. Defective compressor 3. Defective relay 4. Restriction (pinched cap tube) 5. Restriction (moisture) 6. Condenser blocked with dust and dirt 7. Defective condenser fan motor 	<ol style="list-style-type: none"> 1. Cabinet voltage must not be more than 5% below rating 2. Replace 3. Replace 4. Repair or replace 5. Leak check, replace drier evacuate and recharge 6. Clean condenser 7. Replace
Warm storage temperature	<ol style="list-style-type: none"> 1. Temperature control not set properly 2. Short or refrigerant 3. Cabinet location too warm 4. Refrigerant over-charge 5. Low voltage, compressor cycling on overload 	<ol style="list-style-type: none"> 1. Reset control. Rotate knob Clockwise 2. Leak check, replace drier evacuate and recharge 3. Move to cooler location or correct excessive heat source 4. Purge system, evacuate and recharge 5. Compressor voltage must not be more than 5% below rating
Compressor runs continuously; product too warm.	<ol style="list-style-type: none"> 1. Short of refrigerant 2. Inefficient compressor 3. Coil iced up 	<ol style="list-style-type: none"> 1. Leak check, replace drier, evacuate and recharge 2. Replace 3. Force manual defrost
Compressor runs continuously; product too cold	<ol style="list-style-type: none"> 1. Defective control 2. Control sensing element not in positive contact 3. Short on refrigerant 	<ol style="list-style-type: none"> 1. Replace 2. Assure proper contact 3. Leak check, replace drier evacuate and recharge

TROUBLESHOOTING LIGHT GUIDE

PROBLEM	SOLUTION
Lights won't start	<ol style="list-style-type: none"> 1. Check light switch 2. Check continuity to ballast / Power Supply 3. Check to see if bulbs are inserted properly in sockets 4. Check voltage
Lights flicker	<ol style="list-style-type: none"> 1. Allow lamps to warm up 2. Check lamp sleeve for cracks 3. Check sockets for moisture and proper contact 4. Bulb replacement may be necessary 5. Check voltage 6. New bulbs tend to flicker until used

GSVM ACCESSORIES

The following is a description of the various accessories available for the GSVM.

Caster Kit — Consists of 5 in. braking casters, which screw in to the standard threaded holes in the four corners under the cage occupied by the standard leg levelers. The kit will add 5 ⁵/₈ in. of height to the case.

Leg Kit — The legs also go into the same holes as the standard levelers, which will have to be removed. The legs are adjustable and will add 5 ⁵/₁₆ in. to the height of the case. The skirt kit requires the use of these legs.

Four-sided Skirt Kit — This is a four-sided skirt that encloses the open area under the merchandiser when the leg kit is used. The skirt kit clamps to the legs.

Night Cover — This is a clear, 5 mm thick, polyester shade cover that covers the face of the merchandiser. It will fasten to the top of the merchandiser and be drawn to a snap fastener in the area above the front bumper. The cover, although loose fitting on the ends, will conserve energy during periods when the store is not open. The cover is standard on the GSVM-5272.

Wrap-Around Bumper Kit — This bumper replaces the standard front bumper and wraps around both sides of the merchandiser at the standard height of 22 inches to the centerline of the 2 ¹/₄ in. wide bumper.

Colored Accent Panel — This panel can be (a.) the top front panel over the product, (b.) the panel behind the bumper, or (c.) the access panel below the bumper panel, or any combination of these.

Shelf end Trim Kit — Consists of four painted steel ends for the standard 13 in. and 15 in. shelves. This trim conceals and protects the exposed ends of the shelves. The trim kit attaches by two snap fasteners supplied with each trim piece for the GSVM-4060 model.

High Humidity Condensate Pan — (For GSVM-4072 & 5272) This is a 1,000 watt, 9 Amp. pan with a 6 ft - 9 in. 115V power cord attached. A dedicated circuit is required.

Shelf Upslope Tilt Adapter Kit — This kit consists of four zinc coated wire adapters to increase the two standard shelves, upslope from 1 1/2° to 6°.

Price Tag Molding Kit — This kit consists of aluminum price tag molding for the standard shelves. Price tag moulding will hold both 1 in. and 1.235 in. standard price tags. (Note that the standard shelves accept 1.235 in. tags.)

Wire Product Stop Kit — This kit consists of a 2 in. high chrome plated open wire stops for the standard shelf. This stop is mounted under tension and should not be confused with the wire front in the partition kit.

Wire Partition Kit — This is a free-standing wire system, which attaches to the standard shelves, and consists of a wire front, (different from the product stop) two wire sides and two partitions from the front to back, all chrome plated and 3 inches high.

Wire Cross Divider — This is a 3 inch high and 4 inch-long divider that could be ordered to be used with the wire partition kit above.

Wire Basket Kits — One kit is available to replace the top 13 in. shelf or shelves, another is available to replace the bottom 15 in. shelf. Each kit consists of a wire basket, two brackets, and two dividers, which could also be used as ends. These parts are zinc plated. The baskets have an 8 in. high back and a 4 in sloped front.

Wire Basket Dividers — These are additional dividers, which can be with the wire baskets kit to obtain additional partitioned areas in the baskets.

Additional Lighted Shelf — This consists of an additional 13 in. lighted shelf that can be positioned between the two standard shelves. It is the same construction as the top standard 13 in. shelf.

LED Lights — LED light fixtures replace fluorescent lights. This technology saves energy and extends component life.

Night Curtain — Night curtains cover the throat opening of the case and is installed on the case after normal business hours. Night curtains help reduce energy costs, allowing the refrigeration system to work less when the case is not in use. The night curtain for GSVM is standard for model 5272 and is an optional kit for models 4060 and 4072.

5-6 SERVICE

NOTES:

Parts List

MODELS		GSVM4060	GSVM4072	GSVM5272
Standard Parts				
Description	Part Number			
Evaporator Fan Motor	21S147	X	X	X
Evaporator Fan Blade	21S080	X	X	X
Evaporator Fan Motor Bracket	76218	X	X	X
Air Sensor (Black) 1500MM	0509122	X	X	X
Defrost Sensor (Yellow) 1500MM	0509123	X	X	X
Safe-Net III Controller 65C	0524119	X	X	X
Safe-Net III Display (F°) 65C	H159052	X	X	X
Safe-Net III Display Interface Cable	0509783	X	X	X
Safe-Net III Control Harness	0513058	X	X	X
Compressor Relay (T92P7A22-120)	0459304	X	X	X
Power Switch	03S286	X	X	X
Solar Thermometer	05S521	X	X	X
Assembly Lighted shelf Fluorescent 13" X 36	290631	X	X	
Assembly Lighted shelf Fluorescent 15" X 36	290632	X	X	
Assembly Lighted shelf Fluorescent 13" X 48	292131			X
Assembly Lighted shelf Fluorescent 15" X 48	292132			X
Shelf 13 X 36	22S2101	X	X	
Shelf 15 X 36	22S1932	X	X	
Shelf 13 X 48	22S2102			X
Shelf 15 X 48	22S244			X
Lamp Fluorescent (Shelf)	06S149	X	X	
Lamp Fluorescent (Canopy)	06S029	X	X	
Lamp Fluorescent (Shelf & Canopy)	06S010			X
Ballast Canopy Light	06S187	X	X	X
Ballast (lighted shelf)	06S042	X	X	
Ballast (lighted shelf)	06S016			X
Safety Shield Canopy light	06S07243	X	X	
Safety Shield Canopy & Shelf	06S0742			X
Safety Shield Shelf light	06S07417	X	X	
Starter Socket (Shelf Light)	06S024	X	X	X
Starter (Shelf Light) F-S2)	06S041	X	X	
Starter (Shelf Light) F-S4)	06S019			X
Lamp Holder (Canopy)	06S004	X	X	X
Lamp Holder (Shelf Light)	06S185	X	X	X
Light Switch (Canopy & Shelf)	03S176	X	X	X
Plug (3 prong (Lighted shelf)	19S691	X	X	X
Shelf Harness (3 shelf)	19S674	X	X	
Shelf Harness (4 shelf)	19S688			X
Evaporator Fan & Light Harness	19S6891	X		
Evaporator Fan & Light Harness	19S6892		X	X
Side Plexiglass Ends	29S892			X
Front Plexiglass	29S8961	X	X	
Front Plexiglass	29S8962			X
Leg Leveler	35S024	X	X	X
Black rubber Drain Hose (32")	18S063	X	X	X
Night Curtain	35S066			X
Front Bumper End Cap (Black)	18S2932	X	X	X
Honeycomb	0519007	X	X	
Honeycomb	29S6812			X
Power Cord NEMA 5-20P	19S63612	X	X	

Parts List

MODELS		GSVM4060	GSVM4072	GSVM5272
OPTIONAL LED Canopy & Shelf				
Description	Part Number			
LED Canopy Lamp	0515964	X	X	
LED Canopy Lamp	0515965			X
LED Shelf Lamp	0523752	X	X	
LED Shelf Lamp	0523755			X
LED Power Supply	0518898	X	X	X
LED Harness 4 plug	0501237	X	X	X
LED Harness Plug	0523768	X	X	X

Refrigeration				
Condensing Unit Assy	0522149	X	X	
Condensing Unit Assy	292122			X
Drier (C052-S)	17S362	X	X	
Drier (C082-S)	17S365			X
Pull out Coil assy	29216	X	X	
Pull out Coil assy	29435			X
Assembly Evaporator Coil	291211	X	X	
Assembly Evaporator Coil	292951			X
Cap Tube Assembly	29152	X	X	
TXV (Sporlan EGSE-1-C) Sweat	E205982			X
TEV (Sporlan FS-1-C-B10) Flare	17S506			X
Evaporator Coil	26S116	X	X	
Evaporator Coil	26S115			X
Accumulator	17S098	X	X	

Condensate Pan				
Electric Condensate Pan Assy (350W)	29254	X		
Condensate Pan (only)	29253	X		
Condensate Pan Heater (350w)	19S678	X		
Condensate Pan (1000w) Optional	1601835		X	X

Sheel Metal Replacement Parts Painted	All these part numbers below are painted assemblies			
Front Louvered Access Panel w/SNIII KO	291434	X	X	
Front Louvered Access Panel w/SNIII KO	291435			X
Bottom Display Shelf-White	290211	X	X	
Bottom Display Shelf-White	290212			X
Front LH Glass Brkt Assy (Metallic Silver)	294861	X	X	X
Front RH Glass Brkt Assy (Metallic Silver)	294862	X	X	X
Rear lower Panel-White	290001	X	X	

DOE 2012
Energy Efficiency
Compliant

Husmann refrigerated merchandisers configured for sale for use in the United States meet or surpass the requirements of the DOE 2012 energy efficiency standards.

GSVM

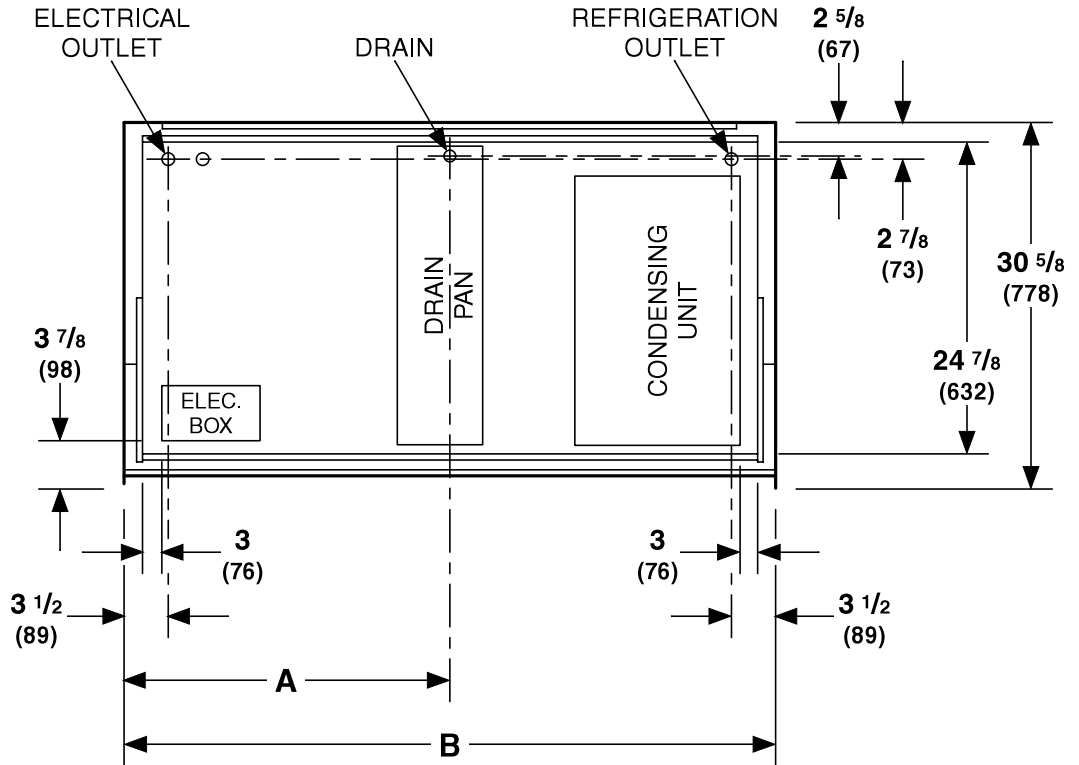

MODEL	"A"	"B"
GSVM 4072	20"	40"
GSVM 4060	26"	52"

General

	GSVM-4060	GSVM-5272
Case Length (<i>Note: Includes One Pair Ends</i>)	40 in. (1016 mm)	52 in. (1321)
Optional End Bumpers (<i>One Pair</i>)	2 in. (51 mm)	2 in. (51 mm)

Waste Outlet

LH end of case (<i>from outside of End Assembly</i>) to center of waste outlet	20 in. (508 mm)	26 in. (660 mm)
---	-----------------	-----------------

Dimensions shown as inches and (mm).

GSVM-4060

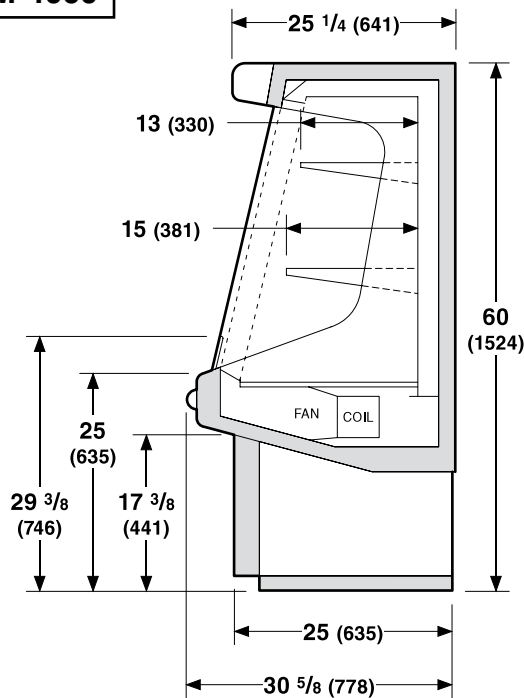

REFRIGERATION DATA

**GSVM-4060 GSVM-4072
GSVM-5272**

Thermostat

Setting CI/CO (°F)

	Position:	#1	#7
GSVM		36	36
		32	16

Condensing Unit (hp) 3/4 hp (All Models)

Condensing Unit

Capacity

GSVM-4060/4072	4410
GSVM-5272	4610
(Btu per hour at std. rating conditions)	

**GSVM-4072
GSVM-5272**

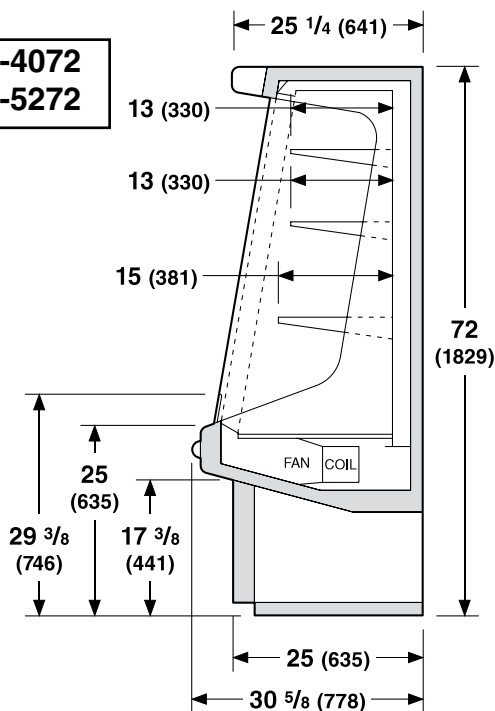

DEFROST DATA

Frequency (hour)

GSVM-4060/4072/5272	8
---------------------	---

OFFTIME

Failsafe (minutes)

GSVM-4060/4072/5272	45
---------------------	----

Defrost Termination

Temperature Terminated

PHYSICAL DATA

Refrigerant Charge

GSVM-4060 (R134a)	33 oz	0.936 kg
GSVM-4072 (R134a)	32 oz	0.907 kg
GSVM-5272 (R404a)	46.5 oz	1.318 kg

Note: This data is based on store temperature and humidity that does not exceed 75°F and 55% R.H. unless otherwise stated. Schedule defrost at night while lights are off.

Electrical Data

Note: These are rated values for individual components and should not be added together to determine total merchandiser electrical load.

	GSVM-4060/4072		GSVM-5272	
Number of Fans – 4W (open shell)	2		3	
	Amperes	Watts	Amperes	Watts
Evaporator Fans				
115V 60Hz Standard	0.8	8	1.2	12
Condensate Pan Heaters (115V)	3	350		
GSVM-4060 (only)				
Condensate Pan Heaters (115V)			9.0	1000
GSVM-4072/GSVM-5272				
Condensing Unit (115V, 1Ph, 60Hz) Standard				
GSVM-4060/4072				
Compressor LRA		78.0		
Compressor RLA		13.6		
GSVM-5272				
Compressor LRA		70.0		
Compressor RLA		15.0		

Product Data

GSVM-4060

*ARI Total Display Area*¹ (Sq Ft/Case) 11.04 ft² /case (1.086 m² /case)

GSVM-4072

*ARI Total Display Area*¹ (Sq Ft/Case) 16.65 ft² /case (1.546 m² /case)

GSVM-5272

*ARI Total Display Area*¹ (Sq Ft/Case) 18.47 ft² /case (1.878 m² /case)

¹ Computed using AHRI 1200 standard methodology:
Total Display Area, ft² [m²] / Unit of Length, ft [m]

	Nominal HP	Refrigerant Type	Volts	Run Amps	Nema Plugs	Fuse Amps	Hz / Ph
GSVM-4060	¾	R134a	115	16	5-20P	20	60/1
GSVM-4072	¾	R134a	115	15.5	5-20P	20	60/1
*GSVM-5272	¾	R134a	115	19.5	Hard Wired	25	60/1

*Requires field wiring.

Optional 1,000W Hi-Humidity Condensate Pan requires a dedicated 120V/15 Amp circuit

ESTIMATED SHIPPING WEIGHT ²

<i>Case</i>	<i>self contained</i>	<i>remote</i>	<i>End</i>
GSVM-4060	380 lb (172kg)	308 lb (140kg)	Included
GSVM-4072	425 lb (193kg)	353 lb (160kg)	Included
GSVM-5272	600lb (272kg)	520 lb (236kg)	Included

² Actual weights will vary according to optional kits included.

GSVM-4060

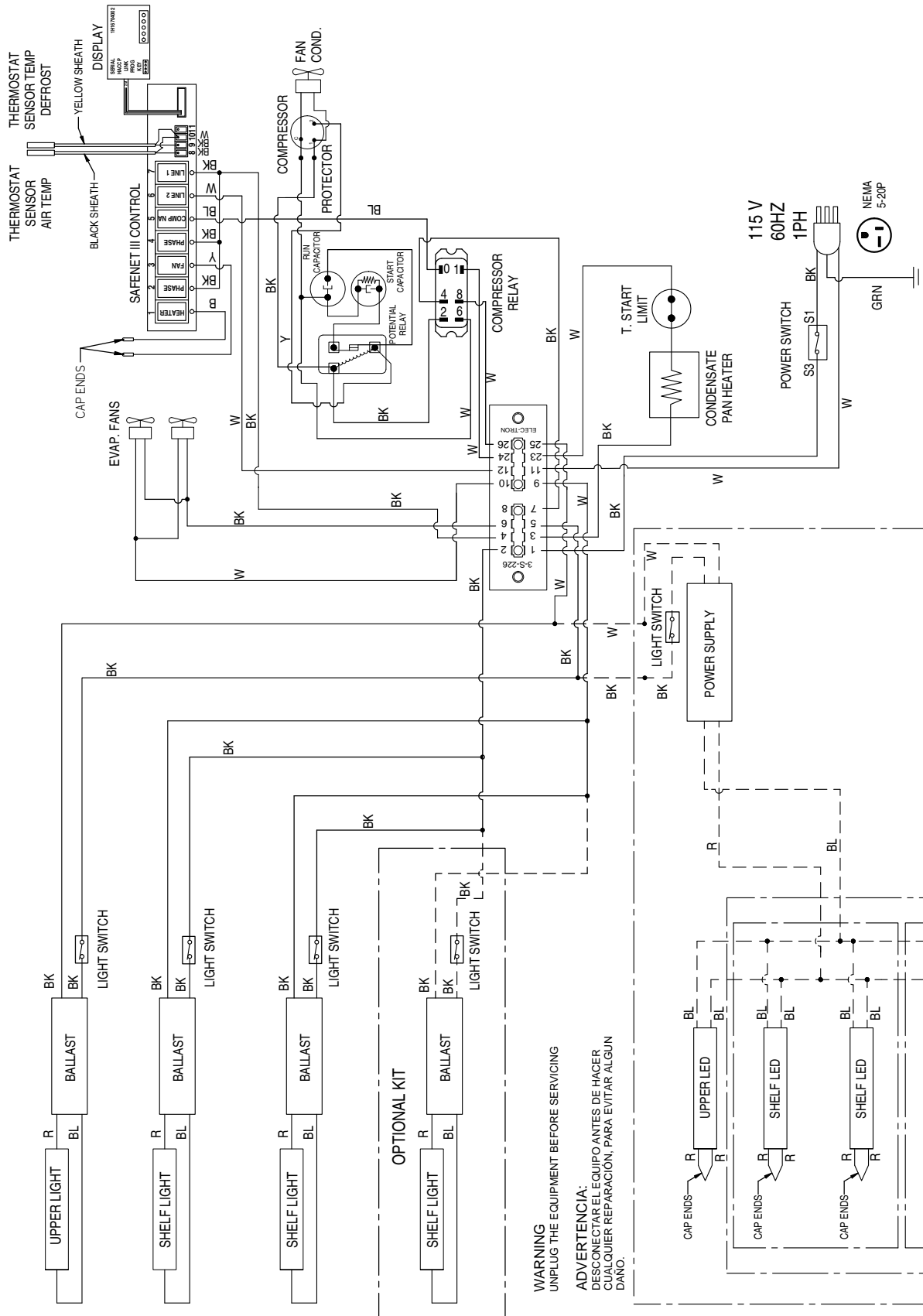

0523611_B

ELECTRIC SPECS
 MODEL GSVM4060
 VOLTAGE 115 V
 FREQUENCY 60 HZ

WARNING
 UNPLUG THE EQUIPMENT BEFORE SERVICING

ADVERTENCIA:
 DESCONECTAR EL EQUIPO ANTES DE HACER CUALQUIER REPARACIÓN. PARA EVITAR ALGUN DAÑO.

OPTIONAL LED LIGHT KITS

GSVM-4072

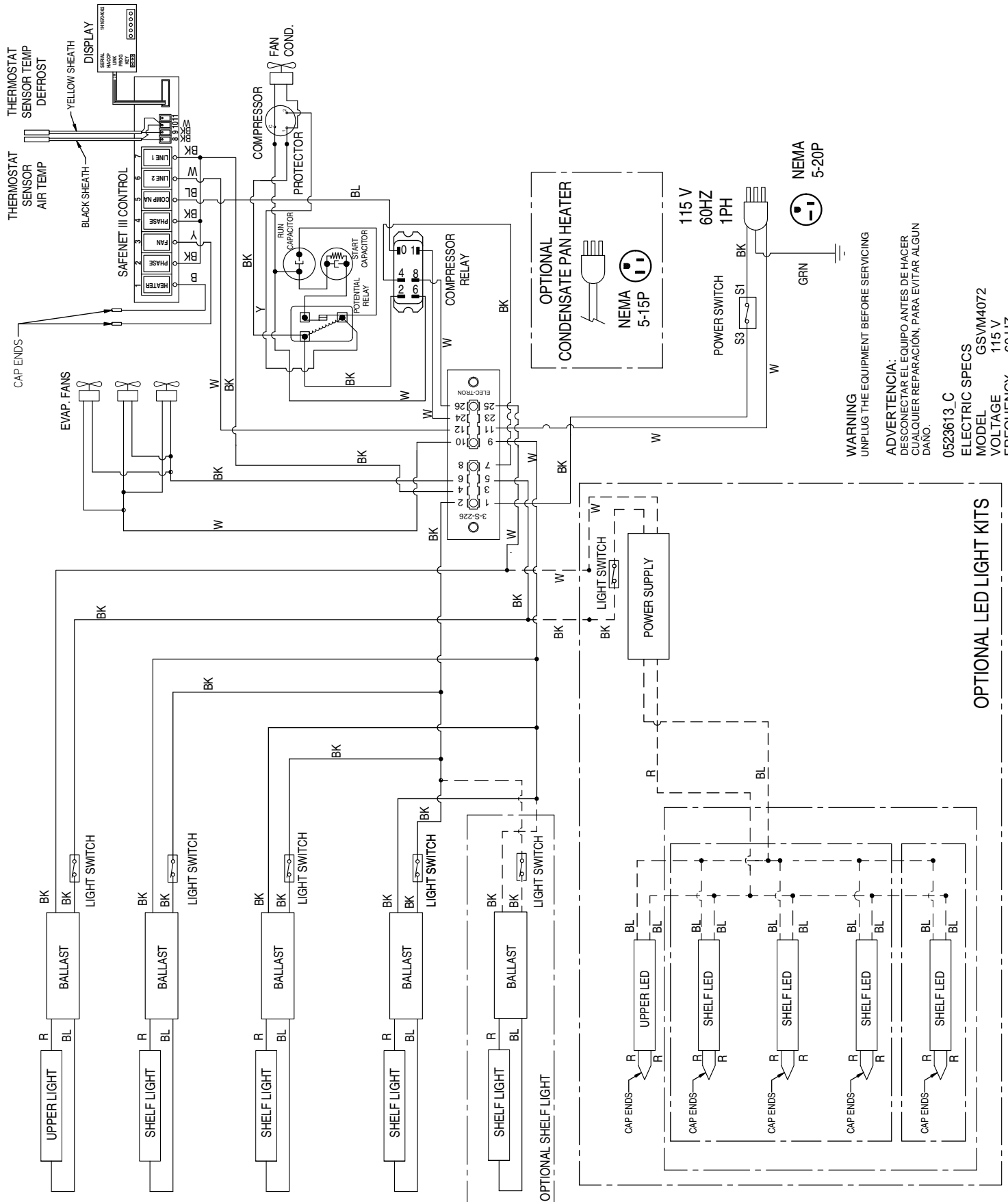

WARNING
UNPLUG THE EQUIPMENT BEFORE SERVICING

ADVERTENCIA:
DESCONECTAR EL EQUIPO ANTES DE HACER CUALQUIER REPARACIÓN PARA EVITAR ALGUN DAÑO.

0523613_C
ELECTRIC SPECS
MODEL GSVM4072
VOLTAGE 115 V
FREQUENCY 60 HZ

GSMV-5272

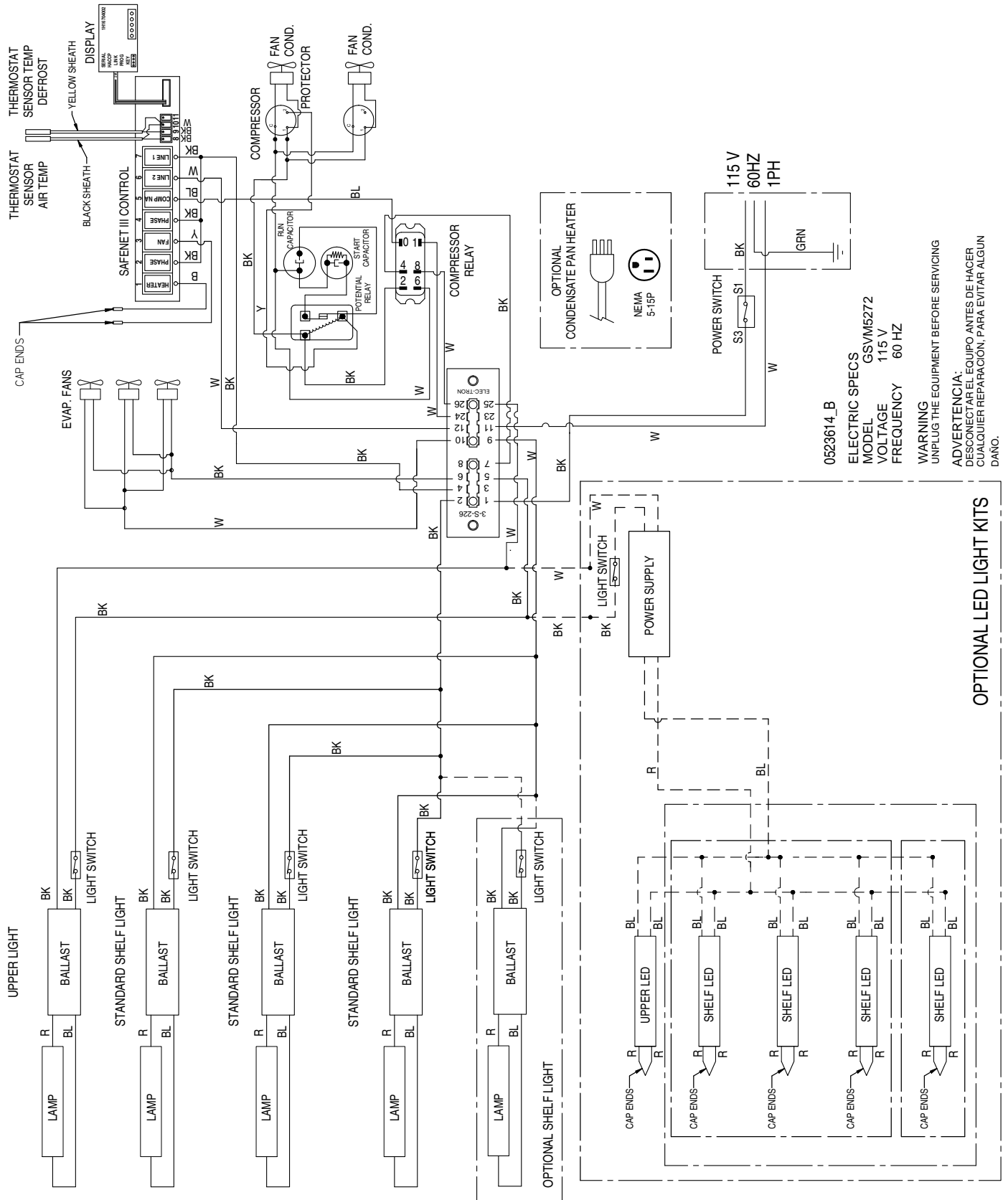

0523614_B

ELECTRIC SPECS
 MODEL GSMV5272
 VOLTAGE 115 V
 FREQUENCY 60 HZ

WARNING
 UNPLUG THE EQUIPMENT BEFORE SERVICING
 ADVERTENCIA:
 DESCONECTAR EL EQUIPO ANTES DE HACER
 CUALQUIER REPARACION, PARA EVITAR ALGUN
 DAÑO.



HUSSMANN[®]

**To obtain warranty information
or other support, contact your
Hussmann representative.
Please include the model and
serial number of the product.**

Hussmann Corporation, Corporate Headquarters: Bridgeton, Missouri, U.S.A. 63044-2483 01 October 2012