



SAFETY PRECAUTIONS

Be careful when working near glass doors. Basic safety precautions should be followed when installing or replacing shelves. Always wear appropriate personal protection equipment (PPE) including arm guards, protective eyewear, thick gloves that cover the wrists, and protective sleeves that cover the wrists to reduce injuries when working near glass.



ANSI Z535.5 DEFINITIONS

-  • **DANGER** – Indicate[s] a hazardous situation which, if not avoided, will result in death or serious injury.
-  • **WARNING** – Indicate[s] a hazardous situation which, if not avoided, could result in death or serious injury.
-  • **CAUTION** – Indicate[s] a hazardous situation which, if not avoided, could result in minor or moderate injury.
- **NOTICE** – *Not related to personal injury* – Indicates[s] situations, which if not avoided, could result in damage to equipment.

Installing shelves requires two or three persons. Always start inserting shelves in a bottom to top order. Make sure there is enough room to assemble.

 **WARNING**
Ensure shelving and each shelf is secured in place. Install shelving according to the installation instructions. Personal injury may occur if shelves are not properly secured.

 **WARNING**
Do not stand or climb on shelving unit. Always use more than one person when assembling.

Each shelf is 4ft across and 27 inches deep. Each shelf is to be positioned behind a pair of EcoVision doors.

There are two kit options available for the shelving:

A Center Kit and an End Kit.

End Shelf Kit should be assembled first. Shelf kits are to be installed left to right, when facing the inside of the cooler.

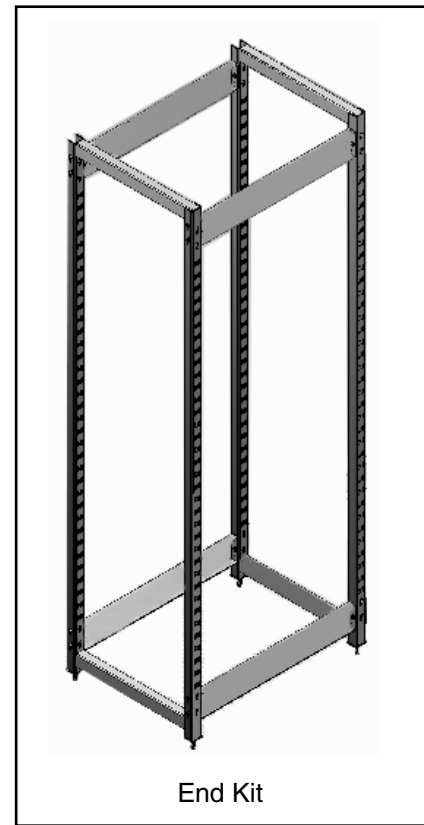
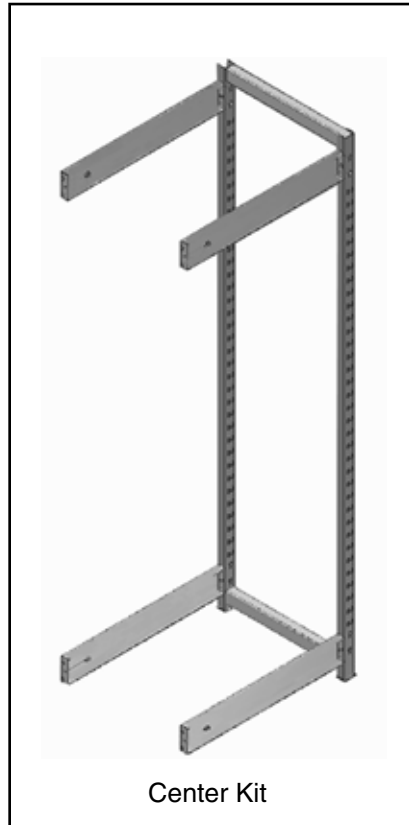

INSTALLATION

- 1 Add post levelers by screwing them into place. Turn levelers or casters clockwise (facing bottom of base plate) to tighten and counter clockwise to loosen.

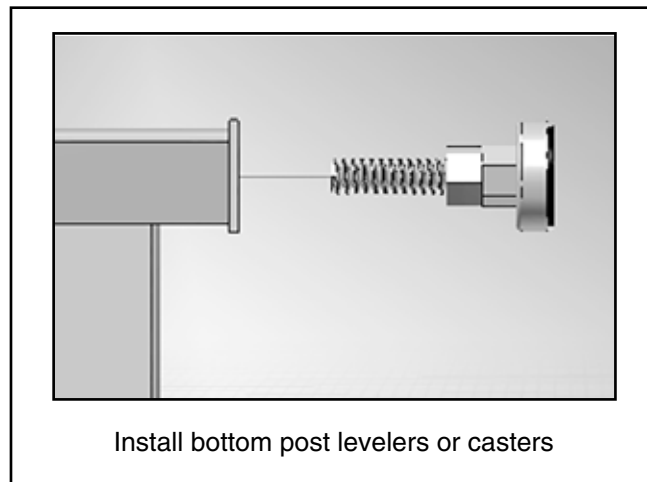

2 Assemble the End Kit

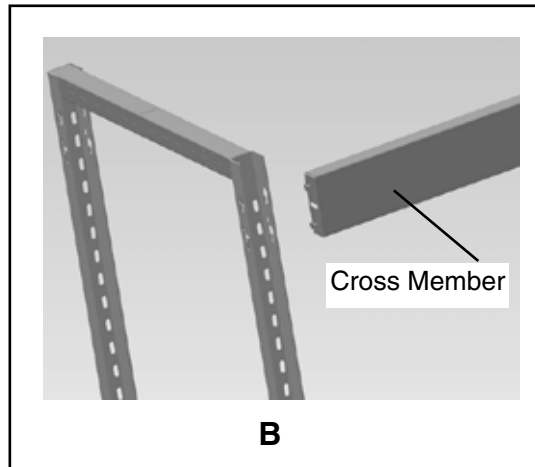
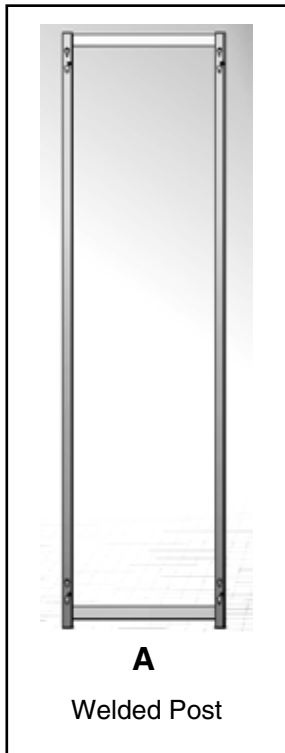

Take one cross member and insert the round pegs from the cross member into the slotted hole of the Welded Post and pull down as shown in 'B'. Then take a nut, lock washer and bolt to fasten Welded Post as shown in 'C'.

Next, take another cross member and do the same until you have all four Cross Members attached and bolted to the Welded Posts.

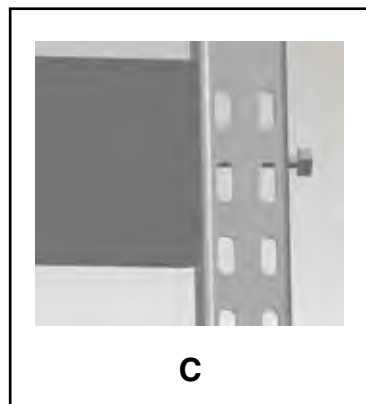

Take another Welded Post and attach it to each of the Cross Members, inserting the pegs into the corresponding slotted holes and pulling down until they line up with the bolt holes as shown in 'D'. Fasten with 1/4 inch bolts, nuts and washers.

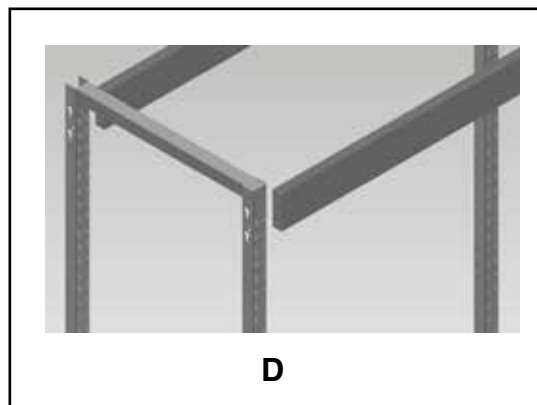
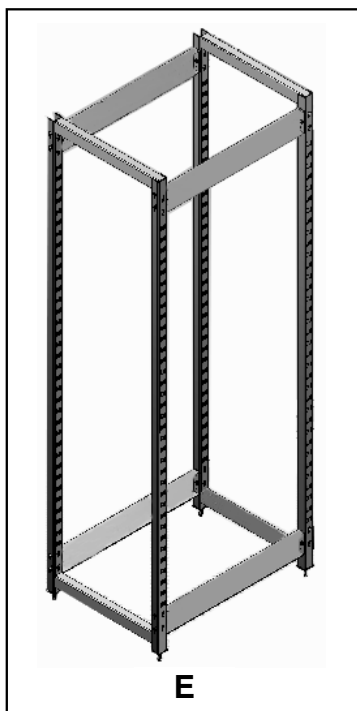

3 L-Bracket Installation

The space needed between the Cooler Wall and the Welded Post is 4 inches.

Two L-Brackets are installed at top of each post. Line up Slots in L-Bracket with Holes on Welded Post. With one washer already on each 8-32 bolt, insert 2 bolts through the Slots. Install 1 L-Bracket at bottom of each post.

Place two washers on each bolt before inserting bolts through the holes in the Welded Post. Bolts should come completely through the tube. Install Flange Nuts on to each bolt and tighten. Use #12-11 Sheet Metal Screws to fasten Welded Post to Cooler Wall. Refer to illustration on next page.

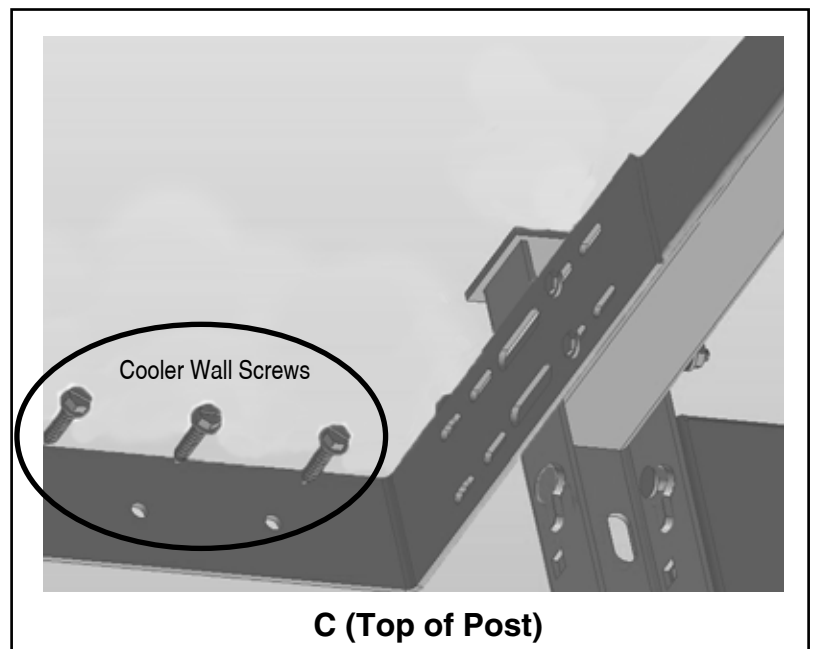
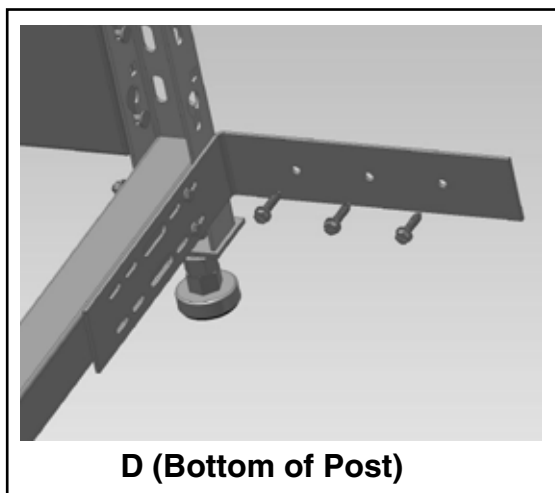
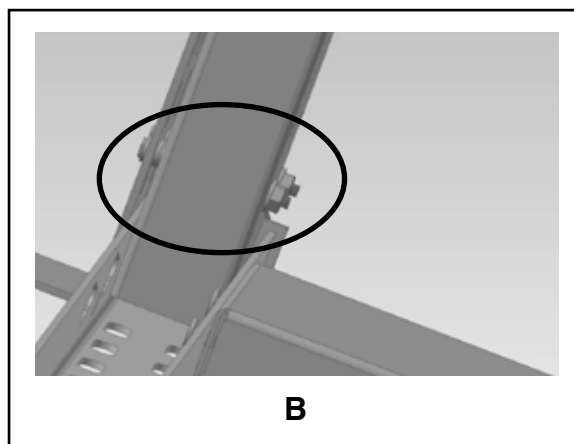
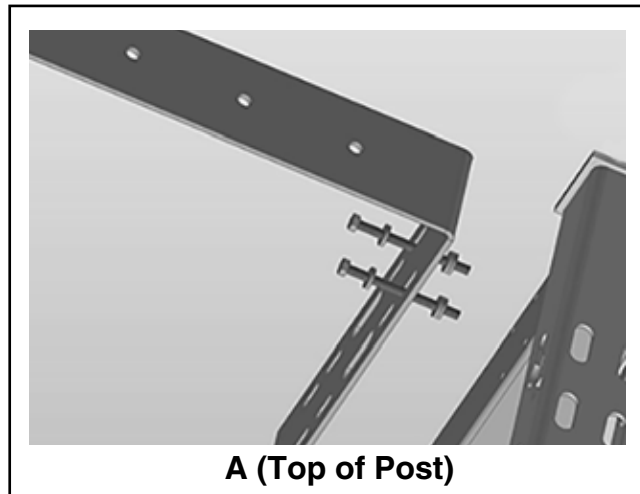

- 4** Assemble the Center Kit similar to Step 2 and attach to End Kit. Continue installing Center Kits for the remaining length of the doors. Ensure shelf kits are level - adjust levelers if needed.

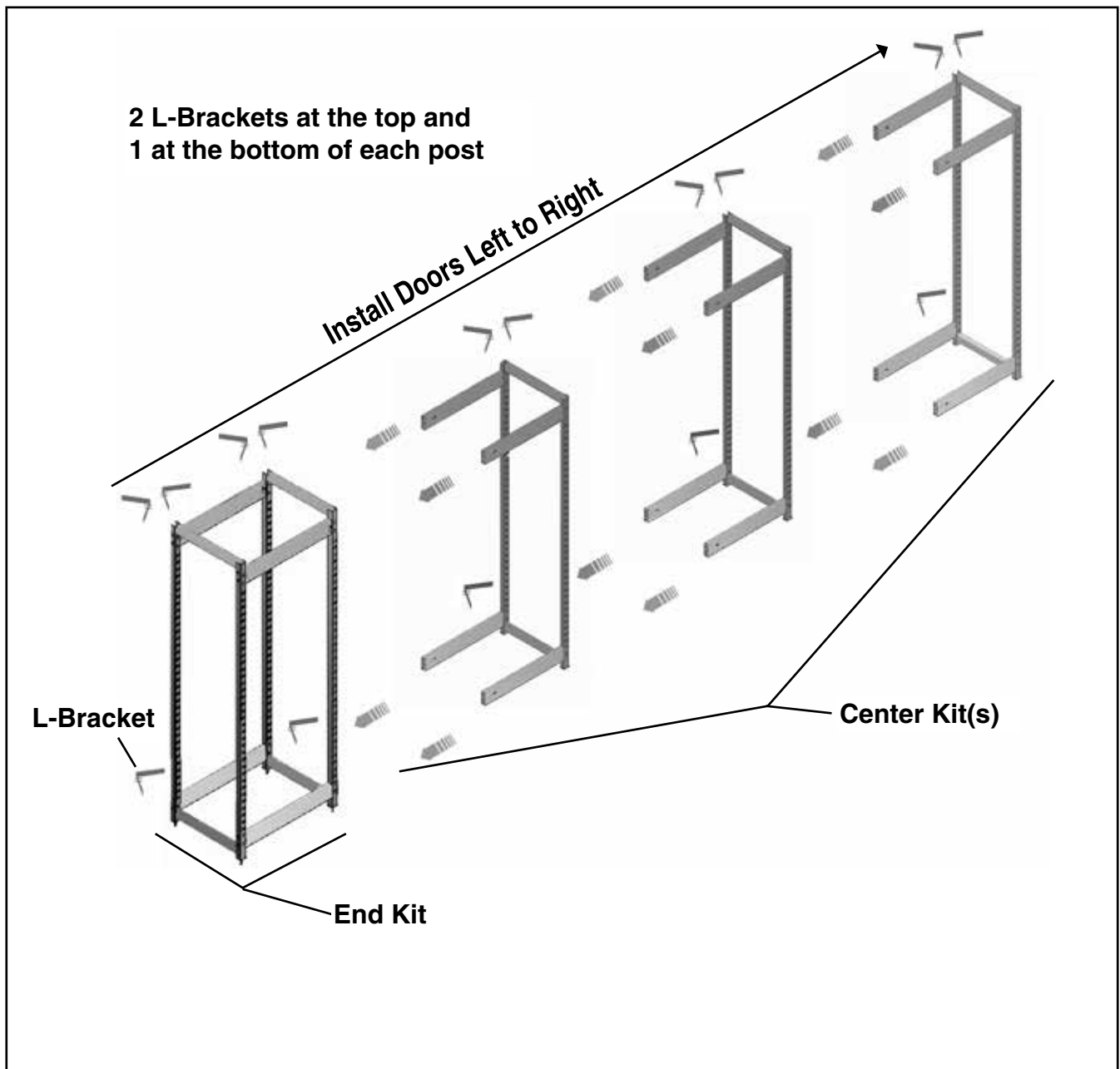

5 Install Shelves

1. Always start from bottom shelf. Shelves can be installed tilted or flat. 5 to 7 shelves may be installed between posts.

2. Bring the shelf in at an angle as shown in 'A'. Front shelf slots can be positioned as many as two slots lower than back shelf slots.

3. Find the desired slots for the front two notches. Insert the tip of the notches into the slots as shown in 'B'.

4. Find the desired slots for the back two notches, and insert all 4 corners. (Shelves can also be flat)

5. Insert Clevis pin into front right and back left or front left and back right .250" notched holes. Then secure Clevis pins with Hitch pins as shown to secure the shelf.

6. Repeat until all shelves are installed.

