

MINIMUM CLEARANCE REQUIREMENTS:

ACTUAL CLEARANCE REQUIREMENTS ARE DEPENDENT UPON AUTHORITY HAVING JURISDICTION, AND MAY EXCEED DIMENSIONS SHOWN.

42" CLEARANCE BETWEEN CONTROL PANEL AND ANY WALL

48" CLEARANCE BETWEEN CONTROL PANEL AND ANY LIVE PANEL

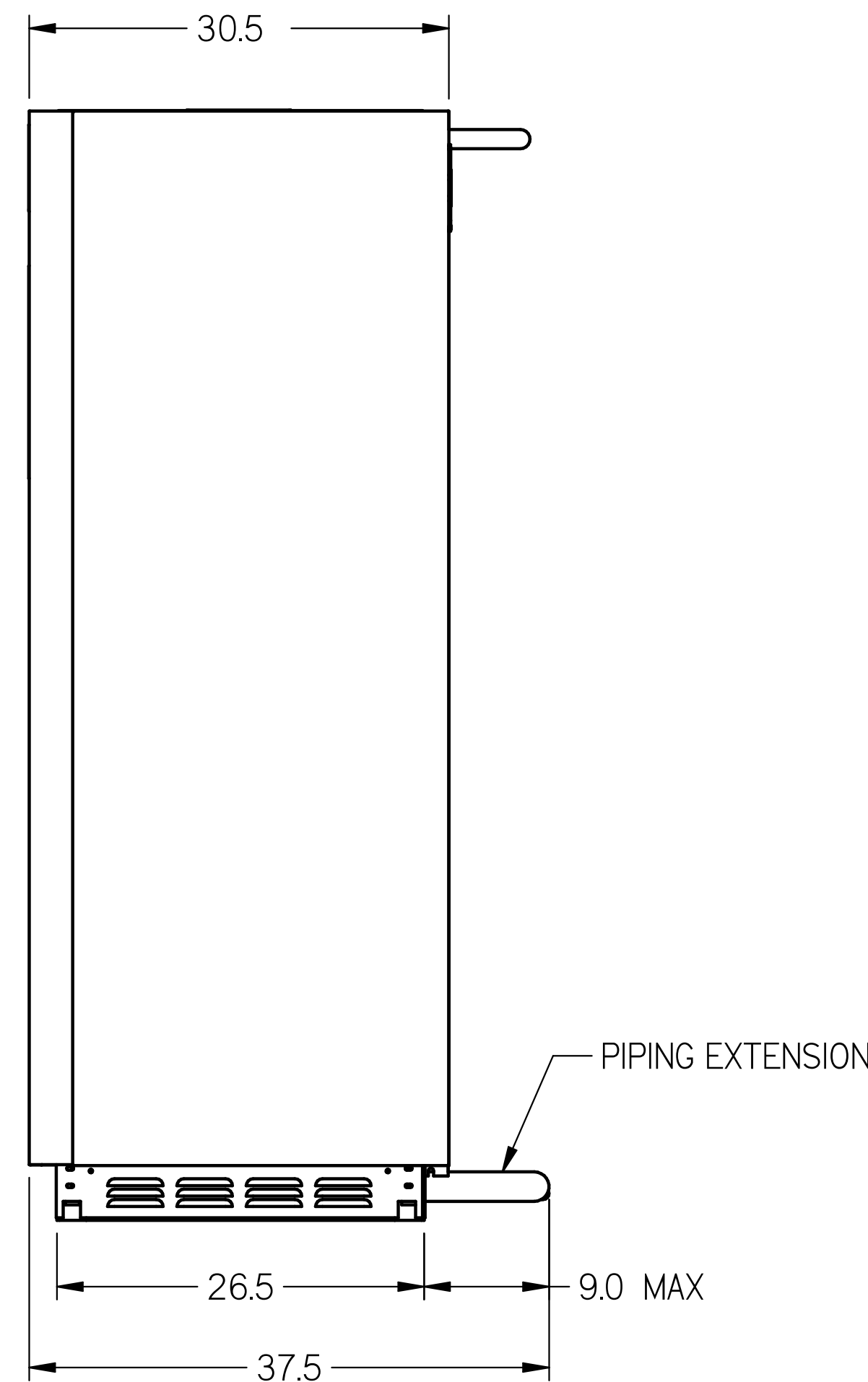
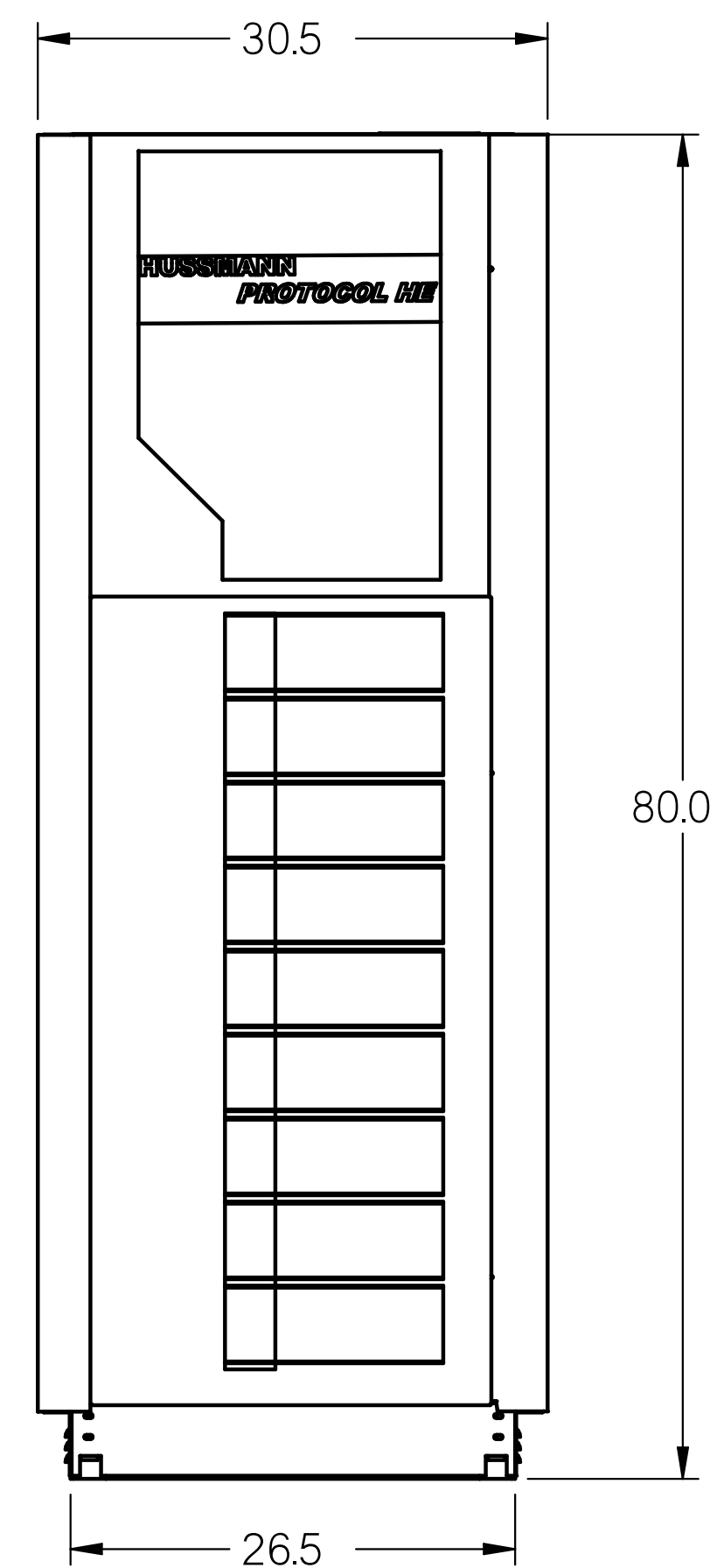
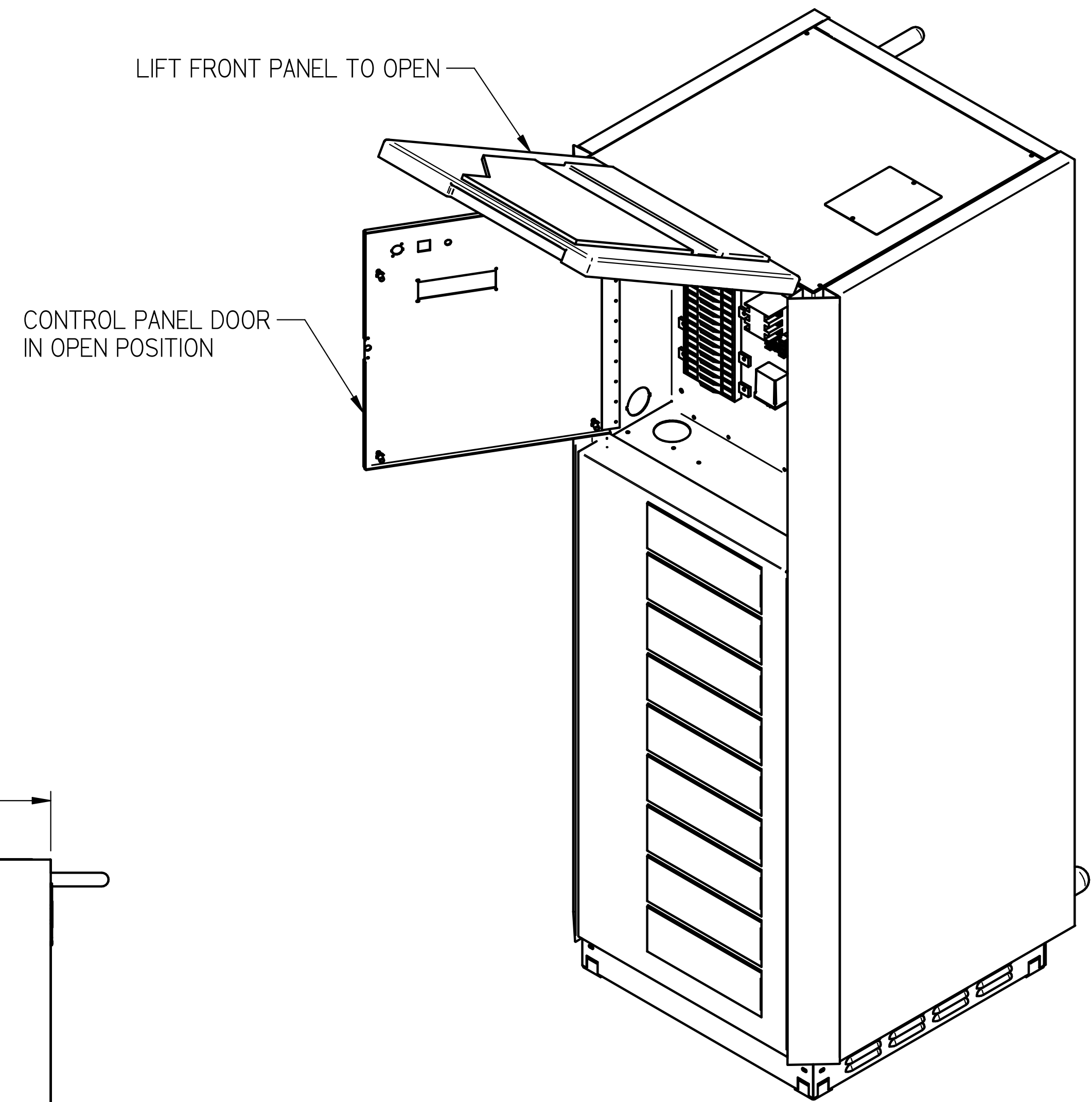
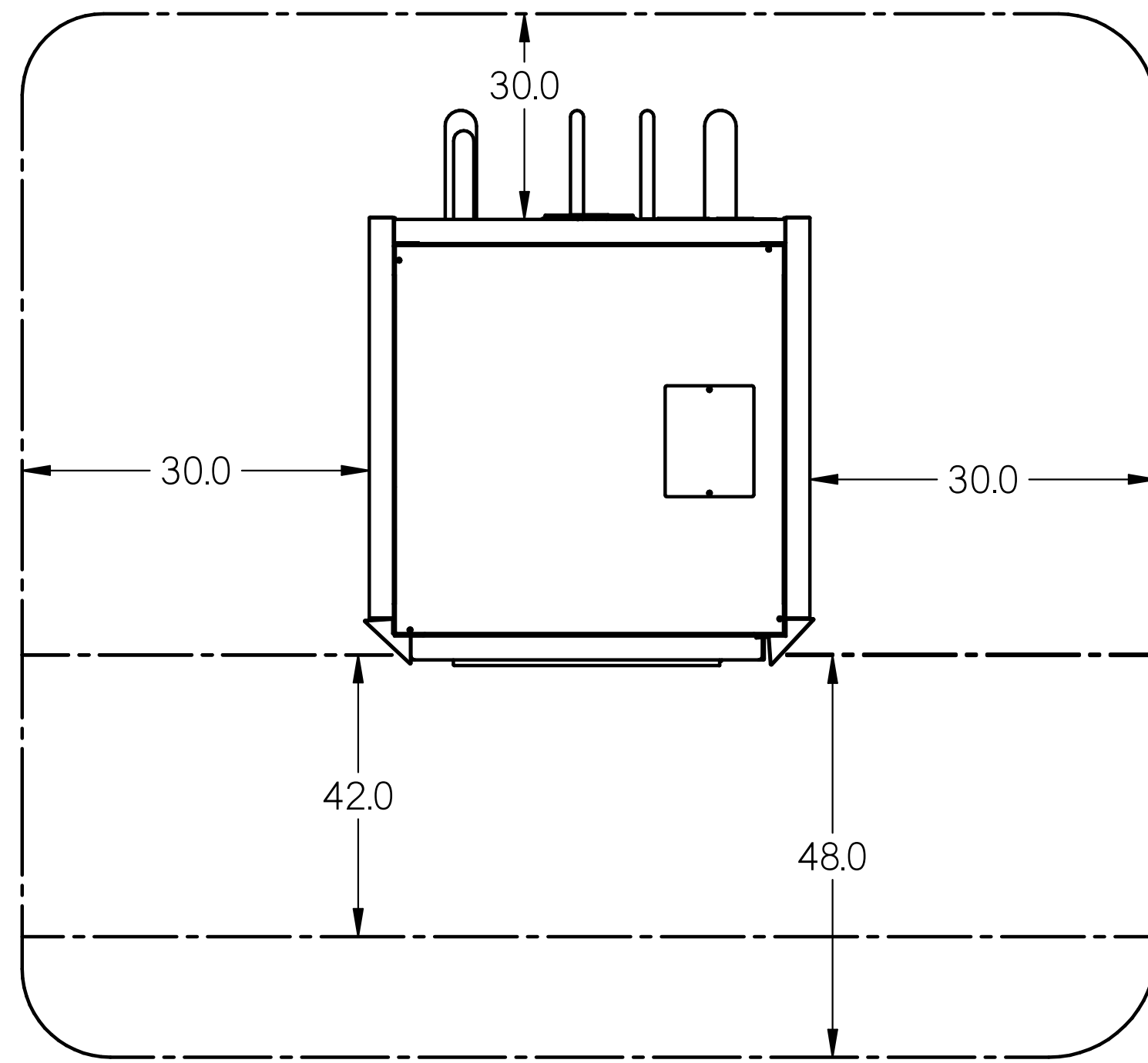

NOTES:

1. IT IS THE RESPONSIBILITY OF THE INSTALLING CONTRACTOR TO ENSURE THAT THE FINAL EQUIPMENT INSTALLATION MEETS ALL APPLICABLE CODE REQUIREMENTS.
2. ILLUSTRATION SHOWN IS FOR GENERAL REPRESENTATION ONLY. ACTUAL PRODUCT WILL VARY DEPENDENT UPON APPLICATION.
3. OVERALL DIMENSIONS: 30.5 L X 37.5 W X 80.0 H.
4. APPROXIMATE WEIGHT OF UNIT = 1,500 LBS.

INFORMATION SUBJECT TO CHANGE

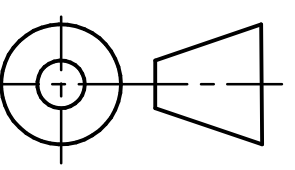
DIMENSIONS ARE IN INCHES. DATE DRAWN: 2017/09/14		HUSSMANN [®]	
 THIRD ANGLE PROJECTION		ASSM 2 WIDE VERTICAL PROTOCOL	
		DOC PD-000000061	REV B
SHEET 1 OF 2			

SWN 1.0 SUBMITTAL SHEET SIZE D

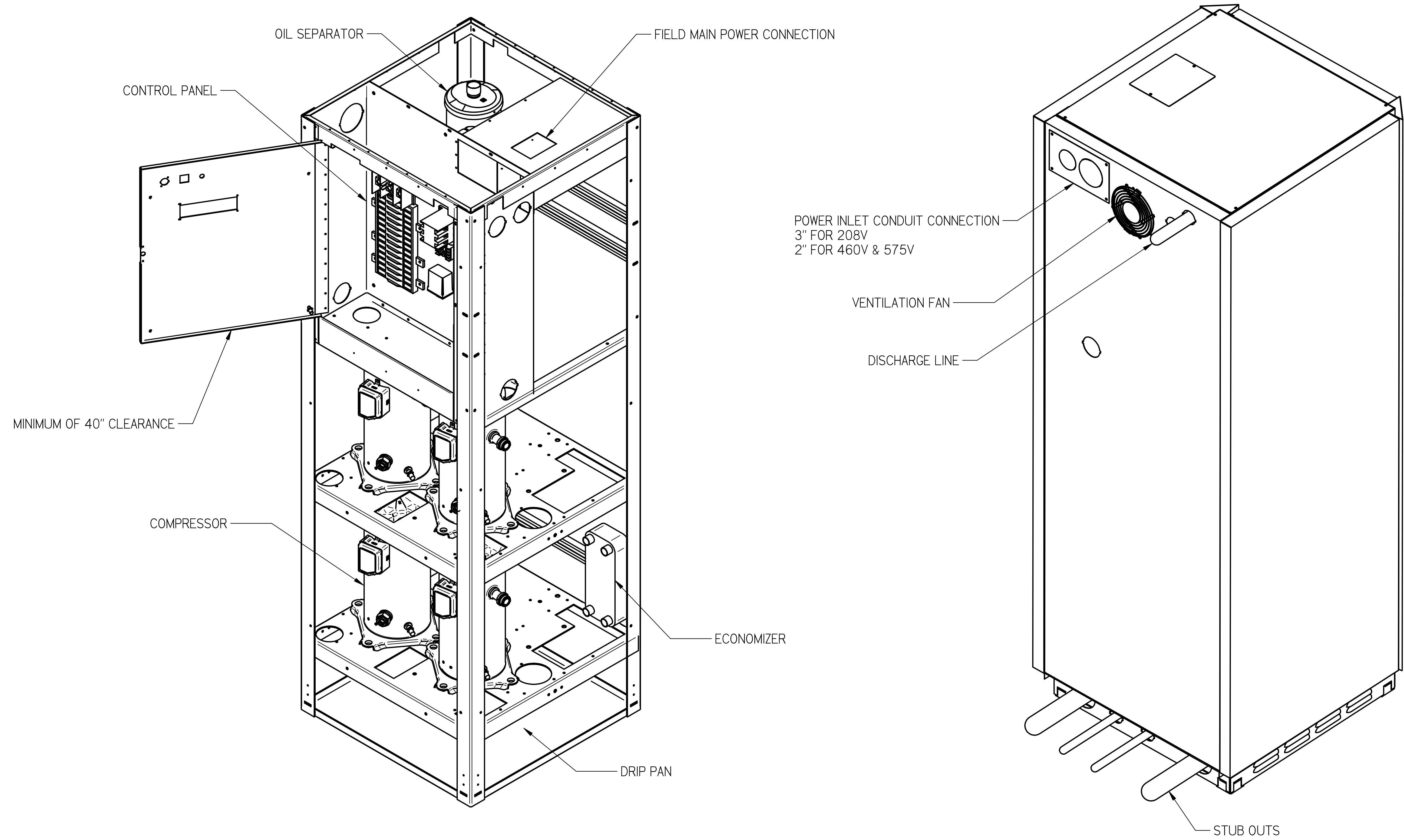

NOTES:

1. IT IS THE RESPONSIBILITY OF THE INSTALLING CONTRACTOR TO ENSURE THAT THE FINAL EQUIPMENT INSTALLATION MEETS ALL APPLICABLE CODE REQUIREMENTS.
2. ILLUSTRATION SHOWN IS FOR GENERAL REPRESENTATION ONLY. ACTUAL PRODUCT WILL VARY DEPENDENT UPON APPLICATION.
3. OVERALL DIMENSIONS: 30.5 L X 37.5 W X 80.0 H.
4. APPROXIMATE WEIGHT OF UNIT = 1,500 LBS.

INFORMATION SUBJECT TO CHANGE

DIMENSIONS ARE IN INCHES. DATE DRAWN: 2017/09/14		HUSSMANN [®]
THIRD ANGLE PROJECTION		
SHEET 2 OF 2		ASSM 2 WIDE VERTICAL PROTOCOL
		DOC PD-000000061 REV B

SWN 1.0 SUBMITTAL SHEET SIZE D