

*Insight standard field electrical connections
are at the top left of the merchandiser*

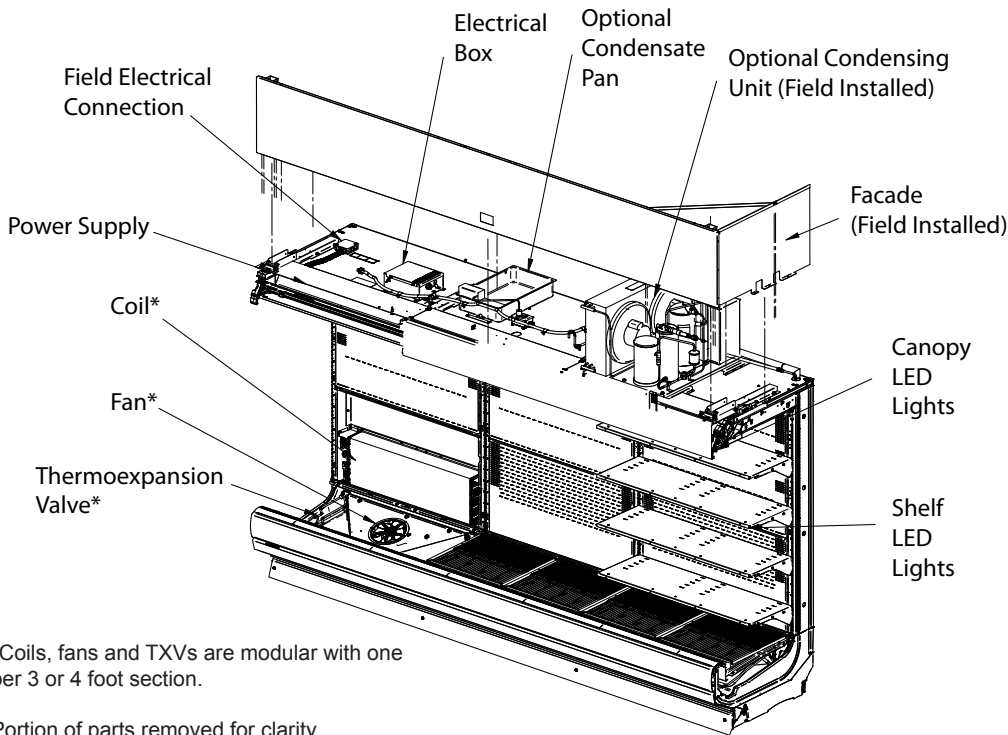

*Coils, fans and TXVs are modular with one per 3 or 4 foot section.

Portion of parts removed for clarity.

12 foot merchandiser shown.

NSF Certification

This merchandiser model is manufactured to meet NSF/ANSI (National Sanitation Foundation) Standard #7 requirements for construction, materials and cleanability.



Performance Data	Page 2	Estimated Shipping Weights	Page 6
Product Data (AHRI Statistics)	Page 2	Shelf Options	Page 6
Cross Section	Page 3	Replacement Parts List	Page 7
Plan View	Page 4	Wiring Diagrams	Page 8
Electrical Loads	Page 5	Computing Refrigeration and Electrical Load	Page 11
		Revision History	Page 11

Data sheet-Insight IDF5NV

We reserve the right to change or revise specifications and product design in connection with any feature of our products. Such changes do not entitle the buyer to corresponding changes, improvements, additions or replacements for equipment previously sold or shipped.

Insight IDF5NV
Dairy / Delicatessen / Meat

Refrigeration Data ¹

IDF5NV		Optimal Shelf Life				Energy Comparison
Application		Dairy / Deli / Beverage / Produce	Convertible / Meat	NSF Type 2 Ambient ³	Pegs ⁴	AHRI 1200 Rating Point ⁵
Unlit Shelves	Discharge Air °F (°C)	33 (0.55)	32 (0.0)	32 (0.0)	N/A	35 (1.67)
	Average Evaporator °F (°C) ²	27 (-2.78)	26 (-3.33)	25 (-3.89)	N/A	29 (-1.67)
	Parallel Btu/hr/ft (Watts/m) ⁶	1318 (1267)	1322 (1271)	1601 (1539)	N/A	1214 (1167)
	Conventional Btu/hr/ft (Watts/m) ⁶	1395 (1341)	1400 (1346)	1695 (1630)	N/A	1285 (1236)
Lit Shelves	Discharge Air °F (°C)	33 (.56)	32 (0.0)	32 (0.0)	N/A	35 (1.67)
	Average Evaporator °F (°C) ²	27 (-2.77)	26 (-3.33)	25 (-3.89)	N/A	29 (-1.67)
	Parallel Btu/hr/ft (Watts/m) ⁶	1336 (1285)	1341 (1290)	1620 (1558)	N/A	1233 (1185)
	Conventional Btu/hr/ft (Watts/m) ⁶	1415 (1361)	1420 (1365)	1715 (1649)	N/A	1305 (1255)
Fan Speed ⁶	ID5NV6 (8.25")	1200 ⁷	1300 ⁷	1300 ⁷	1300 ⁷	1200 ⁷
	ID5NV4, 8, 12 (8.25")	1200 ⁷	1300 ⁷	1300 ⁷	1300 ⁷	1200 ⁷

Notes:

- All data based on store temperature and humidity that does not exceed NSF Type 1 ambient conditions of 75°F and 55% relative humidity except where noted.
- Average evaporator temperature shown. Use dew point for high glide refrigerants for unit sizing. Care should be taken to use the dew point in PT tables for measuring and adjusting superheat. Adjust evaporator pressure as needed to maintain discharge air temperature shown.
- Data for operation in NSF Type 2 ambient of 80°F and 55% relative humidity.
- Husmann Peg Shelves for Dairy/Deli applications only
- AHRI 1200 Rating Point for energy consumption comparison only.
- Add 10 Btu/hr/ft (9.6 Watts/m) per shelf row for LED shelf light fixtures.
- Some lengths and/or applications require optional fan speed control kits applied by the Husmann Product Configurator.

Defrost Data

Frequency (hours between defrost)	6
Defrost Water ⁹	10.0 lb/ft/day (14.9 kg/m)
⁹ (± 15% based on case configuration and product loading).	
OFFTIME	IDF5NV
Time (minutes)	20
ELECTRIC OR GAS	Not Available

Conventional Controls

IDF5NV
Low Pressure Backup Control CI/CO ¹⁰
20°F /10°F -6.7°C / -12.2°C
Indoor Unit Only, Pressure Defrost Termination ¹⁰
48°F (8.9°C)

¹⁰ Use a Temperature Pressure Chart to determine PSIG conversions.

Estimated Charge ¹¹ IDF5NV

4 ft	0.6 lb	9.6 oz	0.3 kg
6 ft	1.1 lb	17.6 oz	0.5 kg
8 ft	1.5 lb	24 oz	0.7 kg
12 ft	2.9 lb	46.4 oz	1.3 kg

¹¹ This is an average for all refrigerant types. Actual refrigerant charge may vary by approximately half a pound.

Product Data

Gross Refrigerated Volume ¹² (Cu Ft/Ft)	9.8 ft ³ /ft (0.89 m ³ /m)
AHRI Total Display Area ¹³ (Sq Ft/Ft)	5.05 ft ² /ft (1.39 m ² /m)
Shelf Area ¹⁴ (Sq Ft/Ft)	8.10 ft ² /ft (2.47 m ² /m)

¹² AHRI Gross Refrigerated Volume: Refrigerated Volume/Unit of Length, ft³/ft [m³/m]

¹³ Computed using AHRI 1200 standard methodology: Total Display Area, ft² [m²]/Unit of Length, ft [m]

¹⁴ Shelf surface area is composed of bottom deck plus standard shelf complement for this model: (4) rows of 16-in. shelves

Insight Freedom Multideck Merchandiser, 5 Display Levels, Narrow Bottom, Ultra Low Height Front

Insight IDF5NV
Dairy / Delicatessen / Meat

DOE 2017
Energy Efficiency
Compliant

Husmann refrigerated merchandisers configured for sale for use in the United States meet or surpass the requirements of the DOE 2017 energy efficiency standards.

Dimensions shown as in. and (mm).

Other optional kits (top piping and vent fans) add to the overall case height.

A minimum 1 1/2-in. clearance required to remove raceway cover, 6 1/2-in. for full access. See the Installation manual for instructions.

3-in. between back to back cases.

Shelf complement shown as tested:
Four rows of 16-in. shelves spaced equally between bottom display pan and interior top panel.

Shown with Ellipse Option Bumper.

OPTIONAL RAIL LIGHT

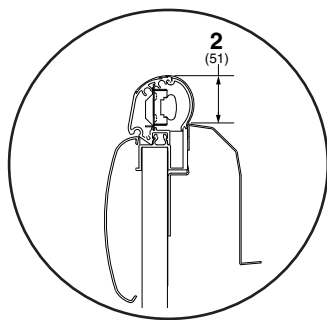

Rail light cannot be used with glass front option.

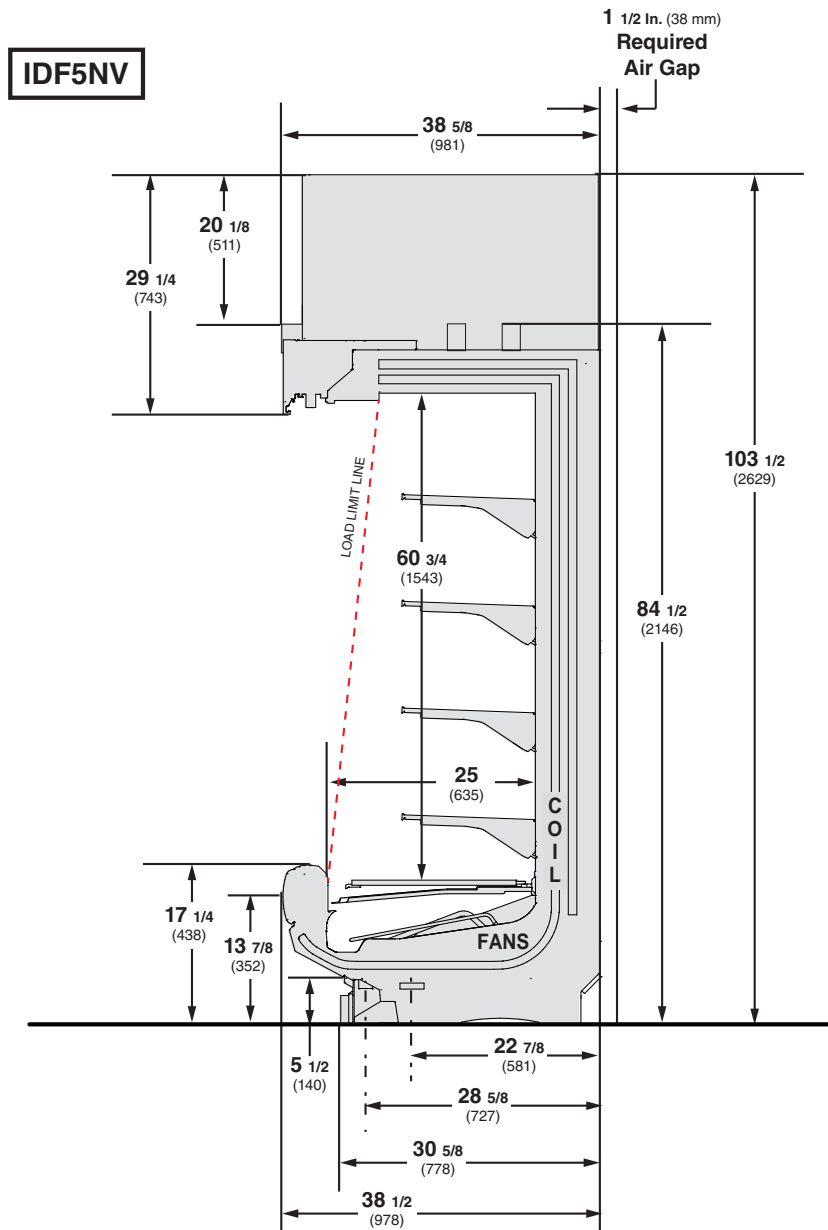

NSF Certification

This merchandiser model is manufactured to meet NSF/ANSI (National Sanitation Foundation) Standard #7 requirements for construction, materials and cleanability.

Engineering Plan View

IDF5NV

Dimensions shown as in. and (mm).

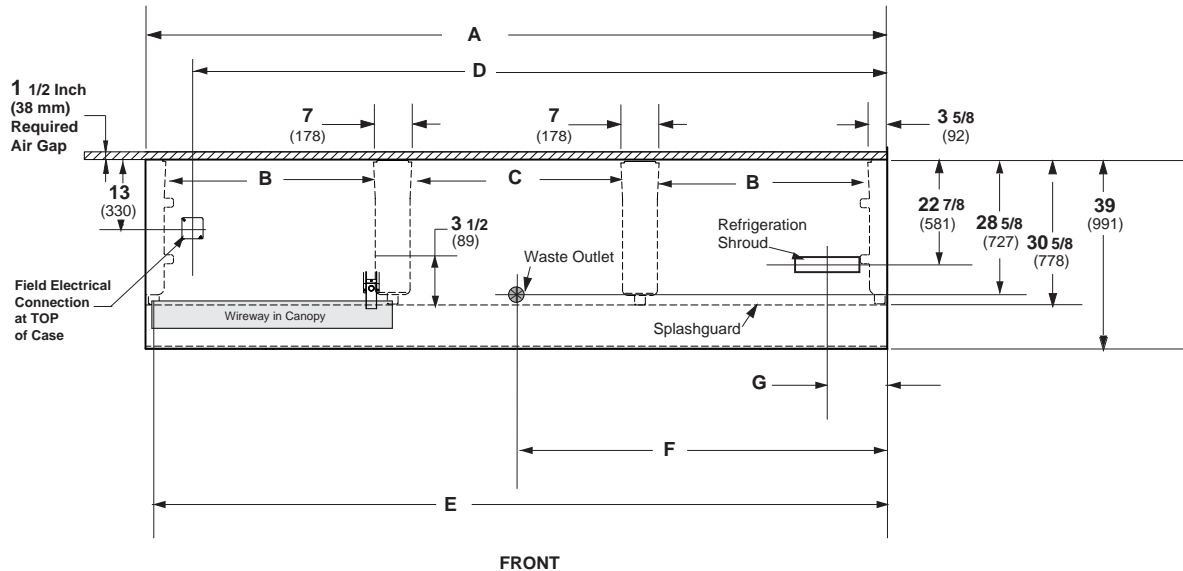

(12 Foot Model shown above)

	4 ft	6 ft	8 ft	12 ft
General				
(A) Case Length (without ends or partitions) (Each end and insulated partition adds 1 1/2 in. (38 mm) to case line up.)	48 1/8 (1222)	72 1/4 (1835)	96 1/4 (2445)	144 3/8 (3668)
Maximum O/S dimension of case back to front (includes bumper)	38 5/8 (981)	38 5/8 (981)	38 5/8 (981)	38 5/8 (981)
Back of case to front of splashguard	30 5/8 (778)	30 5/8 (778)	30 5/8 (778)	30 5/8 (778)
(B) Distance between edges of external legs and center legs	NA	29 (737)	41 (1041)	41 (1041)
(C) Distance between edges of center legs	41 1/8 (1045)	NA	NA	41 1/8 (1045)
Distance between front legs and splashguard	3 1/4 (83)	3 1/4 (83)	3 1/4 (83)	3 1/4 (83)
Electrical Service (Field Electrical Wiring Connection)				
(D) RH End of case to center of Field Electrical Wiring Connection (top of case)	39 3/8 (1000)	63 1/2 (1613)	87 1/2 (2223)	135 1/2 (3442)
Back of case to center of Field Electrical Wiring Connection	13 (330)	13 (330)	13 (330)	13 (330)
Length of electrical wireway	44 5/8 (1133)	33 1/2 (851)	45 7/8 (1165)	45 7/8 (1165)
(E) RH end of case to LH end of electrical wireway (top of case)	46 1/2 (1181)	70 1/2 (1791)	94 1/2 (2400)	142 5/8 (3630)
Waste Outlets				
(F) RH End of case to the center of waste outlet	24 1/8 (613)	24 1/8 (613)	24 1/8 (613)	72 1/4 (1835)
Back O/S of case to center of waste outlet(s)	28 5/8 (727)	28 5/8 (727)	28 5/8 (727)	28 5/8 (727)
Schedule 40 PVC drip pipe	1 1/4 (32)	1 1/4 (32)	1 1/4 (32)	1 1/4 (32)
Refrigeration Shroud				
(G) Back of case to center of refrigeration shroud	22 7/8 (581)	21 1/8 (537)*	22 7/8 (581)	22 7/8 (581)
End of case to center of refrigeration shroud	9 1/2 (241)	7 5/8 (194)*	9 1/2 (241)	9 1/2 (241)
*6 ft case at a 42° angle parallel to the plenum				

Electrical Data

Number of Fans	4 ft	6 ft	8 ft	12 ft
10.3 in.	1	2	2	3

	Amperes				Watts			
	4 ft	6 ft	8 ft	12 ft	4 ft	6 ft	8 ft	12 ft
Evaporator Fan								
120V 60Hz Energy Efficient	0.40	0.80	0.80	1.20	24	48	48	72
230V 50/60Hz Energy Efficient	0.21	0.42	0.42	0.62	24	48	48	72

Minimum Circuit Ampacity

120V 60Hz Energy Efficient	0.60	1.00	1.00	1.40
230V 50/60Hz Energy Efficient	0.41	0.62	0.62	0.82

Maximum Over Current Protection

120V	20	20	20	20
230V	15	15	15	15

Lighting

ONLY LIGHTING CONFIGURATIONS THAT ARE COMPLIANT WITH THE U.S. DEPT. OF ENERGY (DOE) 2017 REGULATION ARE AVAILABLE FOR SALE FOR USE IN THE U.S.A.

	Amperes				Watts			
	4 ft	6 ft	8 ft	12 ft	4 ft	6 ft	8 ft	12 ft
STANDARD LIGHTING								
EcoShine II Canopy								
1 Row EcoShine II	0.16	0.26	0.32	0.48	19.3	31.6	38.6	58.0
OPTIONAL LIGHTING								
EcoShine II Canopy								
1 Row EcoShine II HO	0.22	0.33	0.44	0.66	26.5	39.5	53.0	79.4
EcoShine II Shelf								
1 Row of Shelves	0.08	0.12	0.16	0.25	9.9	14.1	19.8	29.7
2 Rows of Shelves	0.16	0.23	0.33	0.49	19.8	28.2	39.5	59.3
3 Rows of Shelves	0.25	0.35	0.49	0.74	29.7	42.3	59.3	89.0
4 Rows of Shelves	0.33	0.47	0.66	0.99	39.5	56.4	79.1	118.6
5 Rows of Shelves	0.41	0.59	0.82	1.24	49.4	70.5	98.9	148.3
6 Rows of Shelves	0.49	0.70	0.99	1.48	59.3	84.5	118.6	178.0
EcoShine II Rail Light								
1 Row	0.08	0.12	0.16	0.25	9.9	14.1	19.8	29.7

120V Lighting Circuit Total = Standard Lighting + Total Optional Lighting + Optional Shelf Lighting

230V Lighting Circuit Total = Multiply 120V Lighting Circuit Total by 0.52

Insight IDF5NV
Dairy / Delicatessen / Meat

ENDS or PARTITIONS

Each standard end and each insulated partition adds 1 1/2 in. (38 mm) to case line up. Optional view end with end bumper adds 3 3/4 in. (95 mm).

PHYSICAL DATA

Merchandiser Drip Pipe (in.)	1 1/4
Schedule 40 PVC	
Merchandiser Liquid Line (in.)	3/8
Merchandiser Suction Line (in.)	5/8

ESTIMATED SHIPPING WEIGHT †

Case					Solid End
	4 ft	6 ft	8 ft	12 ft	(each)
lb (kg)	700 (318)	850 (386)	1000 (454)	1400 (635)	100 (45)

† Actual weights will vary according to optional kits included.

Shelf Options

Approved shelf sizes for standard (horizontal, 2-3 position brackets) displays:

- 14-inch
- 16-inch
- 18-inch

Contact engineering for non-standard (4 position brackets or other) display recommendations.

Minimum number of Shelves: 3

Optimal number of Shelves: 4

Maximum number of Shelves: 8

Maximum number of Lighted Shelves: 6

Standard shelf complement for test purposes: (4) rows of 16-in. shelves evenly distributed vertically.

Replacement Parts List

Part #	Description	Part #	Description
FAN ASSEMBLIES		COILS	
Standard HE Fan Assembly		0547187	4 ft, 8 ft, 12 ft
4 Ft, 6 Ft, 8 Ft & 12 Ft		0547186	6 ft only
0535564	10.3 in. Fan Assembly	HONEYCOMB - WHITE	
0534013	Fan Speed Controller	0536831	4 ft, 8 ft, 12 ft
FAN SPEED KEY		0536829	6 ft only
1200 RPM		THERMO-EXPANSION VALVE	
0534355	4 ft, 6ft, 8 ft, 12 ft	Pre-set Adjustable	
1300 RPM		Varies with Refrigerant and Size	
0534357	4 ft, 6ft, 8 ft, 12 ft		
THERMOSTATS			
OPTIONAL			
LED FIXTURES AND POWER SUPPLY			
3079208	Power Supply		
	LED Canopy Fixture		
	<i>Replace with like fixtures.</i>		
	LED Shelf Fixture		
	<i>Replace with like fixtures.</i>		
	LED Rail Fixture		
	<i>Replace with like fixtures.</i>		

NOTE: For LED lighting parts contact your Hussmann service representative at 1-800-922-1919. Please have your model and serial number available. Descriptions including size and color are at [HTTP://WWW.HUSSMANN.COM/EN/PRODUCTS/LED-LIGHTING/PAGES/DEFAULT.ASPX](http://www.hussmann.com/en/products/led-lighting/pages/default.aspx).

FOR ADDITIONAL PARTS INFORMATION, VISIT
[HTTP://WWW.HUSSMANN.COM/EN/PAGES/AFTERMARKET-PARTS.ASPX](http://www.hussmann.com/en/pages/aftermarket-parts.aspx)

Insight IDF5NV
Dairy / Delicatessen / Meat

Fan Wiring
Offtime Defrost

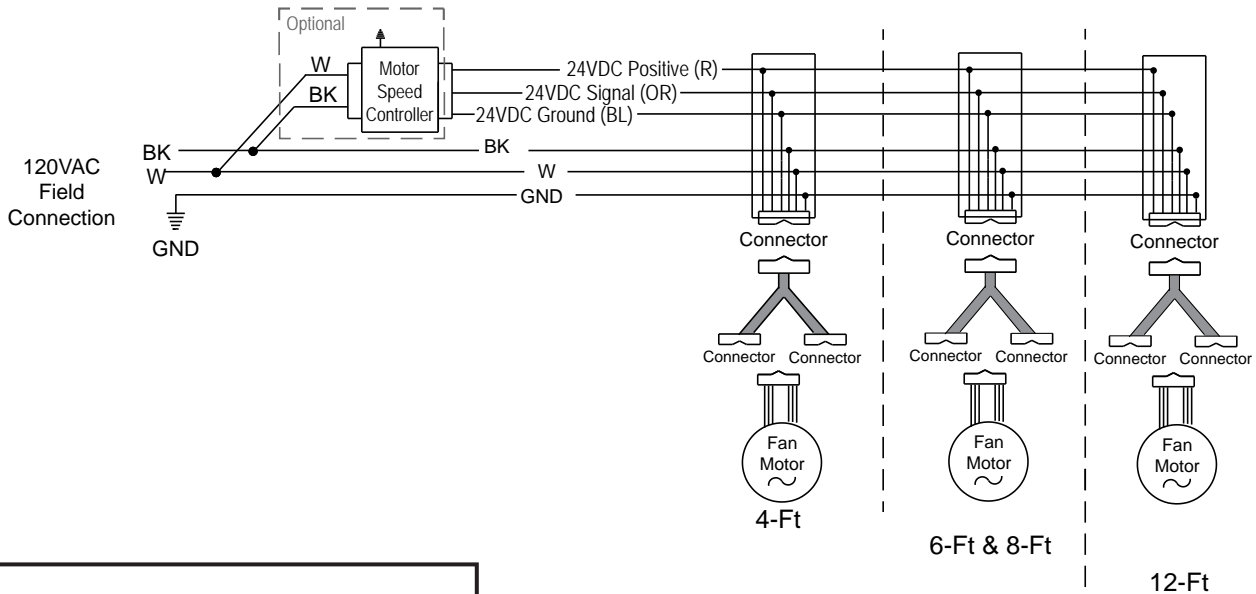

LED Canopy Light Circuits

EcoShine II LED Canopy Lighting - 1 Row

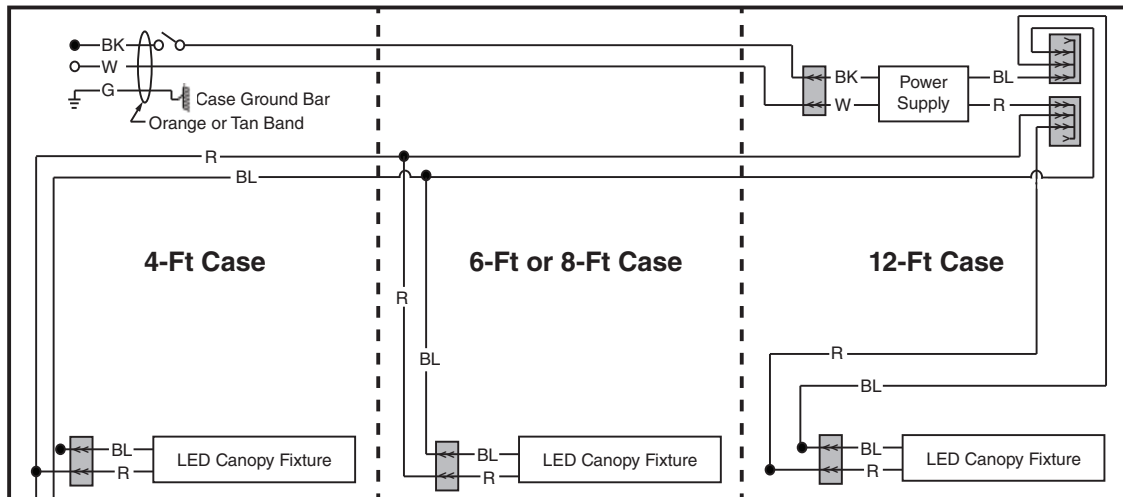

Optional Lighting - EcoShine II LED Rail - 1 Row

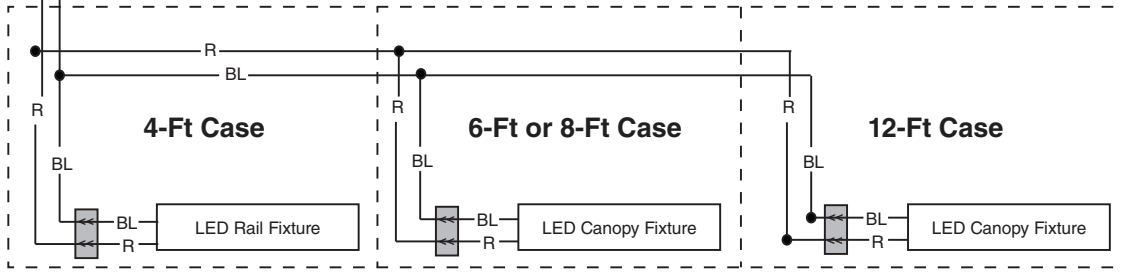

WARNING

All components must have mechanical ground, and the merchandiser must be grounded.

R = Red Y = Yellow G = Green BL = Blue BK = Black W = White
 ● = 120V POWER ○ = 120V NEUTRAL ⚡ = FIELD GROUND ⏏ = CASE GROUND

Optional Shelf Lighting—LED Fixtures

Optional Shelf Harness and LED Light Circuits for 4 or 5 Rows of Shelves

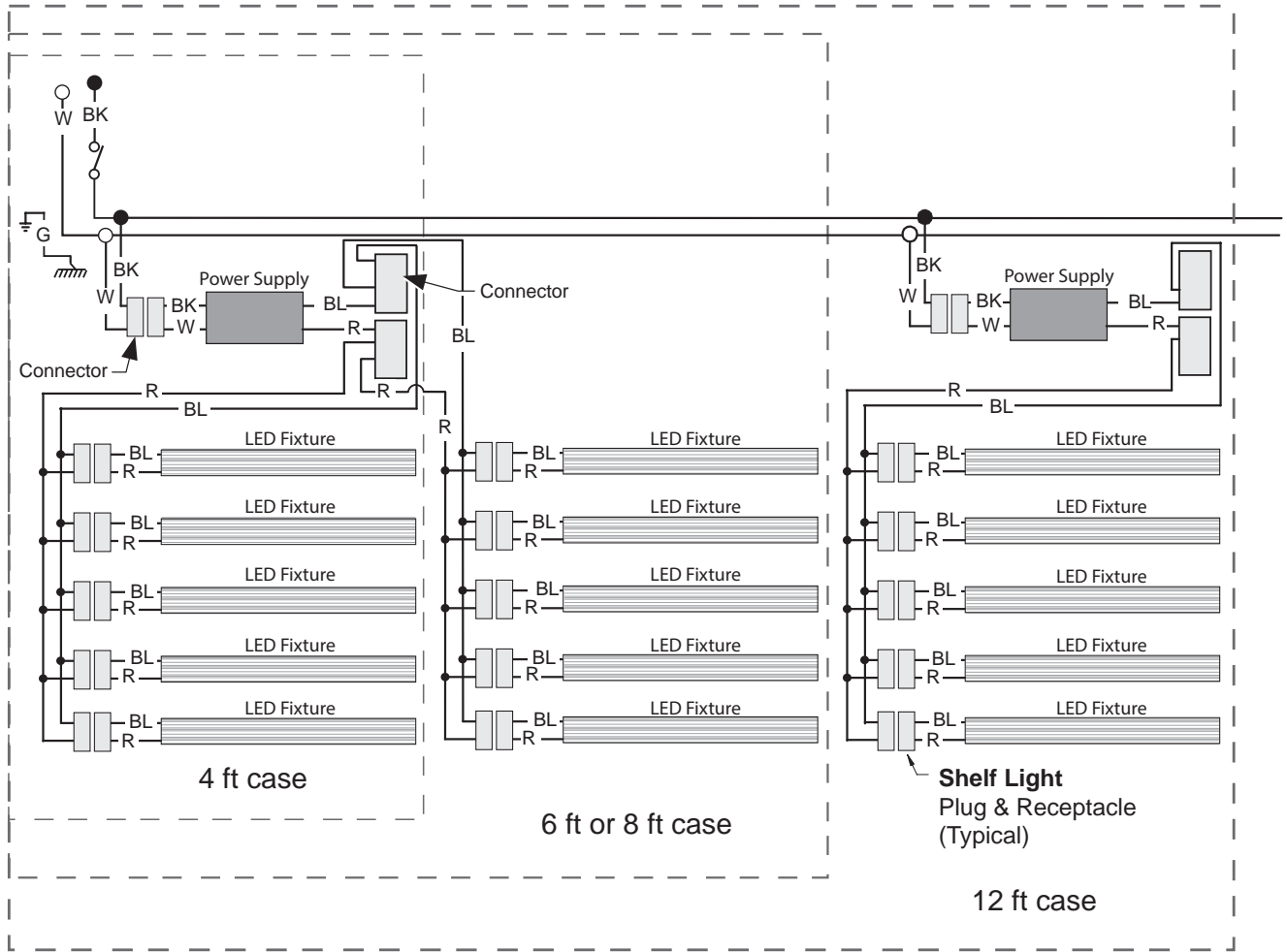

WARNING

All components must have mechanical ground, and the merchandiser must be grounded.

R = Red Y = Yellow G = Green BL = Blue BK = Black W = White
 ● = 120V POWER ○ = 120V NEUTRAL ⊥ = FIELD GROUND ≡ = CASE GROUND

Optional Shelf Lighting—LED Fixtures

Optional Shelf Harness and LED Light Circuits for 6 Rows of Shelves

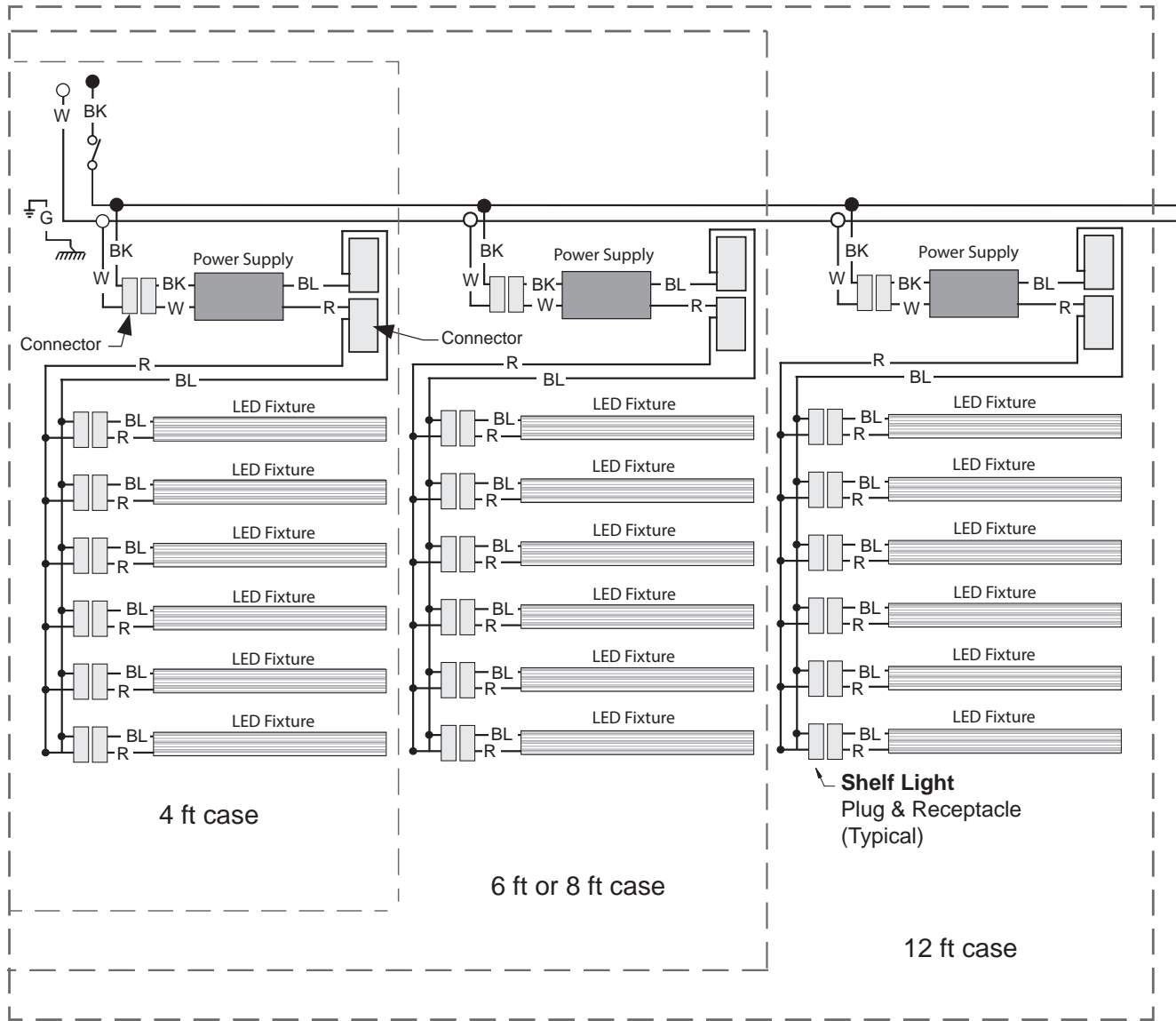

WARNING

All components must have mechanical ground, and the merchandiser must be grounded.

R = Red Y = Yellow G = Green BL = Blue BK = Black W = White
 ● = 120V POWER ○ = 120V NEUTRAL ⊥ = FIELD GROUND *mm* = CASE GROUND

Estimating Refrigeration and Electrical Load (for comparison purposes only)

Case Btu

To determine Btu for a case, refer to the performance data chart on page 2. Select lit or unlit shelves, then select the type of remote refrigeration system (parallel or conventional), which will give Btu/hr/ft. Multiply this number by the length of the case to determine Btu per hour.

Case Electrical

Refer to store legend to determine number of circuits. Lighting should be specified in store legend.

Fan electrical load for a case is computed by selecting the case length and fan voltage on page 6. For example, a 12 ft case uses 3 fans. The store legend specifies fans on a 230V circuit. In this instance, fans use 0.39 Amps and the MCA is 0.59. When applied, ambient fans, anti-sweat heaters, controllers, etc. must be included in the MCA. Include lights in the MCA if lights are on same circuit.

Lights may be on a separate circuit. To estimate lighting load: select case length (12 ft), canopy lighting [standard or optional] (here 0.70 for standard), and shelf or rail lighting [maximum for which case is wired] (1.48 for six shelves); then add together [$0.48 + 1.48 = 1.96$ amps for 120V] (for 230V, multiply $1.96 * 0.52 = 1.02$).

Line Sizing — Refer to store legend.

Hussmann Line Sizing Charts are engineered for use with Hussmann refrigeration equipment.

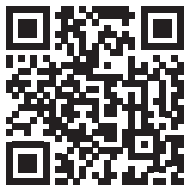

Scan QR code to
access product
information on your
mobile device.

Revision History

Revision A: May 2019: Original Issue