

Insight standard field electrical connections are at the top left of the merchandiser

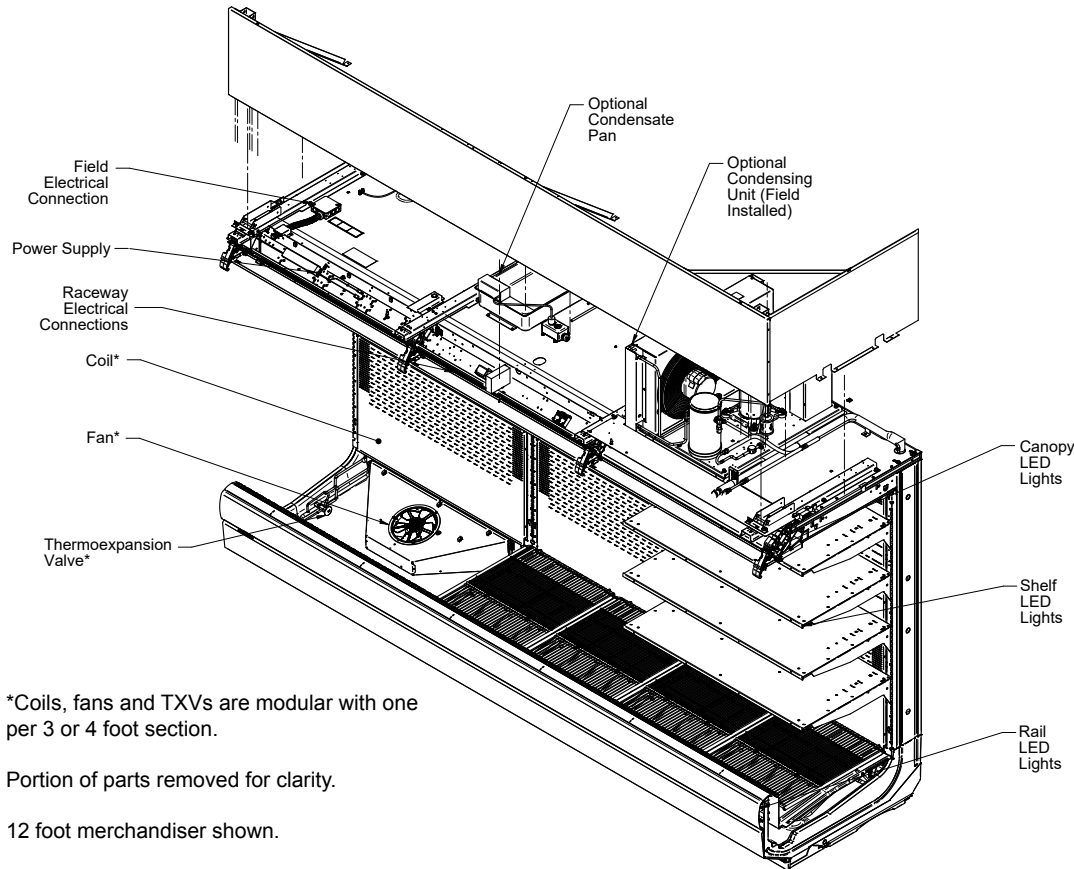

*Coils, fans and TXVs are modular with one per 3 or 4 foot section.

Portion of parts removed for clarity.

12 foot merchandiser shown.



NSF Certification

This merchandiser model is manufactured to meet NSF/ANSI (National Sanitation Foundation) Standard #7 requirements for construction, materials and cleanability.

Performance Data	Page 2	Shelf Options	Page 6
Product Data (AHRI Statistics)	Page 2	Wiring Diagrams	Page 7
Cross Section	Page 3	Computing Refrigeration and Electrical Load	Page 9
Plan View	Page 4	QR Code for Parts and Product Information	Page 9
Electrical Loads	Page 5	Revision History	Page 9
Estimated Shipping Weights	Page 6		

Data sheet-Insight IDF5SM-TE

We reserve the right to change or revise specifications and product design in connection with any feature of our products. Such changes do not entitle the buyer to corresponding changes, improvements, additions or replacements for equipment previously sold or shipped.

Insight IDF5SM-TE
Dairy / Deli / Beverage /
Produce / Meat

Refrigeration Data ¹

IDF5SM-TE		Optimal Shelf Life				Energy Comparison
Application		Dairy/Deli/ Beverage/ Produce	Convertible/ Meat	NSF Type 2 Ambient ³	Pegs ⁴	AHRI 1200 Rating Point ⁵
Unlit Shelves	Discharge Air °F (°C)	32 (0)	31 (-0.55)	30 (-1.11)	30 (1.11)	35 (1.66)
	Average Evaporator °F (°C) ²	28 (-2.22)	27 (-2.77)	26 (-3.33)	26 (3.33)	31 (-0.55)
	Parallel Btu/hr/ft (Watts/m) ⁶	975 (938)	1075 (1034)	1245 (1197)	1190 (1144)	910 (875)
	Conventional Btu/hr/ft (Watts/m) ⁶	1065 (1024)	1170 (1125)	1355 (1303)	1300 (1250)	990 (952)
Lit Shelves	Discharge Air °F (°C)	31 (-0.55)	30 (-1.11)	29 (-1.66)	N/A	34 (1.11)
	Average Evaporator °F (°C) ²	27 (-2.77)	26 (-3.33)	25 (-3.88)	N/A	30 (-1.11)
	Parallel Btu/hr/ft (Watts/m) ^{5,6}	990 (952)	1090 (1048)	1260 (1214)	N/A	920 (885)
	Conventional Btu/hr/ft (Watts/m) ^{5,6}	1080 (1038)	1190 (1144)	1380 (1325)	N/A	1005 (966)
Fan Speed ⁷	IDF5SM-TE (8.25")	1300	1500	1500	1300	1300
	IDF5SM4, 8, 12TE (8.25")	1300	1500 ⁸	1500 ⁸	1300	1300

Notes:

- All data based on store temperature and humidity that does not exceed NSF Type 1 ambient conditions of 75°F and 55% relative humidity except where noted.
- Average evaporator temperature shown. Use dew point for high glide refrigerants for unit sizing. Care should be taken to use the dew point in PT tables for measuring and adjusting superheat. Adjust evaporator pressure as needed to maintain discharge air temperature shown.
- Data for operation in NSF Type 2 ambient of 80°F and 55% relative humidity.
- AHRI 1200 Rating Point for energy consumption comparison only.
- Add 10 Btu/hr/ft (9.6 Watts/m) per shelf row for LED shelf light fixtures.
- Subtract 60 Btu/hr/ft (57.7 Watts/m) for front glass (on applicable models).
- Some lengths and/or applications require optional fan speed control kits applied by the Hussmann Product Configurator.
- This application data is based on testing with the rear of the case exposed to a 38°F cooler. A cooler is required for proper case performance.**
- Reduce refrigeration load by 15% if fitted with CaseShieldPTM.

Defrost Data

Frequency (hours between defrost)	4
Defrost Water ¹⁰	8.1 lb/ft/day (12.1 kg/m)
¹⁰ (± 15% based on case configuration and product loading).	
OFFTIME	IDF5SM-TE
Time (minutes)	20
ELECTRIC OR GAS	Not Available

Conventional Controls

IDF5SM-TE
Low Pressure Backup Control CI/CO ¹¹
20°F / 10°F -6.67°C / -12.2°C
Indoor Unit Only, Pressure Defrost Termination ¹¹
48°F (8.89°C)

¹¹ Use a Temperature Pressure Chart to determine PSIG conversions.

Estimated Charge ¹² IDF5SM-TE

4 ft	5.4 lb	86.4 oz	2.45 kg
6 ft	4.5 lb	72 oz	2.04 kg
8 ft	7.4 lb	118.4 oz	3.35 kg
12 ft	8.8 lb	140.8 oz	3.99 kg

¹² This is an average for all refrigerant types. Actual refrigerant charge may vary by approximately half a pound.

Product Data

Gross Refrigerated Volume ¹³ (Cu Ft/Ft)	11.7 ft ³ /ft (1.08 m ³ /m)
AHRI Total Display Area ¹⁴ (Sq Ft/Ft)	4.27 ft ² /ft (1.30 m ² /m)
Shelf Area ¹⁵ (Sq Ft/Ft)	9.85 ft ² /ft (3.00 m ² /m)

¹³ AHRI Gross Refrigerated Volume: Refrigerated Volume/Unit of Length, ft³/ft [m³/m]

¹⁴ Computed using AHRI 1200 standard methodology: Total Display Area, ft² [m²]/Unit of Length, ft [m]

¹⁵ Shelf surface area is composed of bottom deck plus standard shelf complement for this model: (4) rows of 22-in. shelves

Insight Multideck Merchandiser, Freedom, Standard Bottom, Medium Height Front, Tall, 5 Display Levels

Insight IDF5SM-TE
Dairy / Deli / Beverage / Produce / Meat

DOE 2017
Energy Efficiency
Compliant

Husmann refrigerated merchandisers configured for sale for use in the United States meet or surpass the requirements of the DOE 2017 energy efficiency standards.

Shelf complement shown as tested:

Four rows of 22-in. shelves spaced equally between bottom display pan and interior top panel.

A minimum 1 1/2-in. clearance required to remove raceway cover, 6 1/2-in. for full access. See the Installation manual for instructions.

Shown with Ellipse Option Canopy and Bumper.

3 in. between back-to-back cases.

OPTIONAL RAIL LIGHT

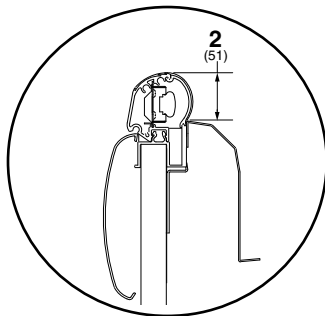

Rail light cannot be used with glass front option.

OPTIONAL GLASS FRONT

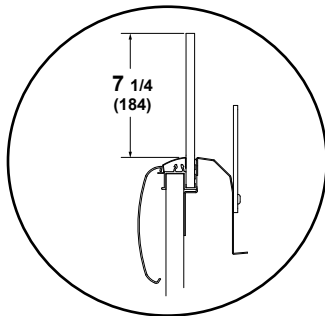

Glass front cannot be used with rail light option.

Dimensions shown as in. and (mm).

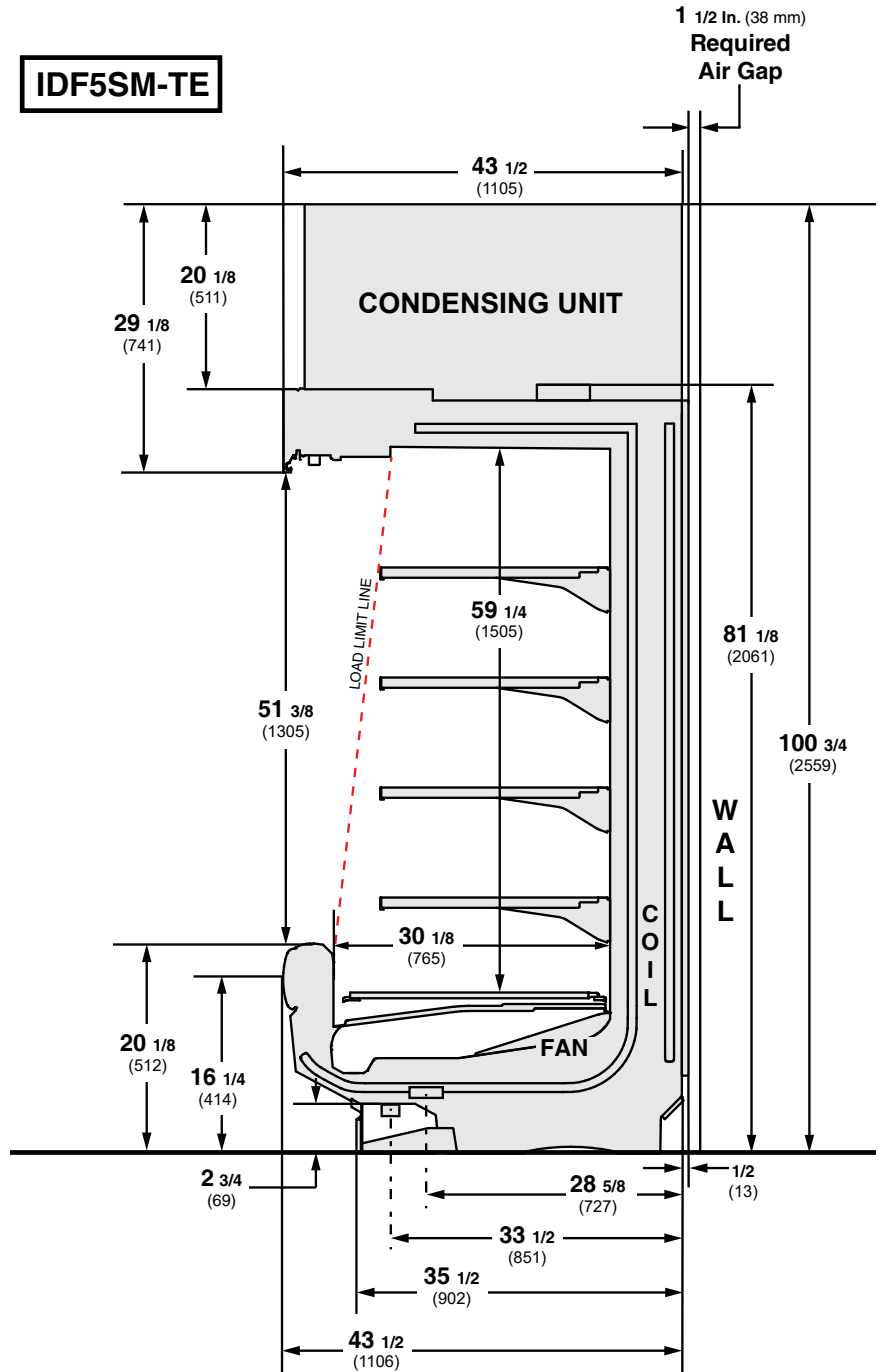

Engineering Plan View

IDF5SM-TE

Dimensions shown as in. and (mm).

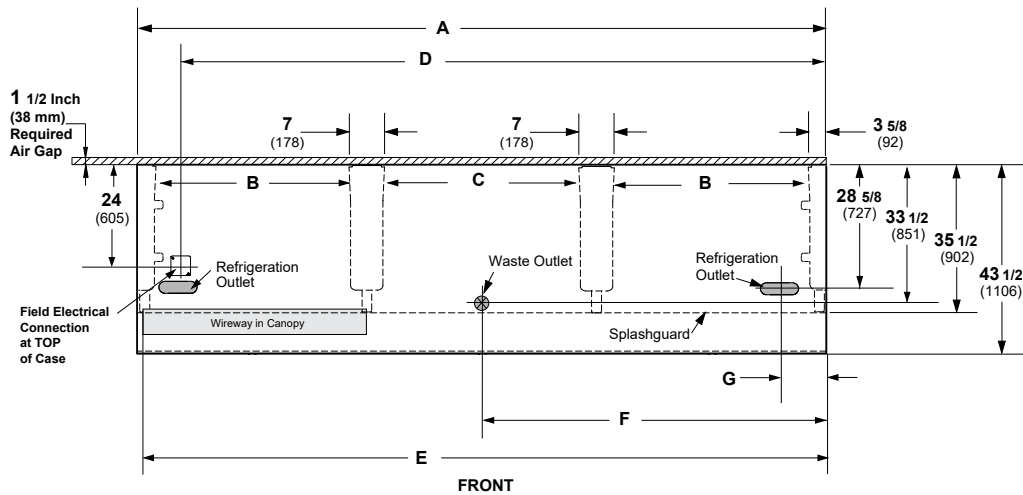

(12 Foot Model shown above)

	4 ft	6 ft	8 ft	12 ft
General				
(A) Case Length (without ends or partitions) (Each end and insulated partition adds 1 1/2 in. (38 mm) to case line up.)	48 1/8 (1222)	72 1/4 (1835)	96 1/4 (2445)	144 3/8 (3668)
Maximum O/S dimension of case back to front (includes bumper)	43 5/8 (1108)	43 5/8 (1108)	43 5/8 (1108)	43 5/8 (1108)
Back of case to front of splashguard	35 5/8 (905)	35 5/8 (905)	35 5/8 (905)	35 5/8 (905)
(B) Distance between edges of external legs and center legs	NA	29 (737)	41 (1041)	41 (1041)
(C) Distance between edges of center legs	41 1/8 (1045)	NA	NA	41 1/8 (1045)
Distance between front legs and splashguard	8 (203)	8 (203)	8 (203)	8 (203)
Electrical Service (Field Electrical Wiring Connection)				
(D) RH End of case to center of Field Electrical Wiring Connection (top of case)	38 (958)	62 (1570)	87 7/8 (2232)	135 3/8 (3451)
Back of case to center of Field Electrical Wiring Connection	24 (605)	24 (605)	24 (605)	24 (605)
Length of electrical wireway	44 5/8 (1133)	33 1/2 (851)	45 7/8 (1165)	45 7/8 (1165)
(E) RH end of case to LH end of electrical wireway (top of case)	46 1/2 (1181)	70 1/2 (1791)	94 1/2 (2400)	142 5/8 (3630)
Waste Outlets				
(F) RH End of case to the center of waste outlet	24 1/8 (613)	24 1/8 (613)	24 1/8 (613)	72 1/4 (1835)
Back O/S of case to center of waste outlet(s)	33 1/2 (851)	33 1/2 (851)	33 1/2 (851)	33 1/2 (851)
Schedule 40 PVC drip pipe	1 1/4 (32)	1 1/4 (32)	1 1/4 (32)	1 1/4 (32)
Refrigeration Outlet				
(G) Back of case to center of refrigeration outlet	29 (737)	29 (737)	29 (737)	29 (737)
End of case to center of refrigeration outlet	8 1/2 (216)	8 1/2 (216)	8 1/2 (216)	8 1/2 (216)

Electrical Data

Number of Fans	4 ft	6 ft	8 ft	12 ft
8.25 in.	1	2	2	3

	Amperes				Watts			
	4 ft	6 ft	8 ft	12 ft	4 ft	6 ft	8 ft	12 ft
Evaporator Fan								
120V 60Hz Energy Efficient	0.25	0.56	0.50	0.75	16	36	32	48
230V 50/60Hz Energy Efficient	0.13	0.27	0.26	0.39	16	36	32	48

Condensate Pump				
120V 60Hz	1.9	1.9	1.9	1.9
230V 50/60Hz	1.0	1.0	1.0	1.0

Minimum Circuit Ampacity				
120V 60Hz Energy Efficient	2.83	3.14	3.08	3.33
230V 50/60Hz Energy Efficient	1.58	1.72	1.71	1.84

Maximum Over Current Protection				
120V	20	20	20	20
230V	15	15	15	15

Lighting

ONLY LIGHTING CONFIGURATIONS THAT ARE COMPLIANT WITH THE U.S. DEPT. OF ENERGY (DOE) 2017 REGULATION ARE AVAILABLE FOR SALE FOR USE IN THE U.S.A.

	Amperes				Watts			
	4 ft	6 ft	8 ft	12 ft	4 ft	6 ft	8 ft	12 ft
LED LIGHTING								
EcoShine ULTRA Canopy Lights								
1 Row EcoShine ULTRA	0.16	0.26	0.36	0.54	19	31	43	64
EcoShine II Canopy Lights								
1 Row EcoShine II	0.16	0.26	0.32	0.48	19	32	39	58
1 Row EcoShine II HO	0.22	0.33	0.44	0.66	27	40	53	79
EcoShine II Shelf Lights								
1 Row of Shelves	0.08	0.12	0.16	0.25	10	14	20	30
2 Rows of Shelves	0.16	0.23	0.33	0.49	20	28	40	59
3 Rows of Shelves	0.25	0.35	0.49	0.74	30	42	59	89
4 Rows of Shelves	0.33	0.47	0.66	0.99	40	56	79	119
5 Rows of Shelves	0.41	0.59	0.82	1.24	49	71	99	148
6 Rows of Shelves	0.49	0.70	0.99	1.48	59	85	119	178
EcoShine II Rail Light-1 Row	0.08	0.12	0.16	0.25	10	14	20	30

120V Lighting Circuit Total = Standard Lighting + Total Optional Lighting + Optional Shelf Lighting

230V Lighting Circuit Total = Multiply 120V Lighting Circuit Total by 0.52

Insight IDF5SM-TE
 Dairy / Deli / Beverage /
 Produce / Meat

ENDS or PARTITIONS

Each standard end and each insulated partition adds 1 1/2 in. (38 mm) to case line up. Optional view end with end bumper adds 3 3/4 in. (95 mm).

PHYSICAL DATA

Merchandiser Drip Pipe (in.)	1 1/4
Schedule 40 PVC	
Merchandiser Liquid Line (in.)	3/8
Merchandiser Suction Line (in.)	5/8

ESTIMATED SHIPPING WEIGHT †

Case	ESTIMATED SHIPPING WEIGHT †					Solid End (each)
	4 ft	6 ft	8 ft	12 ft		
lb (kg)	770 (350)	930 (422)	1080 (490)	1190 (540)		80 (36)

† Actual weights will vary according to optional kits included.

Shelf Options

Approved shelf sizes for standard (horizontal, 2-3 position brackets) displays:

- 18-inch
- 20-inch
- 22-inch
- 24-inch

Contact engineering for non-standard (4 position brackets or other) display recommendations.

Minimum number of Shelves: 3

Optimal number of Shelves: 4

Maximum number of Shelves: 8

Maximum number of Lighted Shelves: 6

Standard shelf complement for test purposes: (4) rows of 22-in. shelves evenly distributed vertically.

Fan Wiring Offtime Defrost

Insight IDF5SM-TE
Dairy / Deli / Beverage /
Produce / Meat

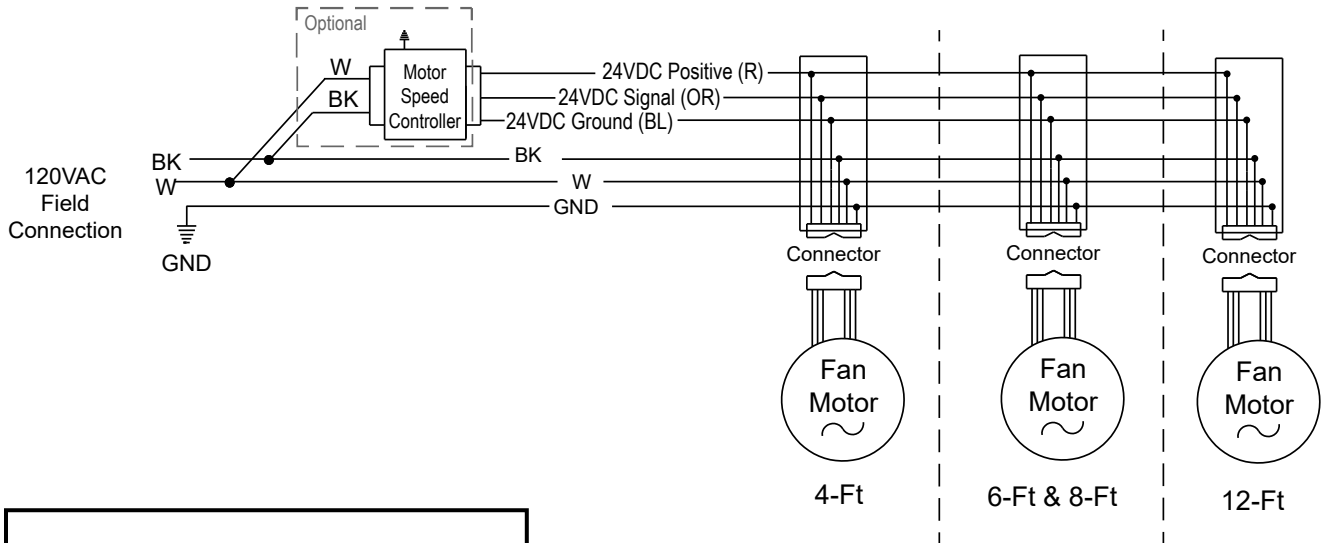

LED Canopy Light Circuits

EcoShine II LED Canopy Lighting - 1 Row

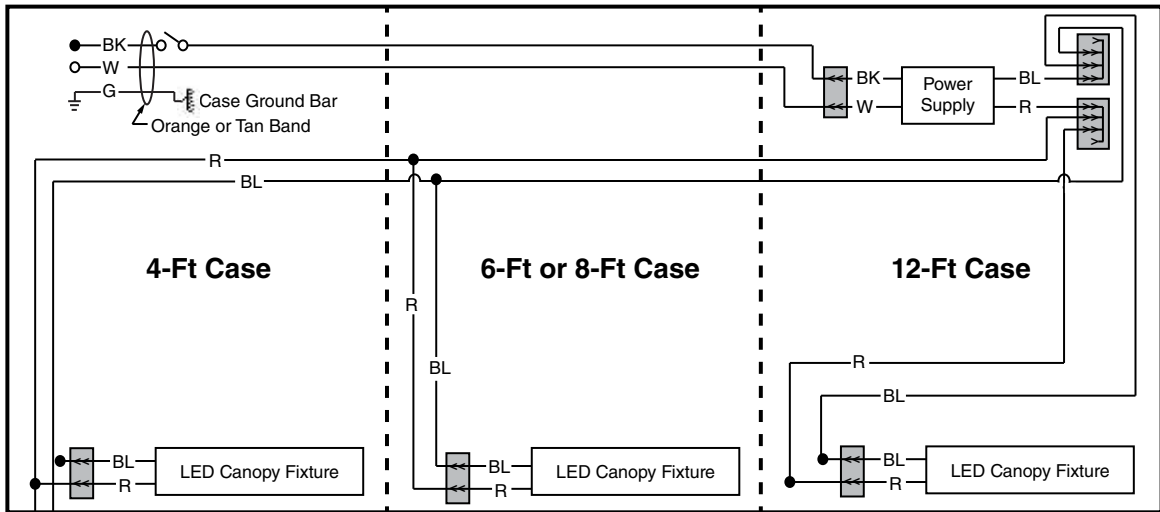

Optional Lighting - EcoShine II LED Rail - 1 Row

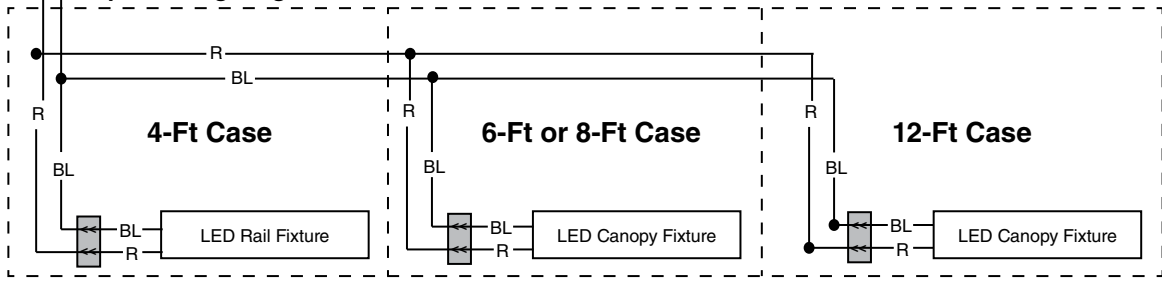

WARNING

All components must have mechanical ground, and the merchandiser must be grounded.

R = Red Y = Yellow G = Green BL = Blue BK = Black W = White
 ● = 120V POWER ○ = 120V NEUTRAL ⚡ = FIELD GROUND  = CASE GROUND

Shelf Harness and LED Light Circuits for 6 or 7 Rows of Shelves

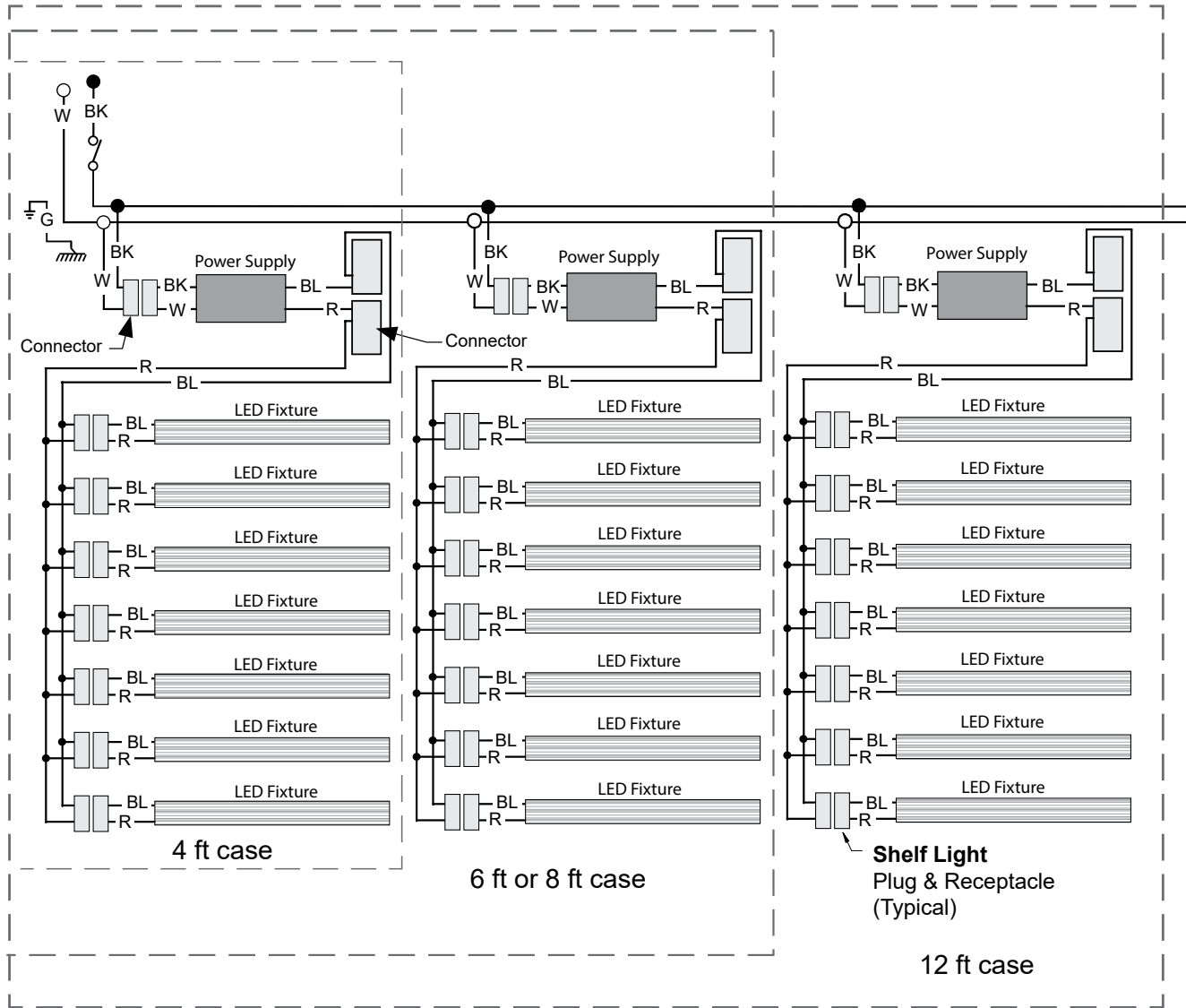

WARNING

All components must have mechanical ground, and the merchandiser must be grounded.

R = Red Y = Yellow G = Green BL = Blue BK = Black W = White
 ● = 120V POWER ○ = 120V NEUTRAL ⊥ = FIELD GROUND mmm = CASE GROUND

Estimating Refrigeration and Electrical Load (for comparison purposes only)

Case Btu

To determine Btu for a case, refer to the performance data chart on page 2. Select lit or unlit shelves, then select the type of remote refrigeration system (parallel or conventional), which will give Btu/hr/ft. Multiply this number by the length of the case to determine Btu per hour.

Case Electrical

Refer to store legend to determine number of circuits. Lighting should be specified in store legend.

Fan electrical load for a case is computed by selecting the case length and fan voltage on page 6. For example, a 12 ft case uses 3 fans. The store legend specifies fans on a 230V circuit. In this instance, fans use 1.00 Amps and the MCA is 1.20. When applied, ambient fans, anti-sweat heaters, controllers, etc. must be included in the MCA. Include lights in the MCA if lights are on same circuit.

Lights may be on a separate circuit. To estimate lighting load: select case length (12 ft), canopy lighting [standard or optional] (here 0.70 for standard), and shelf or rail lighting [maximum for which case is wired] (1.48 for six shelves); then add together [$0.48 + 1.48 = 1.96$ amps for 120V] (for 230V, multiply $1.96 * 0.52 = 1.02$).

Line Sizing — Refer to store legend.

Hussmann Line Sizing Charts are engineered for use with Hussmann refrigeration equipment.



Scan the QR code with your mobile device to access additional product information or order parts.

Parts may also be ordered at:

parts.hussmann.com

Call toll free: 1.855.487.7778

Revision History

Revision A: October 2018: Original Issue.

Revision B: August 2019. Updated parts list, lighting, CaseShieldPTM, cross section and plan view.