

MINIMUM CLEARANCE REQUIREMENTS:

ACTUAL CLEARANCE REQUIREMENTS ARE DEPENDENT UPON AUTHORITY HAVING JURISDICTION, AND MAY EXCEED DIMENSIONS SHOWN.

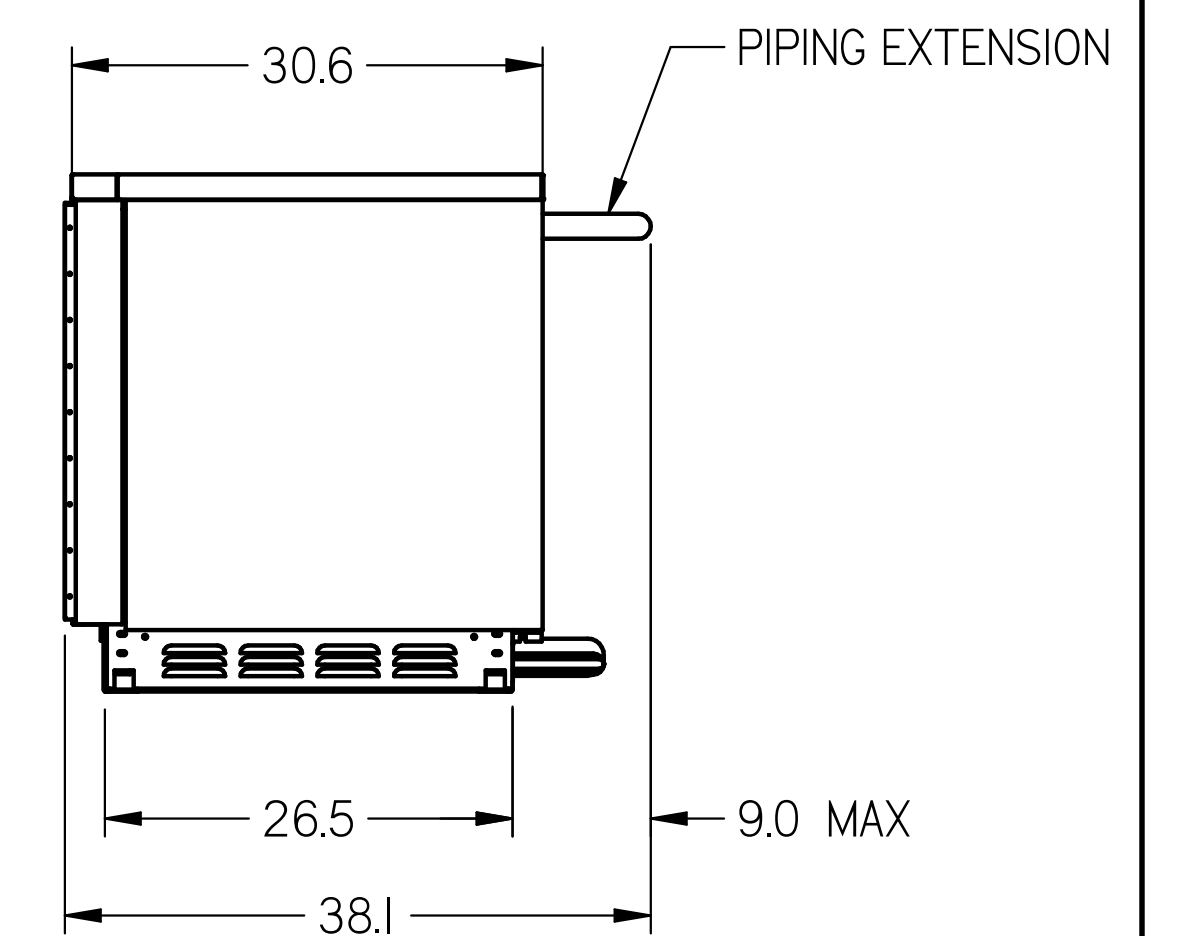
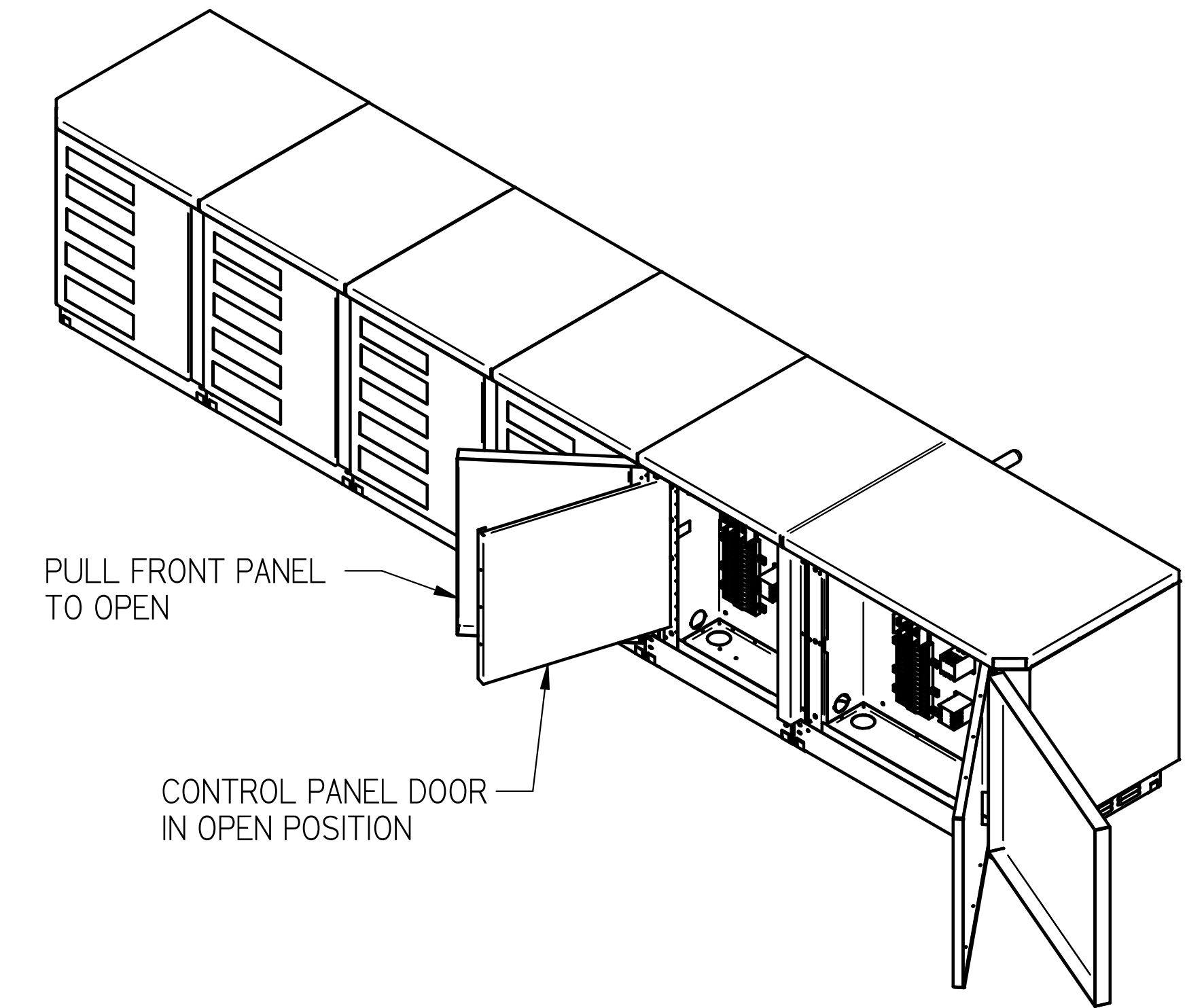
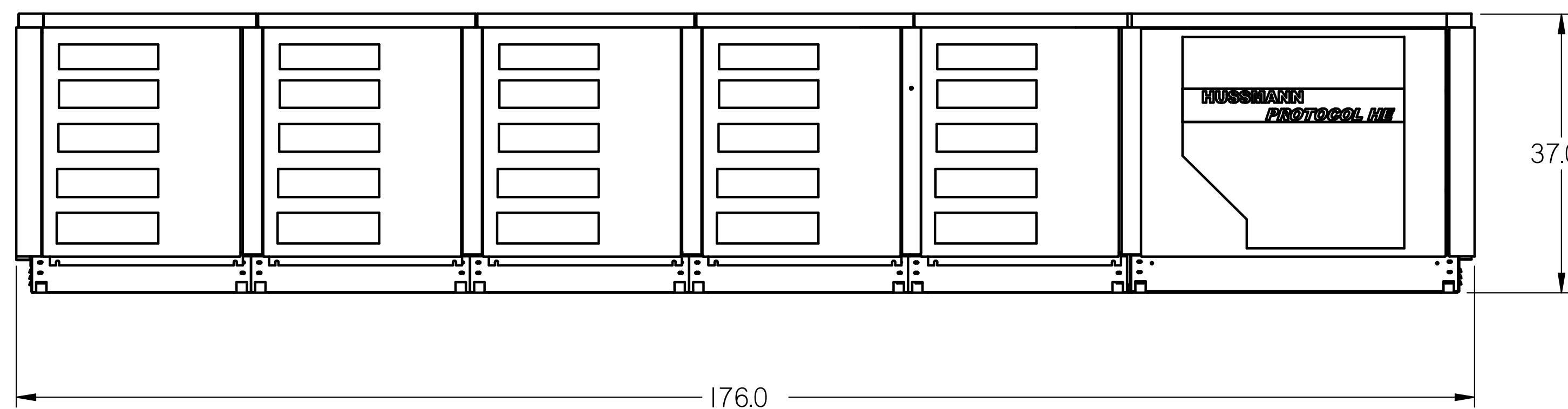
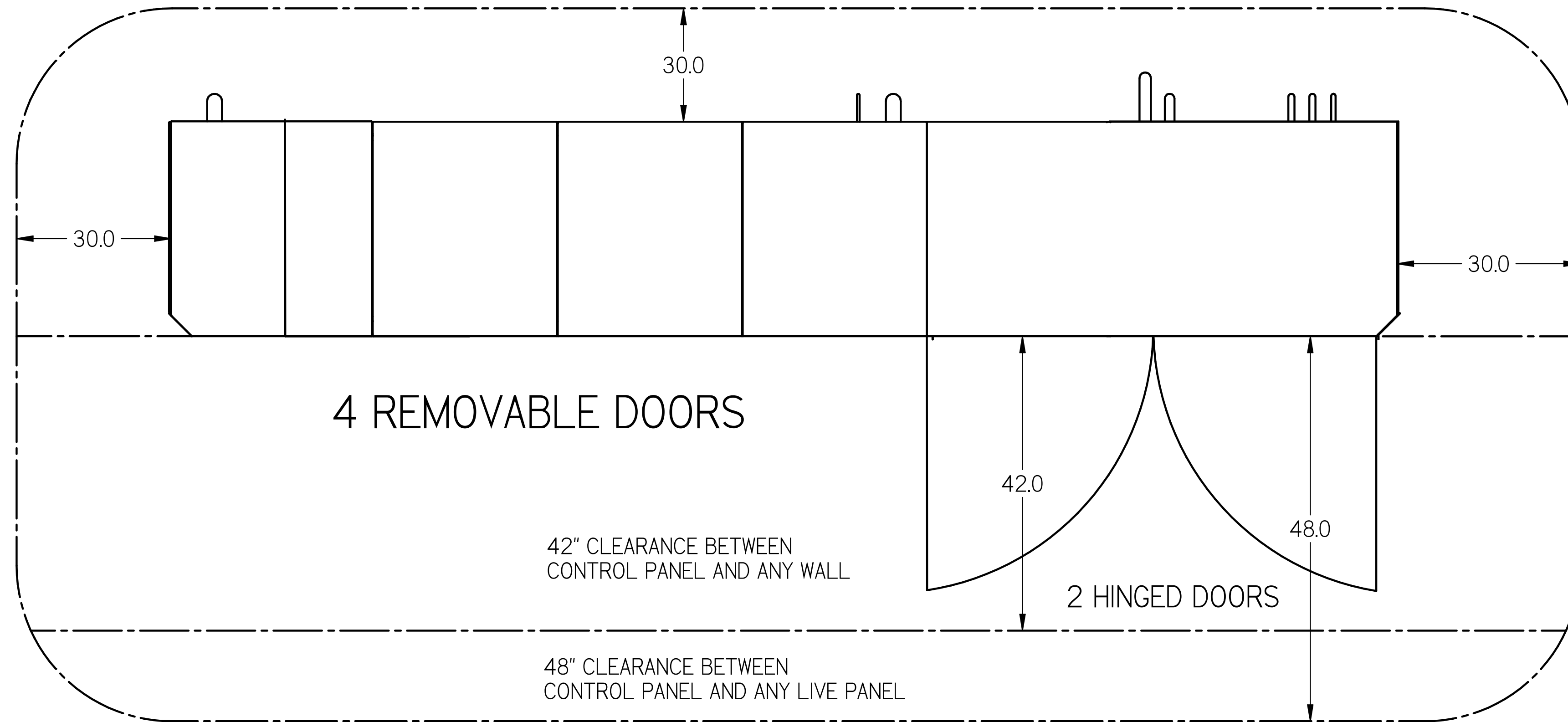

NOTES:

1. IT IS THE RESPONSIBILITY OF THE INSTALLING CONTRACTOR TO ENSURE THAT THE FINAL EQUIPMENT INSTALLATION MEETS ALL APPLICABLE CODE REQUIREMENTS.
2. ILLUSTRATION SHOWN IS FOR GENERAL REPRESENTATION ONLY. ACTUAL PRODUCT WILL VARY DEPENDENT UPON APPLICATION.
3. OVERALL DIMENSIONS: 176.0 L X 38.1. W X 37.0 H.
4. APPROXIMATE WEIGHT OF THE UNIT W/O RECEIVER = 2250 LBS
5. APPROXIMATE WEIGHT OF THE UNIT WITH RECEIVER = 2550 LBS

INFORMATION SUBJECT TO CHANGE

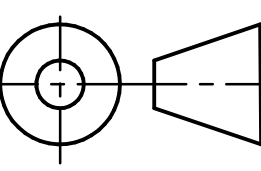
DIMENSIONS ARE IN INCHES. DATE DRAWN: 2017/09/14		HUSSMANN [®]	
 THIRD ANGLE PROJECTION		ASSM 4.1 WIDE HORIZONTAL PROTOCOL.	
		DOC PD-000000077	REV B
SHEET 1 OF 2			

SWN 1.0 SUBMITTAL SHEET SIZE D

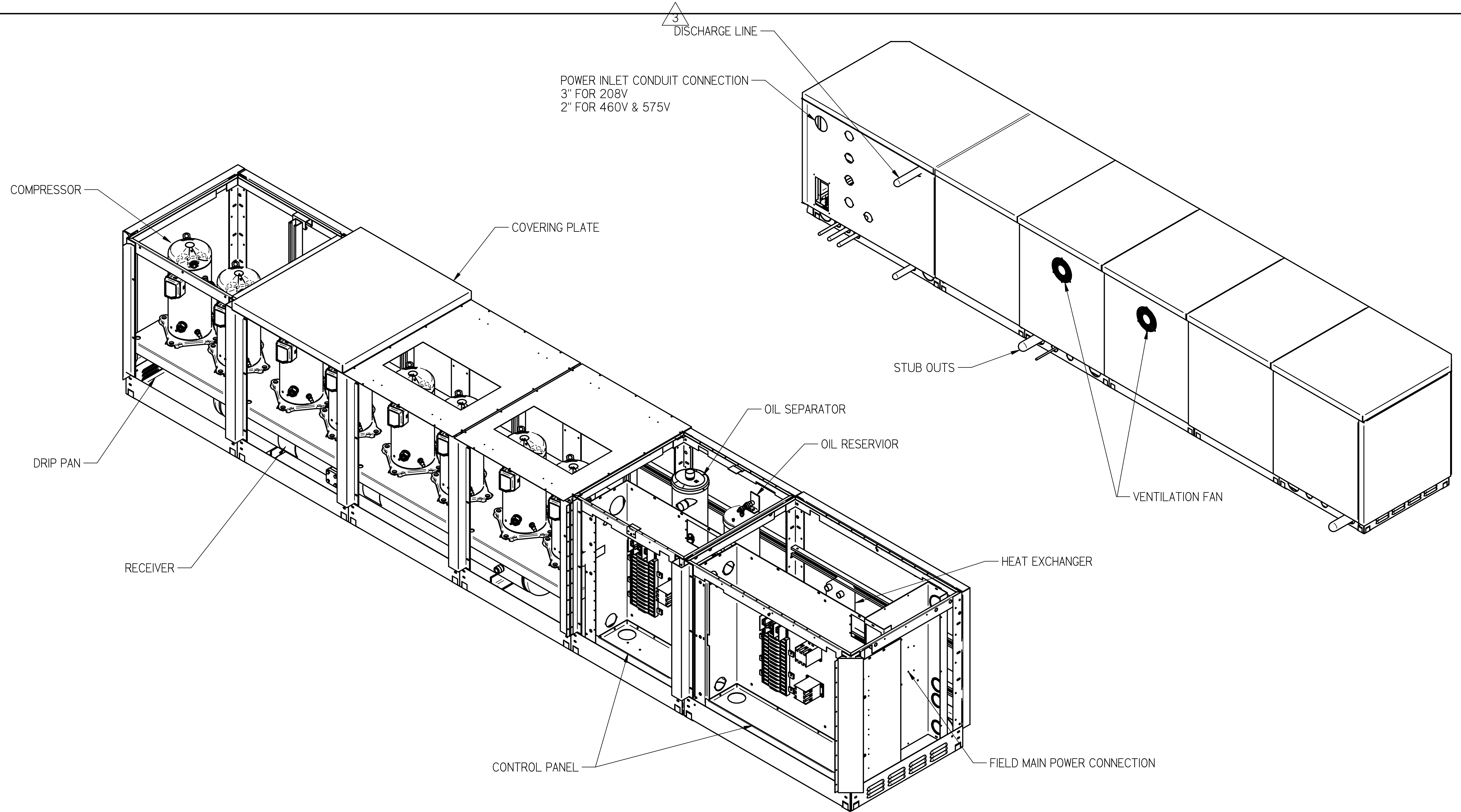

NOTES:

1. IT IS THE RESPONSIBILITY OF THE INSTALLING CONTRACTOR TO ENSURE THAT THE FINAL EQUIPMENT INSTALLATION MEETS ALL APPLICABLE CODE REQUIREMENTS.
2. ILLUSTRATION SHOWN IS FOR GENERAL REPRESENTATION ONLY. ACTUAL PRODUCT WILL VARY DEPENDENT UPON APPLICATION.
3. OVERALL DIMENSIONS: 176.0 L X 38.1. W X 37.0 H.
4. APPROXIMATE WEIGHT OF THE UNIT W/O RECEIVER = 2250 LBS
5. APPROXIMATE WEIGHT OF THE UNIT WITH RECEIVER =2550 LBS

INFORMATION SUBJECT TO CHANGE

DIMENSIONS ARE IN INCHES. DATE DRAWN: 2017/09/14		HUSSMANN [®]
THIRD ANGLE PROJECTION		
SHEET 2 OF 2		ASSM 4.1 WIDE HORIZONTAL PROTOCOL. DOC PD-000000077 REV B

SWN 1.0 SUBMITTAL SHEET SIZE D