

MINIMUM CLEARANCE REQUIREMENTS:

ACTUAL CLEARANCE REQUIREMENTS ARE DEPENDENT UPON AUTHORITY HAVING JURISDICTION AND MAY EXCEED DIMENSIONS SHOWN.

- A) 42.0" CLEARANCE BETWEEN CONTROL PANEL AND ANY WALL
- B) 48.0" CLEARANCE BETWEEN CONTROL PANEL AND ANY LIVE PANEL
- C) 30.0" CLEARANCE FOR WORK SPACE, ADJUSTMENT AND REPLACEMENT OF PARTS

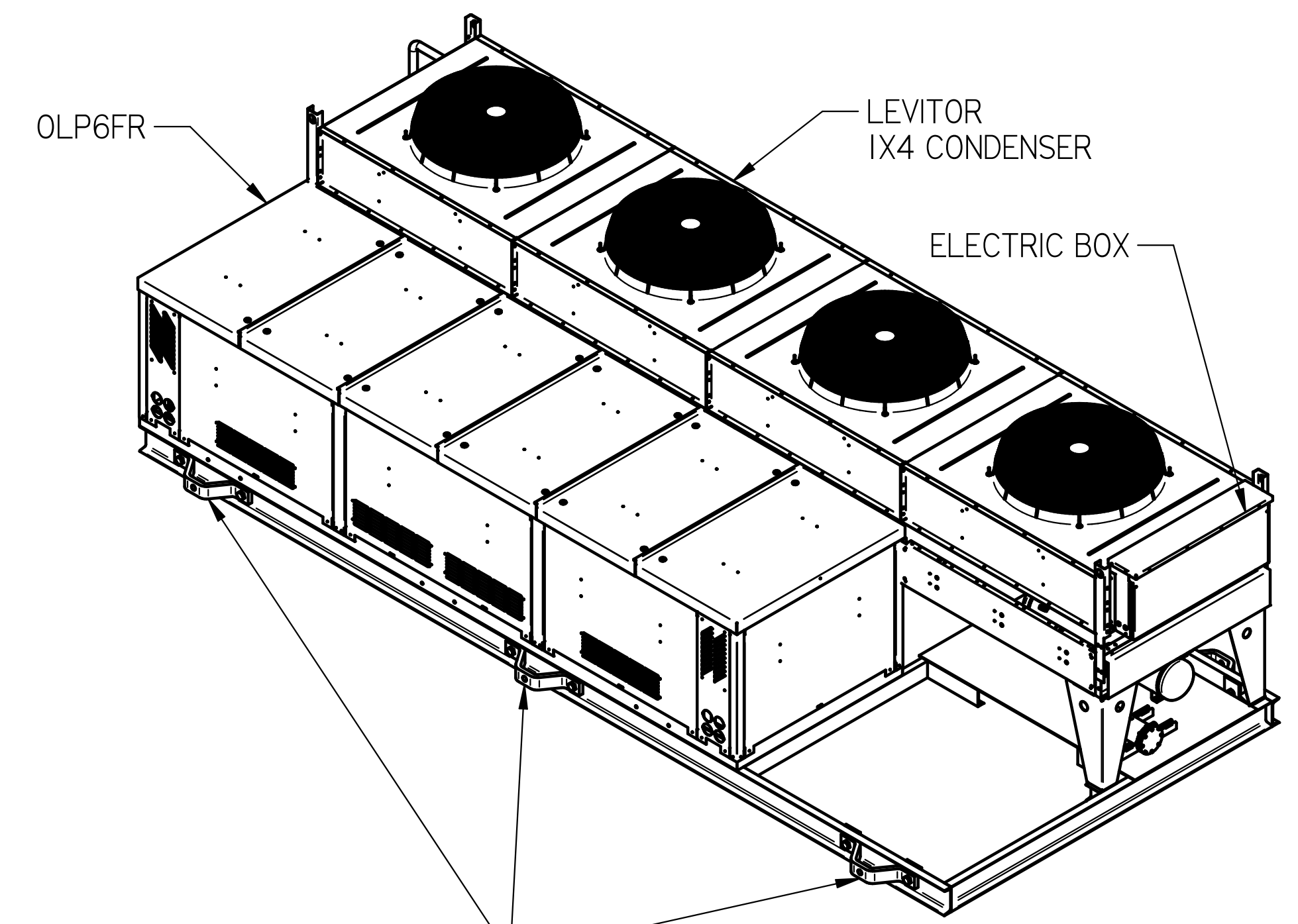
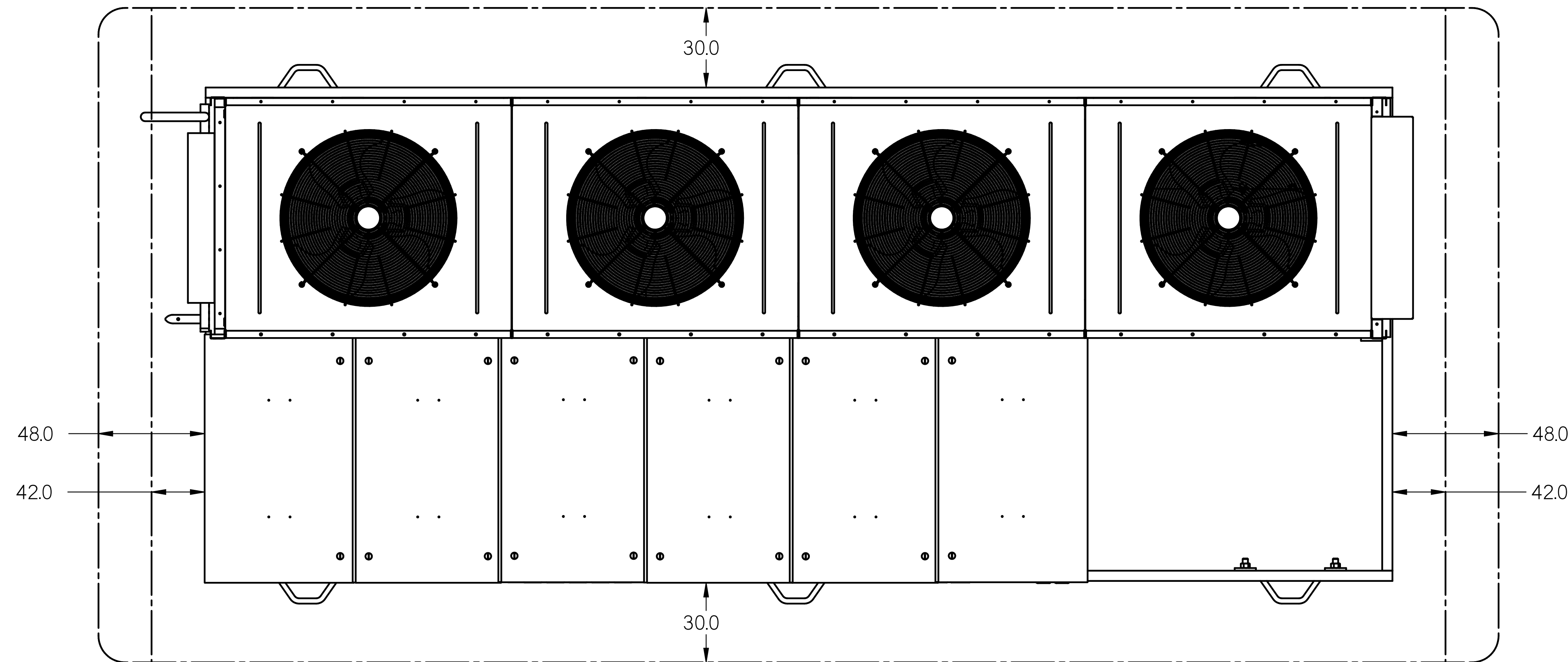

LIFTING STRP CAN BE SHIPPED LOOSE WHEN REQUIRED FOR SHIPPING PURPOSES

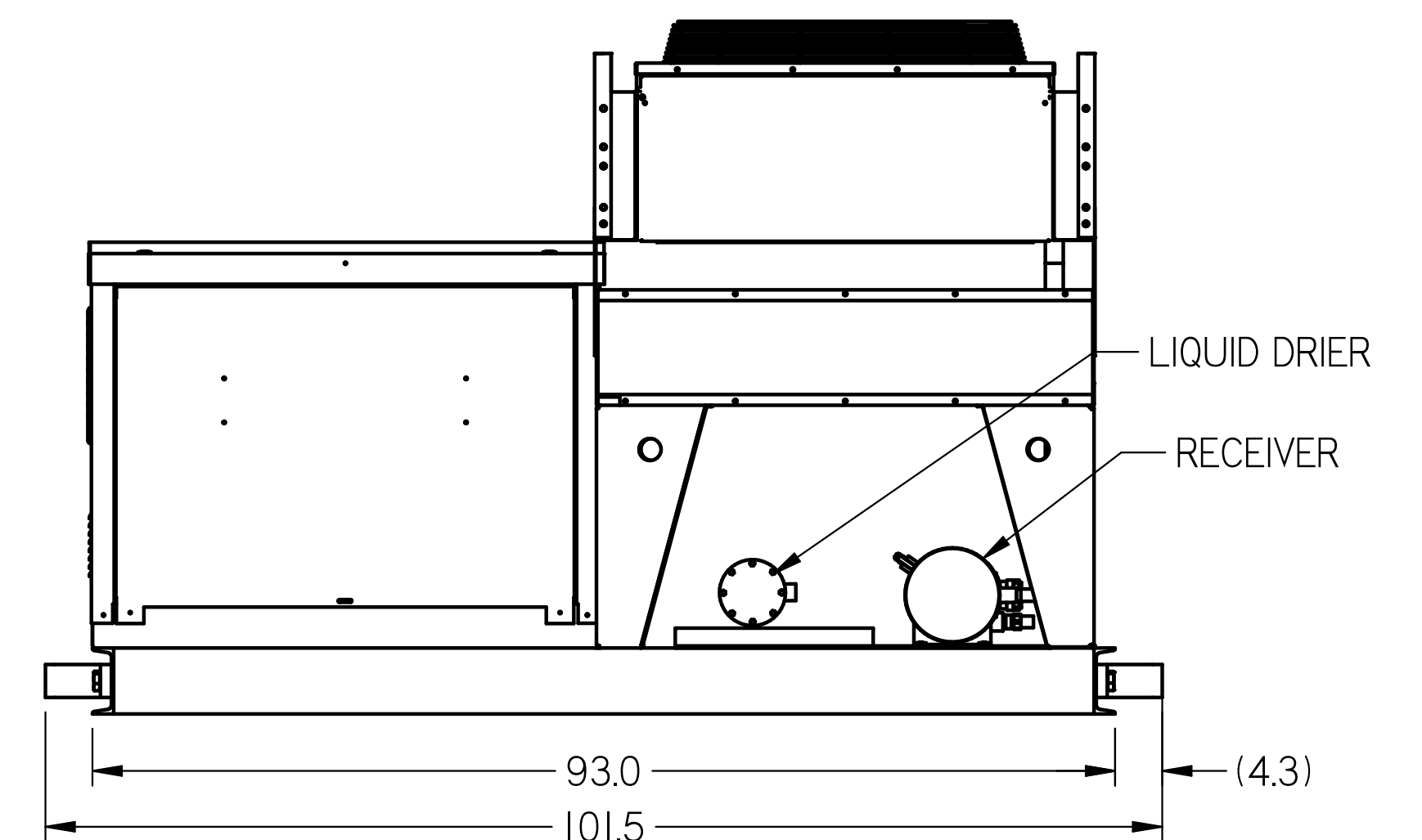
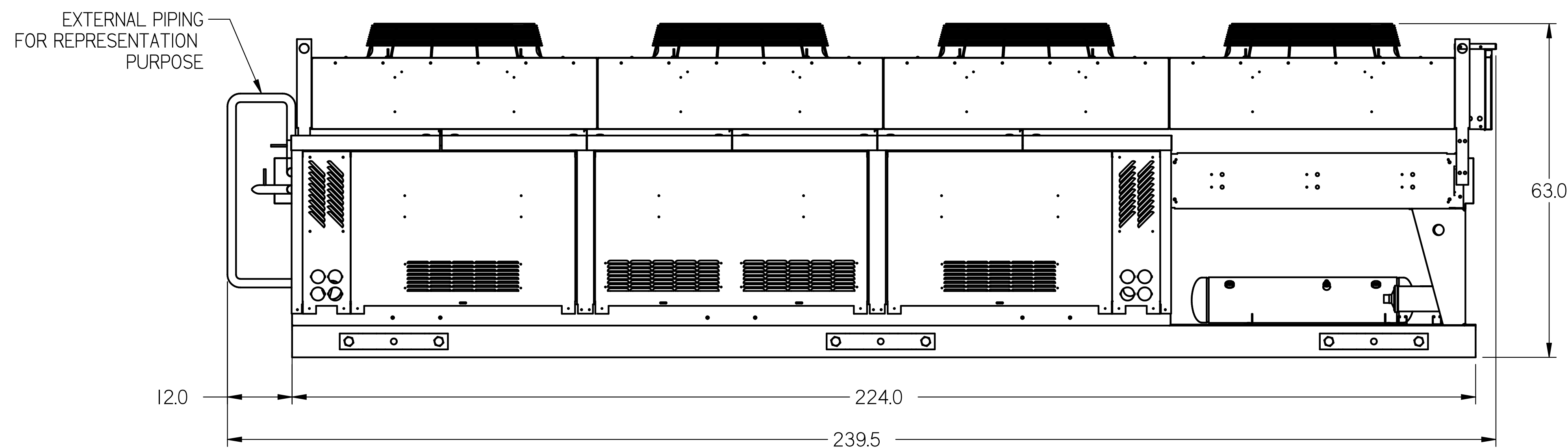

NOTES:

1. IT IS THE RESPONSIBILITY OF THE INSTALLING CONTRACTOR TO ENSURE THAT THE FINAL EQUIPMENT INSTALLATION MEETS ALL APPLICABLE CODE REQUIREMENTS.
2. ILLUSTRATION SHOWN IS FOR GENERAL REPRESENTATION ONLY. ACTUAL PRODUCT WILL VARY DEPENDENT UPON APPLICATION.
3. OVERALL DIMENSIONS: 239.5 L X 101.5 W X 63.0 T
4. APPROXIMATE WEIGHT OF THE UNIT = 4475 LBS
5. OLP: OUT DOOR LOW PROFILE, A PRODUCT OF HUSSMANN CORP.

<p>THIRD ANGLE PROJECTION</p>	<p>UNLESS OTHERWISE SPECIFIED DIMENSIONS ARE IN INCHES.</p>	<p><b>HUSSMANN</b><sup>®</sup></p>
	<p>ASSY 6 COMPR OLP IX4 FAN COND</p>	<p>PIN PD-000000100 REV A</p>
<p>SHEET 1 OF 1</p>		<p>SWN 1.0 SHEET SIZE D</p>