



REVISION HISTORY						
REV	ECN	DATE	REVISION DESCRIPTION	REV BY	CHKD BY	APPR BY
A	-	2023/02/27	PRELIMINARY	VBS	AMS	VAV

CDRH - DIMENSIONAL DETAILS - REMOTE CONDENSERS

TYPE	BASE FRAME DIMENSIONS (in) (CURB)		OVERALL DIMENSIONS (in)			DOOR OPEN DIMENSIONS (in)		OVERALL WEIGHT (LBS)
	<i>L</i>	<i>W</i>	<i>L1</i>	<i>W1</i>	<i>H1</i>	<i>L2</i>	<i>W2</i>	
CDRH X	<i>L</i>	<i>W</i>	<i>L1</i>	<i>W1</i>	<i>H1</i>	<i>L2</i>	<i>W2</i>	7300
	98	95	110	102	68	148	188	

1. MAXIMUM SHIPPING WIDTH OF UNIT, INCLUDING STUB OUT: 102.00". 
2. IN CASE OF CONDENSER MOTOR CHANGE UNIT HEIGHT AND WEIGHT WILL VARY. 
3. 20X36 RECEIVER WILL BE MOUNTED INSIDE THE UNIT, IN CASE OF RECEIVER OTHER THEN 20X36 SIZE, IT WILL BE MOUNTED UNDERNEATH THE CONDENSER. 

DO NOT SCALE. DIMENSIONS TO OUTSIDE UNLESS OTHERWISE NOTED.
PART TO BE FREE OF BURRS, SHARP EDGES, AND CORNERS

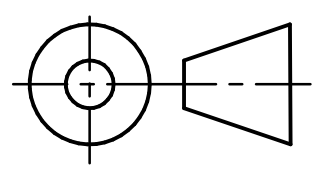
UNLESS OTHERWISE SPECIFIED DIMENSIONS ARE IN INCHES.	HUSSMANN [®]
 THIRD ANGLE PROJECTION	CDRH UNIT REMOTE CONDENSER
SHEET 1 OF 5	P/N SUBMITTAL REV A

CDRH UNIT - REMOTE CONFIGURATION

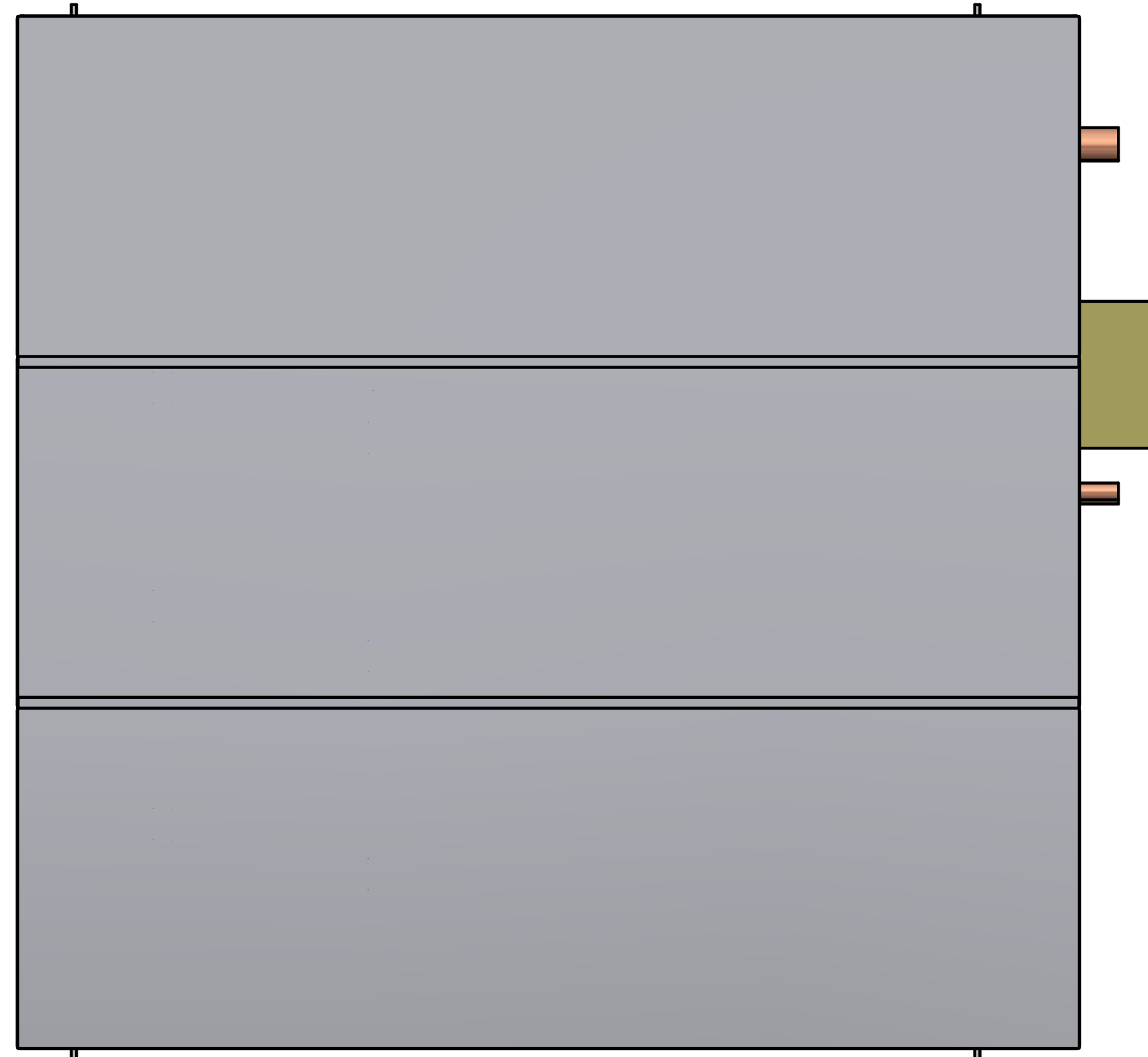
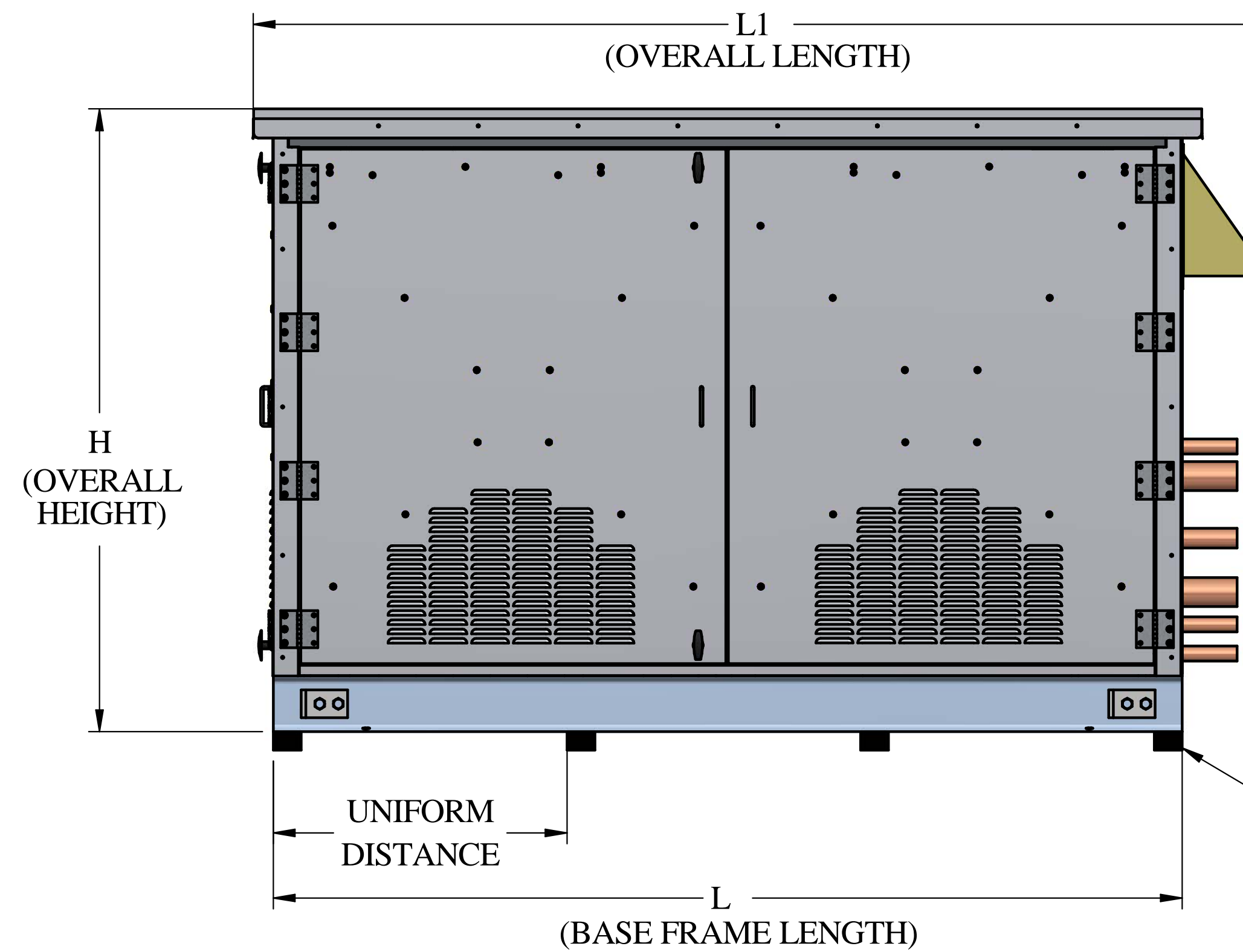
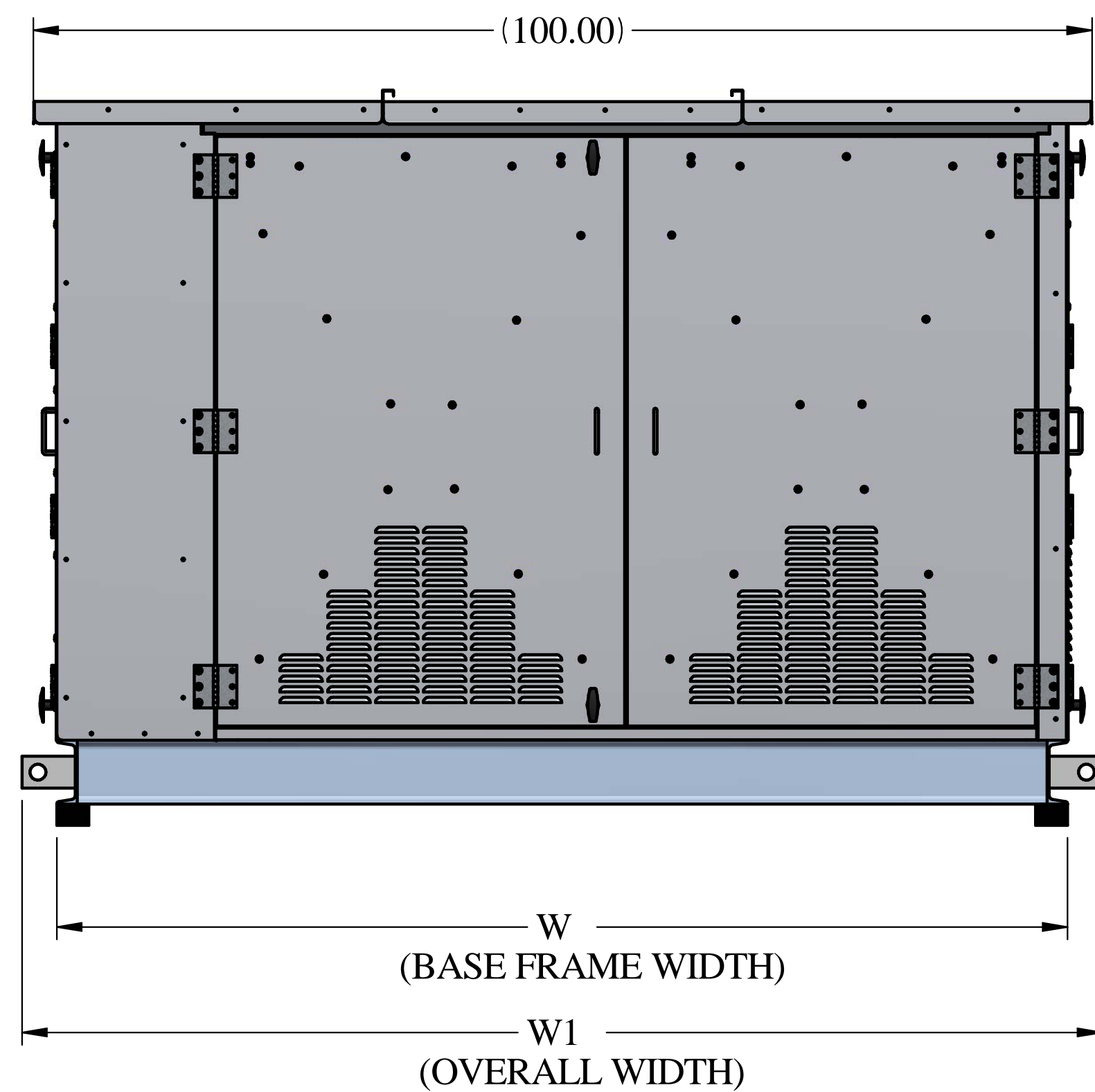

ISOLATION PADS ARE GIVEN AT 4 CORNERS AND REST OF THEM ARE UNIFORMLY DISTRIBUTED ALONG THE LENGTH OF THE FRAME

1. MAXIMUM SHIPPING WIDTH OF UNIT, INCLUDING STUB OUT: 102.00".
2. IN CASE OF CONDENSER MOTOR CHANGE UNIT HEIGHT AND WEIGHT WILL VARY.
3. 20X36 RECEIVER WILL BE MOUNTED INSIDE THE UNIT, IN CASE OF RECEIVER OTHER THEN 20X36 SIZE, IT WILL BE MOUNTED UNDERNEATH THE CONDENSER.

DO NOT SCALE. DIMENSIONS TO OUTSIDE UNLESS OTHERWISE NOTED.
PART TO BE FREE OF BURRS, SHARP EDGES, AND CORNERS

UNLESS OTHERWISE SPECIFIED DIMENSIONS ARE IN INCHES.	HUSSMANN [®]	
	CDRH UNIT REMOTE CONDENSER	
	THIRD ANGLE PROJECTION	P/N SUBMITTAL
SHEET 2 OF 5	REV A	

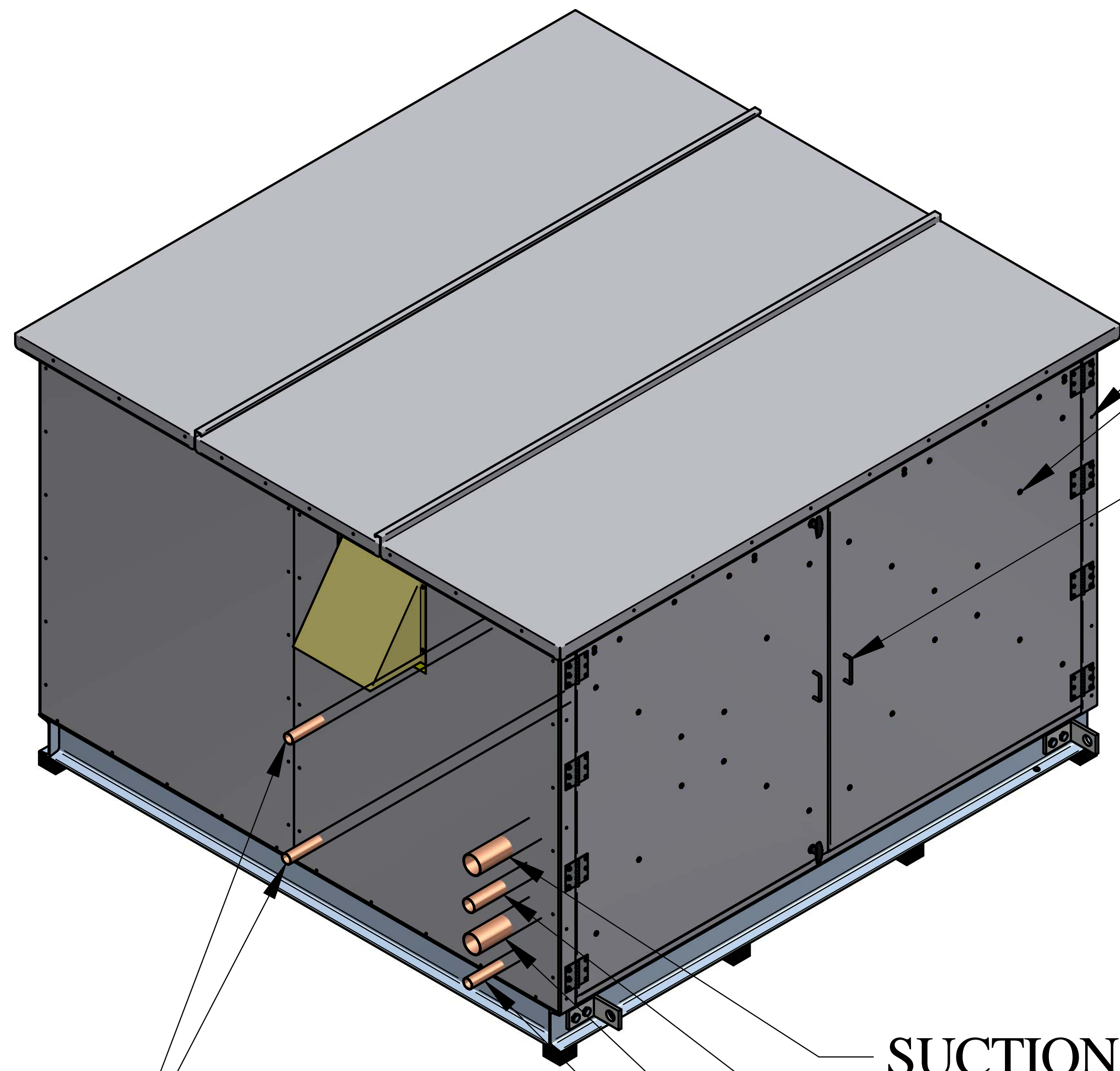

CONDENSER CONNECTIONS

REAR VIEW

SUCTION STUB
LIQUID STUB
SUCTION STUB
LIQUID STUB

MAIN ELECTRICAL POWER ENTRANCE
COMPRESSOR AND CONDENSER VFD ARE BEHIND THIS DOOR
MAIN ELECTRICAL PANEL ACCESS DOOR

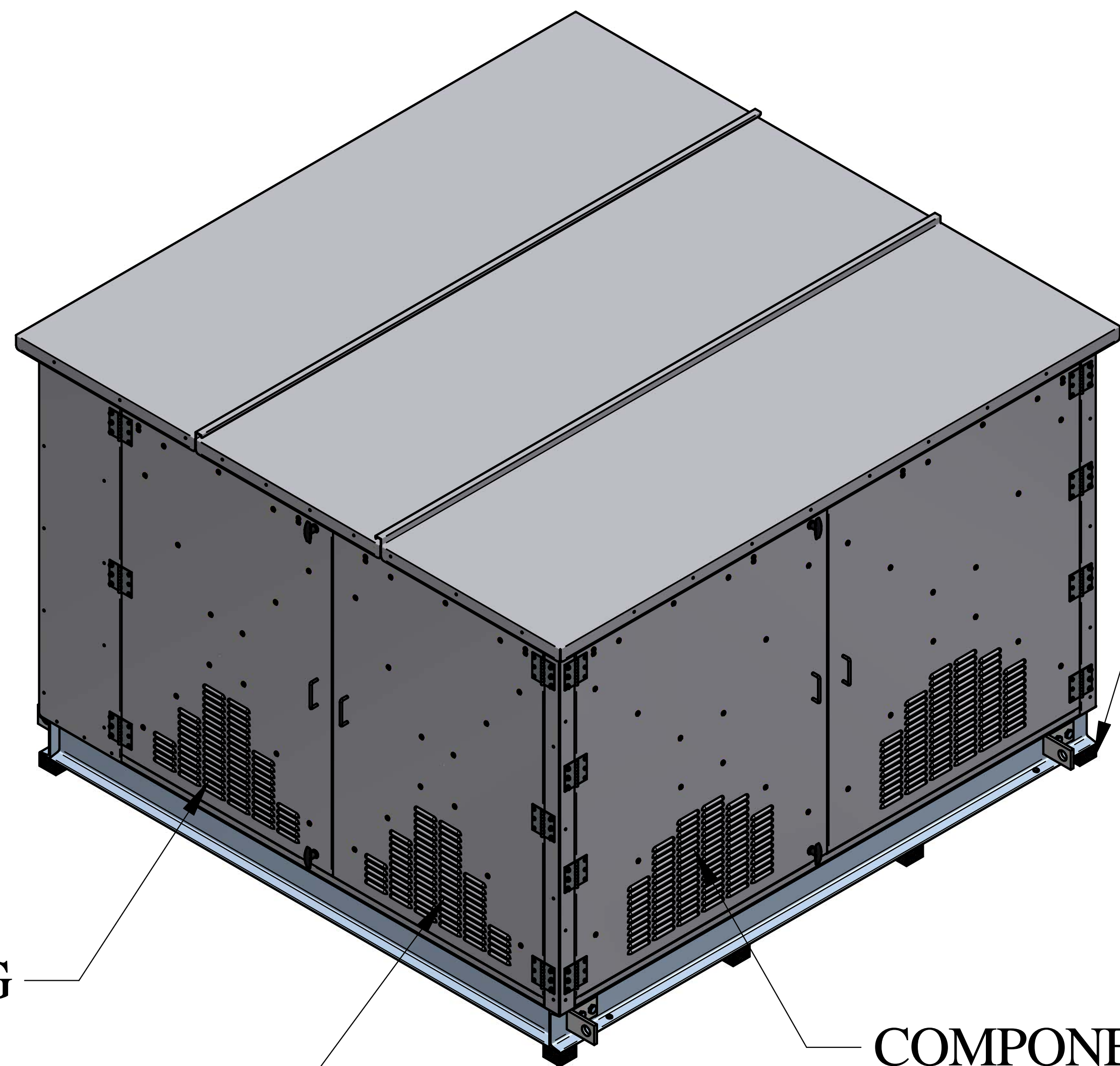

RACK HOUSING

COMPRESSOR ACCESS DOOR

FRONT VIEW

COMPONENT ACCESS DOOR

ISOLATION PADS ARE GIVEN AT 4 CORNERS AND REST OF THEM ARE UNIFORMLY DISTRIBUTED ALONG THE LENGTH OF THE FRAME

ISOLATION PAD 3X3X2", KIP PADS X QTY

1. MAXIMUM SHIPPING WIDTH OF UNIT, INCLUDING STUB OUT: 102.00".
2. IN CASE OF CONDENSER MOTOR CHANGE UNIT HEIGHT AND WEIGHT WILL VARY.
3. 20X36 RECEIVER WILL BE MOUNTED INSIDE THE UNIT, IN CASE OF RECEIVER OTHER THEN 20X36 SIZE, IT WILL BE MOUNTED UNDERNEATH THE CONDENSER.

DO NOT SCALE. DIMENSIONS TO OUTSIDE UNLESS OTHERWISE NOTED. PART TO BE FREE OF BURRS, SHARP EDGES, AND CORNERS

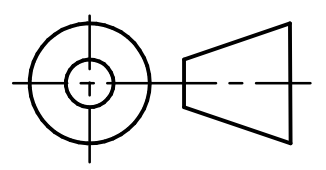
UNLESS OTHERWISE SPECIFIED DIMENSIONS ARE IN INCHES.  THIRD ANGLE PROJECTION	HUSSmann [®]	
	CDRH UNIT REMOTE CONDENSER	
SHEET 3 OF 5	P/N SUBMITTAL	REV A

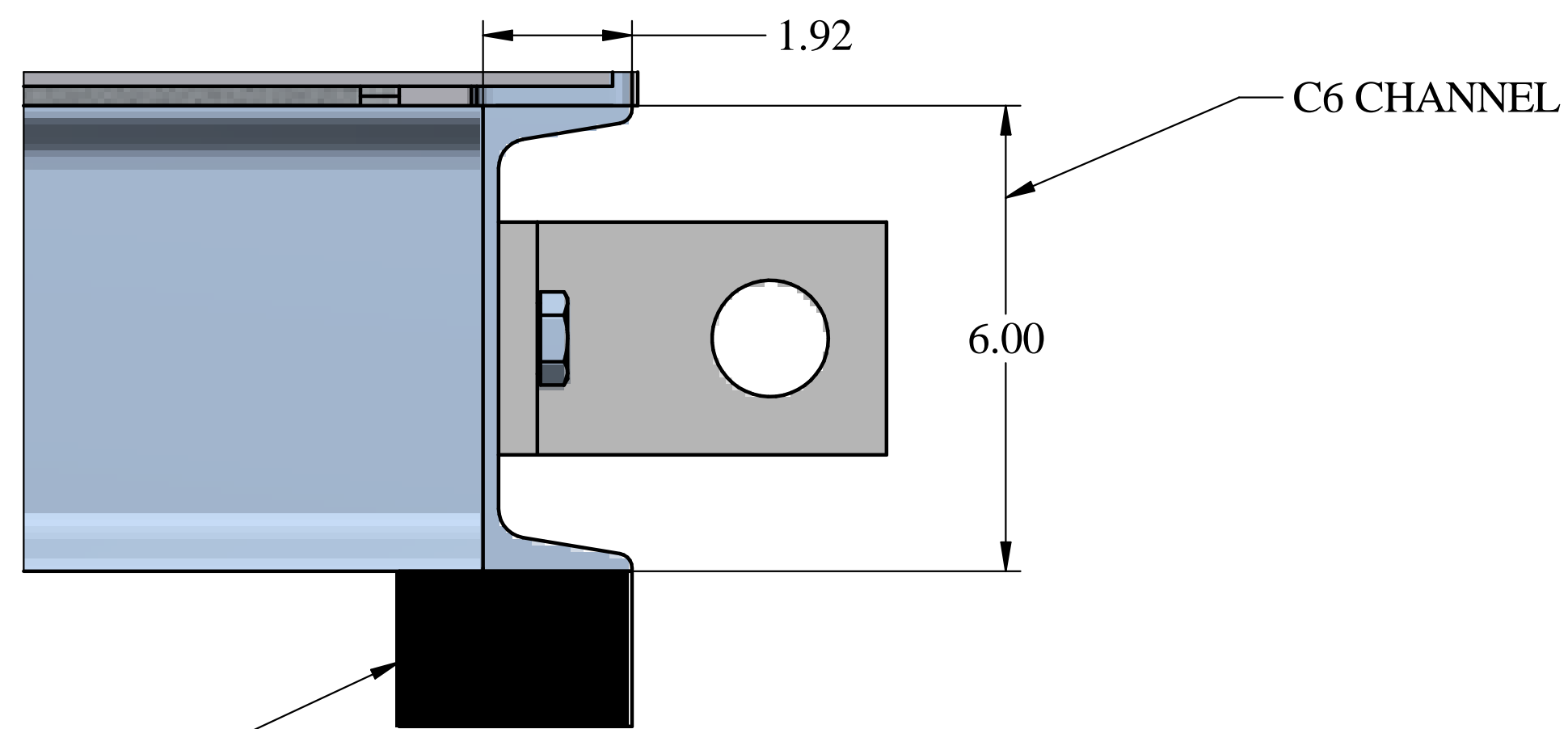
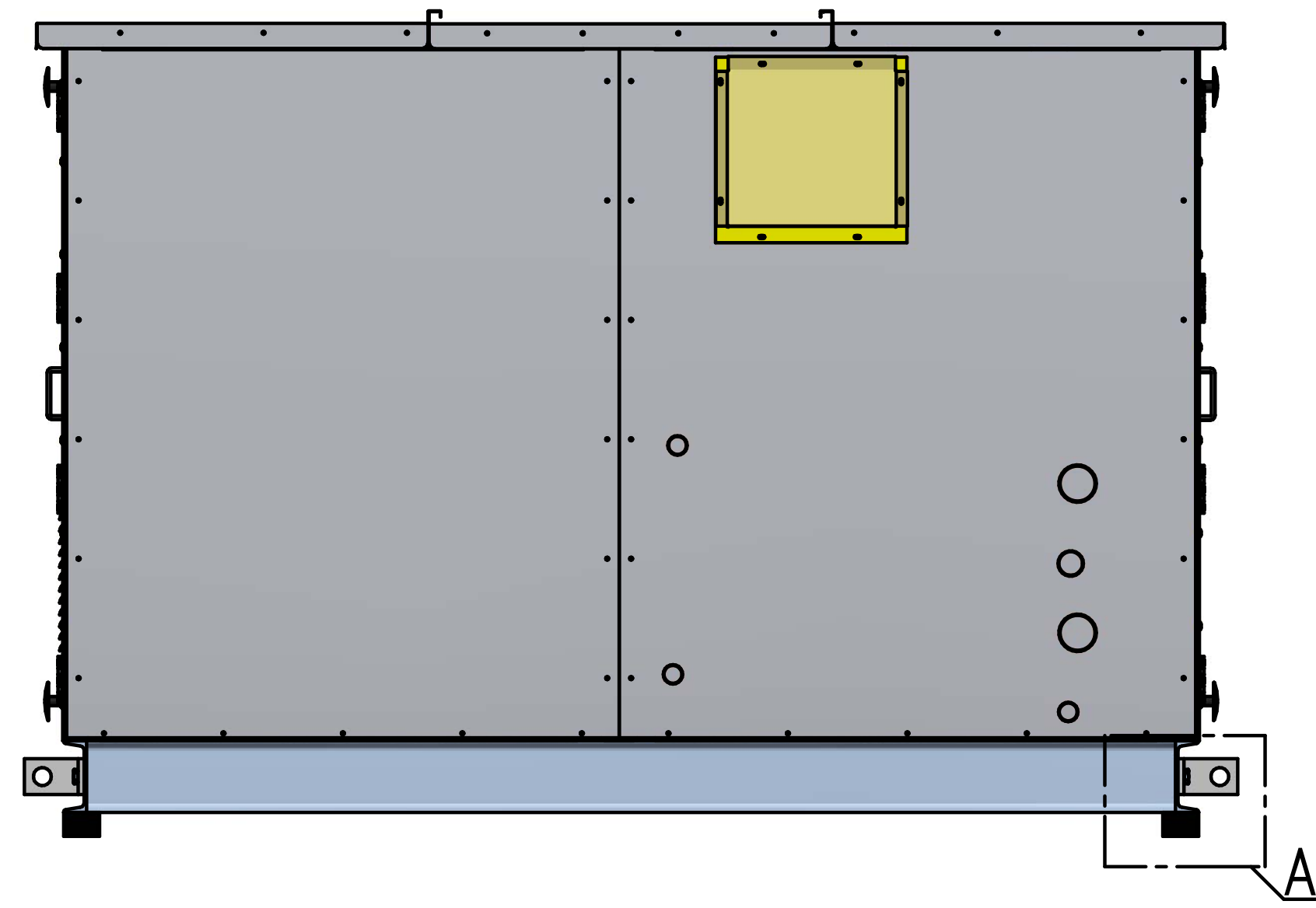

ISOLATION PAD

C6 CHANNEL

DETAIL A

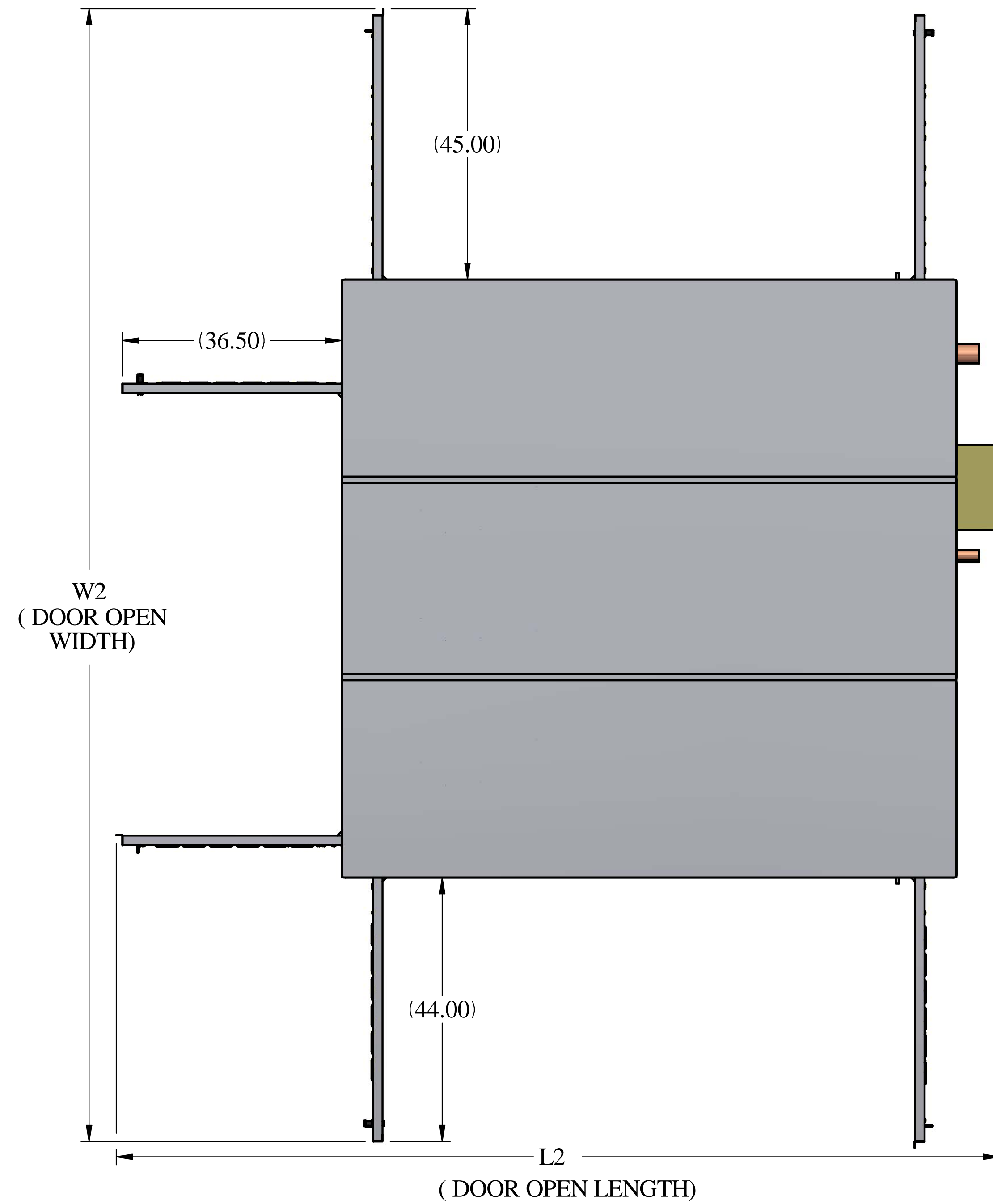

1. MAXIMUM SHIPPING WIDTH OF UNIT, INCLUDING STUB OUT: 102.00".
2. IN CASE OF CONDENSER MOTOR CHANGE UNIT HEIGHT AND WEIGHT WILL VARY.
3. 20X36 RECEIVER WILL BE MOUNTED INSIDE THE UNIT, IN CASE OF RECEIVER OTHER THEN 20X36 SIZE, IT WILL BE MOUNTED UNDERNEATH THE CONDENSER.

DO NOT SCALE. DIMENSIONS TO OUTSIDE UNLESS OTHERWISE NOTED.
PART TO BE FREE OF BURRS, SHARP EDGES, AND CORNERS

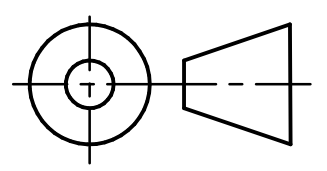
UNLESS OTHERWISE SPECIFIED DIMENSIONS ARE IN INCHES.  THIRD ANGLE PROJECTION	HUSSmann®	
	CDRH UNIT REMOTE CONDENSER	
SHEET 4 OF 5	P/N SUBMITTAL	REV A

RIGGING FOR ILLUSTRATION ONLY

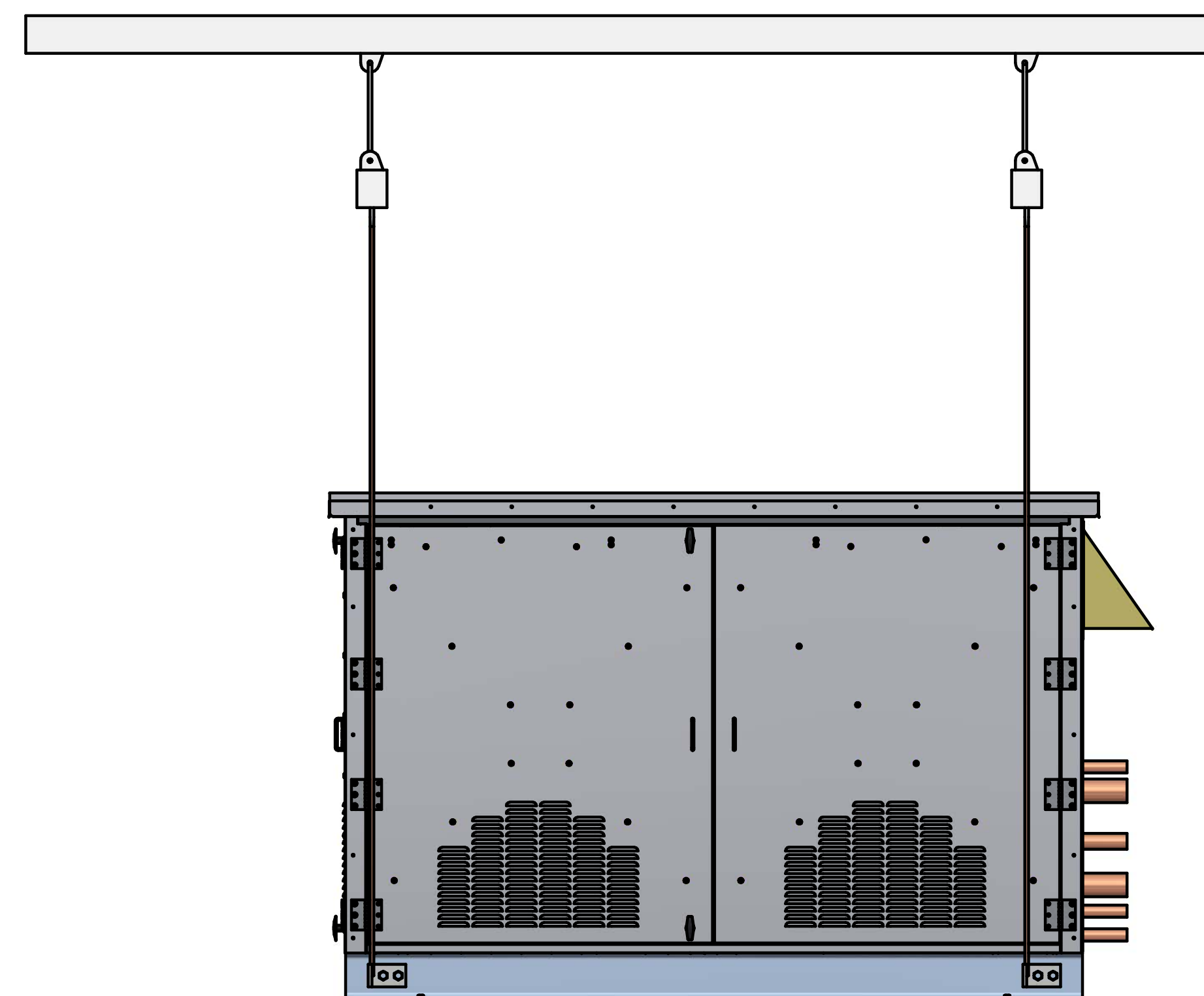
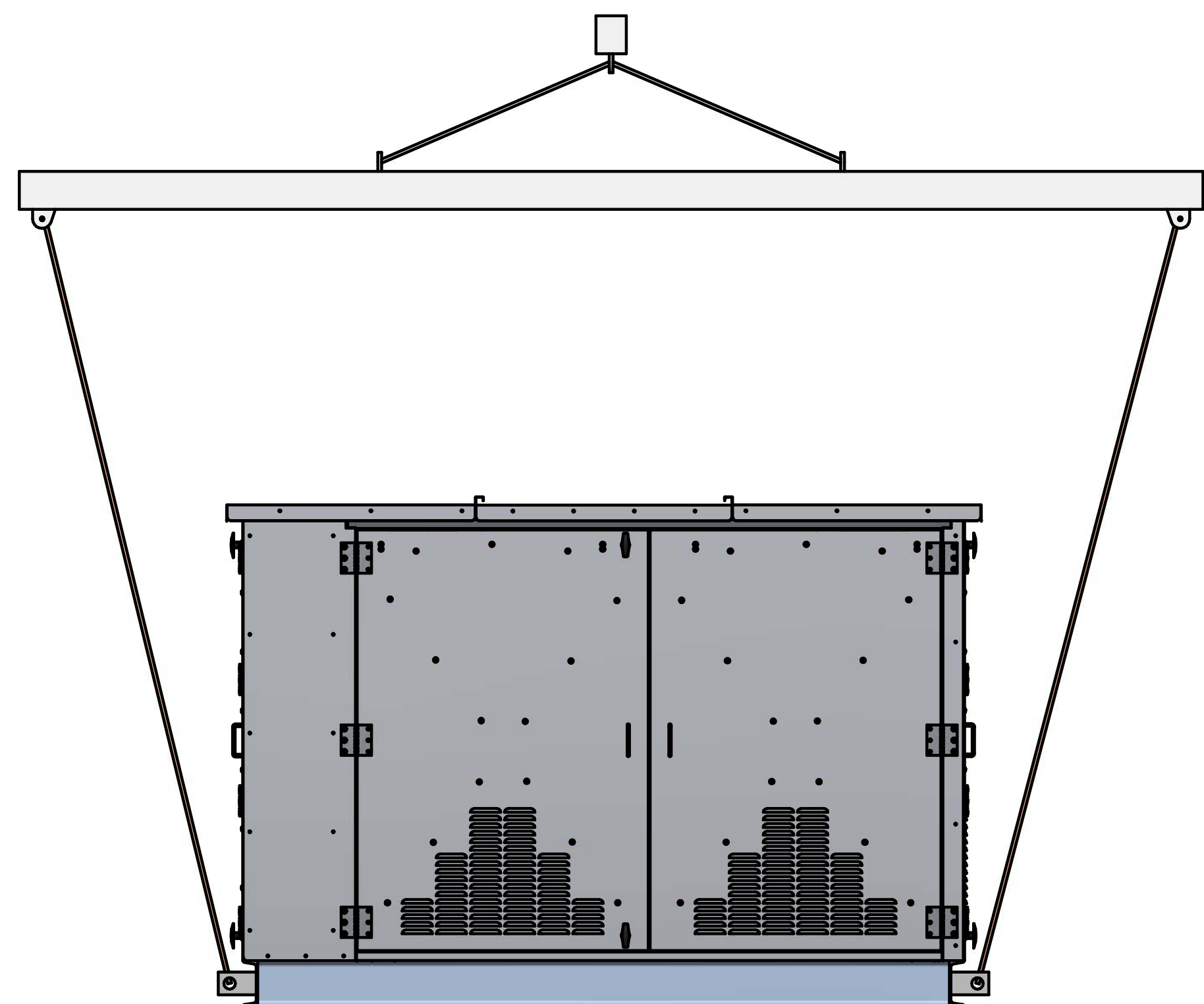
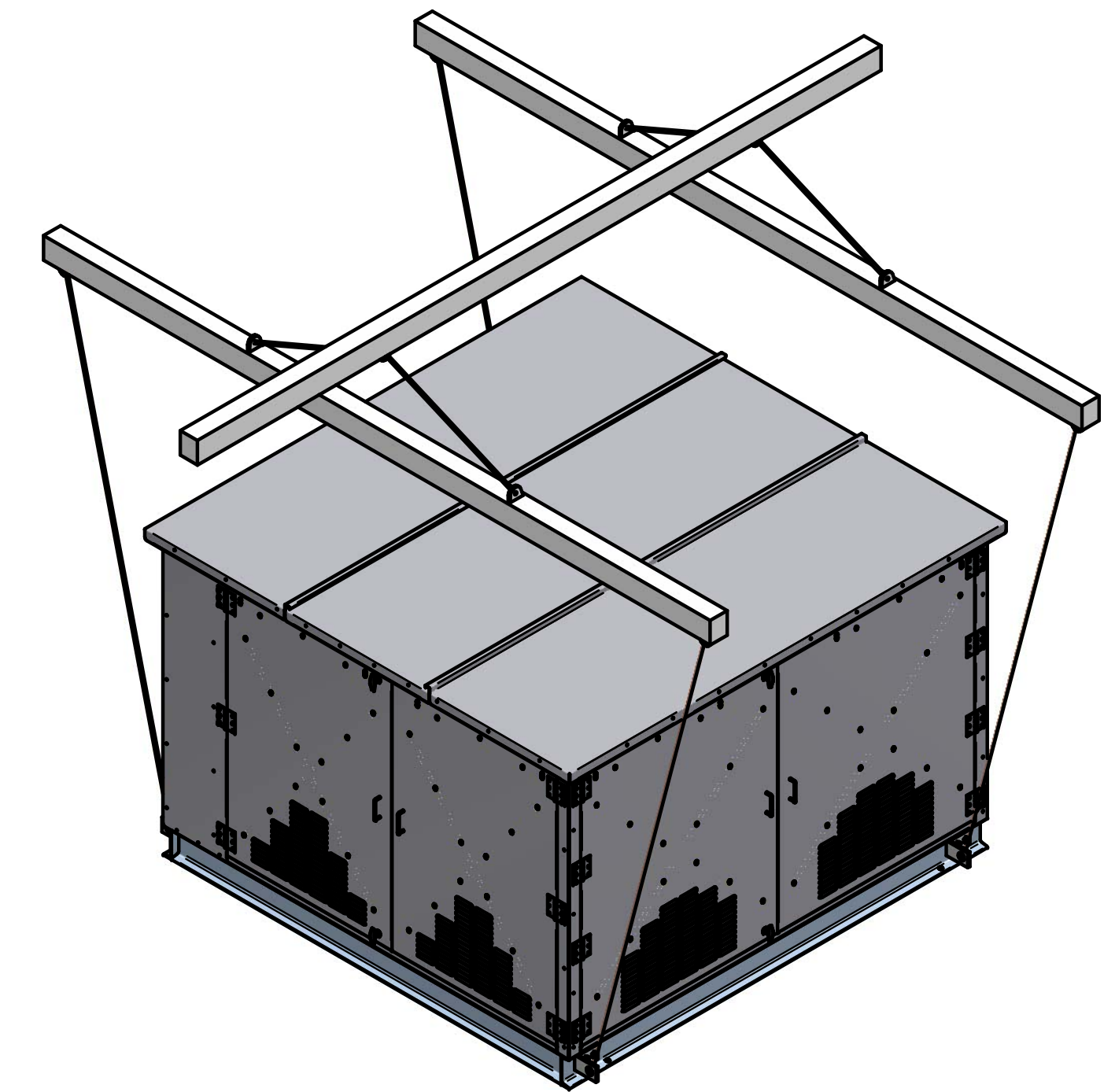

1. MAXIMUM SHIPPING WIDTH OF UNIT, INCLUDING STUB OUT: 102.00".
2. IN CASE OF CONDENSER MOTOR CHANGE UNIT HEIGHT AND WEIGHT WILL VARY.
3. 20X36 RECEIVER WILL BE MOUNTED INSIDE THE UNIT, IN CASE OF RECEIVER OTHER THEN 20X36 SIZE, IT WILL BE MOUNTED UNDERNEATH THE CONDENSER.

DO NOT SCALE. DIMENSIONS TO OUTSIDE UNLESS OTHERWISE NOTED.
PART TO BE FREE OF BURRS, SHARP EDGES, AND CORNERS

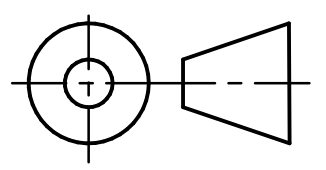
UNLESS OTHERWISE SPECIFIED DIMENSIONS ARE IN INCHES.	HUSSMANN [®]	
	CDRH UNIT REMOTE CONDENSER	
 THIRD ANGLE PROJECTION	P/N	SUBMITTAL
	SHEET 5 OF 5	
		REV A