

# **HUSSmann®**

## **INSTALLATION & SERVICE INSTRUCTIONS FOR**

### **DCCG and DCSG (-D) MODELS**

#### **Dipping and Display Case**

# **HUSSmann®**

**First Call for help (US and Canada):**

**1-800-922-1919**

**Soporte Técnico y Asistencia (México):**

**01-800-522-1900**

**For a Service Network Locator and other  
Information visit us at**

**[www.hussmann.com](http://www.hussmann.com)  
select Worldwide Locations**

**P/N OII – DCCG - DCSG  
January 2006**

## TABLE OF CONTENTS

<b>Introduction</b>	<b>3</b>
<b>Inspection</b>	<b>3</b>
<b>Specifications</b>	
<b>Construction</b>	<b>3</b>
<b>Cabinet Dimensions</b>	<b>4</b>
<b>Cabinet Capacities</b>	<b>4</b>
<b>Electrical Data</b>	<b>4</b>
<b>Installation and Start Up</b>	<b>5</b>
<b>Location</b>	<b>5</b>
<b>Power Requirements</b>	<b>5</b>
<b>Start Up Procedures</b>	<b>5</b>
<b>Operation and Maintenance</b>	
<b>Temperature Control</b>	<b>6</b>
<b>Display Lighting</b>	<b>6</b>
<b>Anti-sweat Heaters</b>	<b>6</b>
<b>Defrosting</b>	<b>6</b>
<b>Condensing Unit</b>	<b>7</b>
<b>Cleaning the Condenser</b>	<b>7</b>
<b>Cleaning Exterior</b>	<b>7</b>
<b>Cleaning Interior</b>	<b>7</b>
<b>Serial Plate Location and Refrigerant Charges</b>	<b>7</b>
<b>Temperature Control Replacement</b>	<b>7</b>
<b>Operational Data</b>	<b>8</b>
<b>Trouble Shooting Chart</b>	<b>8 - 9</b>

## TABLE OF CONTENTS CON'T

### Dipping Using Guide

<b>Loading</b>	<b>10</b>
<b>Storage</b>	<b>10</b>
<b>Lids</b>	<b>10</b>
<b>Temperature Control</b>	<b>10 - 11</b>
<b>Load Limits</b>	<b>11</b>
<b>Dipping</b>	<b>11</b>

<b>Maintenance</b>	<b>11</b>
<b>Warranty and Parts Information</b>	<b>12 - 13</b>

## **INTRODUCTION, INSPECTION, SPECIFICATIONS INSTALLATION and START UP**

### **INTRODUCTION** –

The DCSG/DCCG-4 8, 12, and 16 are specifically designed for dipping/display of bulk ice cream, sherbet, or frozen yogurt. Wide glass front and one-piece molded lids provide an unobstructed view of the product for impulse merchandising. Optional items include easy to use can holder trays and dipper wells. The –D models on -8, -12 and -16 include the labor saving storage doors feature.

### **INSPECTION** –

Upon receipt of the cabinet, carefully examine the crating for damage. If damage is found, make a note on the delivery ticket before signing. Carefully remove shipping crate and examine the cabinet for “concealed” damage. If damage is found contact the delivering carrier immediately and have his agent prepare an inspection report for the purpose of filing a claim. *This is your responsibility.*

## **SPECIFICATIONS**

### **CONSTRUCTION** –

The base is an all welded assembly of heavy duty steel to provide a strong frame on which the rest of the cabinet is built.

The shell is formed from heavy gauge steel, welded together as an assembly, and then welded to the base for strength and

durability. The entire assembly is then chemically treated and finished with baked-on powder paint.

The liner is an all welded assembly of electro zinc steel. Copper evaporator tubing is fastened to the liner and applying a conductive material on both top and bottom of the tubing further enhances maximum heat transfer. The liner is also chemically treated and painted with baked-on powder paint.

All models incorporate a slide-out condensing unit for easy access to all components.

**CABINET DIMENSIONS –**

<i>Cabinet Model</i>	<i>Dimensions (inches)</i>				<i>Height Outside</i>	<i>Ship Wt.</i>
	<i>Length Outside</i>	<i>Inside</i>	<i>Width</i>			
<i>DCSG/DCCG</i>			<i>Outside *</i>	<i>Inside</i>		
<i>-4</i>	<i>25 3/8</i>	<i>21</i>	<i>25 13/16</i>	<i>21 1/2</i>	<i>51 1/4</i>	<i>260</i>
<i>-8</i>	<i>47 7/16</i>	<i>43 1/8</i>	<i>25 13/16</i>	<i>21 1/2</i>	<i>51 1/4</i>	<i>405</i>
<i>-12</i>	<i>67 5/16</i>	<i>63</i>	<i>25 13/16</i>	<i>21 1/2</i>	<i>51 1/4</i>	<i>515</i>
<i>-16</i>	<i>87 7/16</i>	<i>83 1/8</i>	<i>25 13/16</i>	<i>21 1/2</i>	<i>51 1/4</i>	<i>625</i>

*\* -D models (with doors) outside width = 27 9/16*

**CABINET CAPACITIES –**

<i>Cabinet Model</i>	<i>Cu. Ft.</i>	<i>Capacity (9 1/2 dia. 3 gal cans)</i>		<i># of lids</i>
		<i>Upper Display</i>	<i>Lower Display</i>	
<i>-4</i>	<i>3.3</i>	<i>4</i>	<i>-</i>	<i>1</i>
<i>-8</i>	<i>8.9</i>	<i>8</i>	<i>4</i>	<i>1</i>
<i>-12</i>	<i>14.5</i>	<i>12</i>	<i>8</i>	<i>2</i>
<i>-16</i>	<i>20.2</i>	<i>16</i>	<i>12</i>	<i>2</i>

*(Capacities of –D models are the same as models without doors)*

**ELECTRICAL DATA**

<i>Cabinet Model</i>	<i>Volts</i>	<i>HP</i>	<i>Compressor</i>		<i>Cabinet *</i>	
			<i>L.R. Amps</i>	<i>F.L. Amps</i>	<i>Nominal Run Amps</i>	<i>Fuse Amps</i>
<i>-4</i>	<i>115</i>	<i>1/3</i>	<i>33.0</i>	<i>6.4</i>	<i>6.9</i>	<i>15</i>
<i>-8</i>	<i>115</i>	<i>1/2</i>	<i>58.0</i>	<i>8.6</i>	<i>9.5</i>	<i>15</i>
<i>-12</i>	<i>115</i>	<i>1/2</i>	<i>45.0</i>	<i>7.8</i>	<i>9.9</i>	<i>15</i>
<i>-16</i>	<i>115</i>	<i>3/4</i>	<i>59.8</i>	<i>10.2</i>	<i>10.5</i>	<i>15</i>

*(electrical data of –D models are the same as standard models)*

*\* Includes main top heaters and condenser fan motors*

**Due to compressor change from semi-hermetic to hermetic these are the value changes**

<i>-8 (*hermetic)</i>	<i>115</i>	<i>1/2</i>	<i>51.0</i>	<i>.9</i>	<i>8.4</i>	<i>15</i>
<i>-12 (*hermetic)</i>	<i>115</i>	<i>1/2</i>	<i>87.0</i>	<i>7.9</i>	<i>12.0</i>	<i>15</i>

**\* effective Aug. 2002 the DCCG/DCSG-8 compressor changed from a semi-hermetic HATB-005E-IAA to hermetic T2155GK.**

**\* effective Nov. 2003 the DCCG/DCSG-12 compressor changed from a semi-hermetic KAGB-0050-IAA to hermetic J2212GK Aspera**

## **INSTALLATION and START UP**

### **LOCATION** –

The location of your cabinet is important. Make sure your selected location is **NOT** in any of the following areas as it could seriously affect the operation.

- Not in direct sunlight.
- Not in the air path of heat or air conditioning ducts.
- Not at an exit or entrance affected by extreme temperature change.

Allow 2 feet of clearance at the rear of the case to allow adequate air movement across the condenser for proper refrigeration system performance, do not obstruct the grille at the rear intake and discharge. If desired, the blank off panel behind the front (customer side) louvered panel – may be removed for rear air intake and front air discharge, but then insure 2 feet of unobstructed clearance is left at the case front.

Level case front to back and end to end, shimming where necessary upon installation to assure proper operating drains, and refrigeration system.

### **POWER REQUIREMENTS** –

The DC models are equipped with a three-wire grounded service core for your protection. The cabinets are designed to operate on 115V single-phase 60hz current. A separate circuit is recommended to prevent product loss due to overloading or malfunction of other

equipment on the same circuit. Use a time delay fuse or circuit breaker. The supply circuit must be properly grounded and conform to National and Local Electrical Codes. Voltage, as measured at the compressor terminals during operation, must not vary more than 5% from cabinet serial plate rating. If a low voltage condition exists, contact your electrician or power company.

A wiring diagram is provided on the condenser shroud for each unit.

A power (ON-OFF) switch is provided on each model. The switch is accessible through a hole provided in the rear (operator side) access panel

### **START UP PROCEDURE** -

- Cut the band which holds the compressor in place during shipment.
- Make sure fan turns freely. Check for any connections or parts that might have loosened during shipment.
- Start cabinet, and allow temperature to pull down to normal level before loading product.

## OPERATION AND MAINTENANCE SERVICING DATA AND PROCEDURES

### OPERATION and MAINTENANCE

#### TEMPERATURE CONTROL –

The thermostat, which senses the cold wall temperature, is located at the lower rear right corner of the cabinet through the access panel. It has been pre-set at the factory to maintain product temperatures between +10° and +4°. The thermostat is adjustable. If other than normal temperatures are required, adjust the control by turning the knob clockwise for colder and counter-clockwise for warmer temperatures.

#### DISPLAY LIGHTING –

All models are equipped with fluorescent light fixtures installed in the canopy. An ON-OFF switch is located in the right service side of the canopy and is so labeled.

#### ANTI-SWEAT HEATERS –

A resistance heater is installed in the perimeter of the base frame of the canopy to prevent condensation. Continuity of the heater circuit maybe checked at the splice located inside the ballast enclosure in the compressor compartment.

*Should the heater fail it may be replaced  
by:*

- Remove screws holding aluminum top to cabinet.

- Raise top and canopy as an assembly and place wood spacers between top and cabinet.
- Remove heater from under base frame.
- Disconnect spade terminal splices and remove.
- Reassemble reverse order – resistance heater wire must be taped back into position

#### DEFROSTING –

It must be recognized that accumulation of frost on the cabinet walls does impair refrigeration. Daily scraping of the interior walls with a plastic scraper will extend the length of time between complete defrosting.

Most installations will require a complete defrosting every seven to ten days. Usually the best time to defrost is at the close of business so the cabinet will be regulated for the start of the next business day.

The ice cream should be removed from the cabinet and placed in a walk-in or storage freezer during the defrosting operation. A power switch for turning the case off for defrosting is located through the access panel.

Defrosting may be accomplished with the aid of a hair dryer, plastic scraper or by merely letting the cabinet remain open until the walls are cleared. Care should

be taken not to puncture the interior walls or remove paint from the walls during this procedure.

Be sure to disconnect power from the cabinet prior to starting defrost operation. After the cabinet is completely defrosted, wash thoroughly, remove defrost water (Husmann dipping cases are provided with an outside drain located on the operator's side of the case base to assist you in this operation), wipe the interior dry, and turn the power back on.

Be sure to allow the cabinet to cool down to its operating temperature before reloading.

#### **CONDENSING UNIT –**

The condensing unit is mounted on a slideout base, accessible by removing the rear serving side access panel. The condenser is of the baretube design. The condenser fan motor draws the air through the rear access panel, across the compressor and discharges back out the rear access panel unless the case has been Field converted to front air discharge as previously discussed in the Location section of this manual. *For this reason, if the case is installed in a counter, provisions must be made for the release of the discharge air.*

#### **CLEANING THE CONDENSER –**

To clean condenser, a soft, nylon brush should be used to loosen dirt and lint. Then vacuum up the dirt or blow condenser out with a high-pressure gas such as nitrogen. Never use a wire brush to clean condenser tubes.

#### **CLEANING EXTERIOR / INTERIOR –**

When cleaning the exterior of the cabinet use a soft cloth or sponge with water and mild detergent. Rinse and wipe dry.

For cleaning the interior of the product compartment, a built-in drain has been provided with a standard hose fitting located at the front of the cabinet in the base area. Disconnect the electrical power and allow cabinet to warm to above freezing temperature. Use a soft cloth or sponge with a mild detergent to wash the interior. Wipe dry before restarting the cabinet. Allow the cabinet to cool down to proper temperature before reloading product.

#### **SERIAL PLATE LOCATION –**

One serial plate is located on the interior left wall of the cabinet, and a second one in the condensing unit compartment. Both contain all pertinent information such as model, serial number, amperage rating, refrigerant type and charge, etc. Specific charges are DCSG/DCCG-4 16 oz., DCSG/DCCG-8 29 oz., DCSG/DCCG-12 33 oz., and DCSG/DCCG-16 has 31 oz., all have R-404a. The "D" models have the same charge.

#### **TEMPERATURE CONTROL REPLACEMENT –**

The Ranco temperature control is located in the compressor compartment. To replace, first disconnect power supply and remove two screws holding control dial plate. Pull capillary tube from control well, noting length of tube removed. Push new cap tube into well, being careful not to kink it, and making certain it reaches full depth of well.



Replace spade connectors and reinstall dial plate and two screws which hold control in place.

**Operational Data**

The following operational data is based on lab tests, and may vary under field conditions. The conditions shown at the non-recommended high 85°F ambient are shown for information only and a possible reason for jobsite problems. Note that during August, 2002, the DCC/SG-8 cases changed from semi-hermetic (SH) to hermetic (H) and similarly, during December, 2003, the DCC/SG-12 cases changed from the semi-hermetic (SH) to hermetic (H) style compressors which operate under different pressures.

Model	Compressor	Compressor Type	75°F		85°F	
			Suction Pressure	Head Pressure	Suction Pressure	Head Pressure
DCC/SG-4	NE2134GK	H	9	230-240	10	260-270
DCC/SG-8 &-D	HATB-005E-CAA	SH	6	230-240	7	245-255
DCC/SG-8 &-D	T2155GK	H	9	230-240	10	235-245
DCC/SG-12 &-D	KAGB-005E-IAA	SH	6	235-245	7	250-260
DCC/SG-12 &-D	J2212GK	H	10	230-240	11.5	260-270
DCC/SG-16 &-D	KAAB-007E-CAA	SH	6	270-280	7	280-290
Load Line Temperature			0 to +10°F		5 to +12°F	

**TROUBLE SHOOTING CHART**

TRouble	PROBABLE CAUSE	SOLUTION
<b>Compressor will not start, no noise</b>	<b>1. Power disconnected</b>	<b>1. Check service cord for proper connection</b>
	<b>2. Blown fuse or breaker</b>	<b>2. Replace fuse or reset breaker</b>
	<b>3. Defective or broken wiring</b>	<b>3. Repair or replace</b>
	<b>4. Defective overload</b>	<b>4. Replace</b>
	<b>5. Defective temperature</b>	<b>5. Replace control</b>
<b>Compressor will not start cuts out on overload</b>	<b>1. Low voltage</b>	<b>1. Check voltage at cabinet. Should be within 5% of rating</b>
	<b>2. Defective compressor</b>	<b>2. Replace</b>
	<b>3. Defective relay</b>	<b>3. Replace</b>

	<b>4. Restriction pinched cap tube</b>	<b>4. Repair or replace tube</b>
	<b>5. Restriction moisture</b>	<b>5. Leak check, replace drier, evacuate and recharge</b>
	<b>6. Inadequate air over condenser</b>	<b>6. Allow at least 24” at front and back of unit compartment</b>
	<b>7. Defective condenser fan motor</b>	<b>7. Replace</b>

<b>TROUBLE</b>	<b>PROBABLE CAUSE</b>	<b>SOLUTION</b>
<b>High head pressure</b>	<b>1. Cabinet location too warm</b>	<b>1. Relocated cabinet</b>
	<b>2. Restricted condenser air flow</b>	<b>2. Clean condenser or remove air flow restriction</b>
	<b>3. Defective condenser fan motor</b>	<b>3. Replace motor</b>
	<b>4. Air or non-condensable gases in system</b>	<b>4. Leak check, change drier, evacuate and recharge</b>
<b>Warm storage temperatures</b>	<b>1. Temperature control not set properly</b>	<b>1. Reset control</b>
	<b>2. Short of refrigerant</b>	<b>2. Leak check, change drier, evacuate and recharge</b>
	<b>3. Cabinet location too warm</b>	<b>3. Relocate cabinet</b>
	<b>4. Too much refrigerant</b>	<b>4. Purge system, change drier, evacuate and recharge</b>
	<b>5. Low voltage, compressor cycling on overload</b>	<b>5. Check voltage at cabinet. Should be within 5% of rating</b>
	<b>6. Heavy frost on side walls</b>	<b>6. Defrost cabinet</b>
<b>Compressor runs continuously, product too cold</b>	<b>1. Defective control</b>	<b>1. Replace</b>
	<b>2. Control sensing element not completely installed in well</b>	<b>2. Push control sensing element into well</b>
	<b>3. Short on refrigerant</b>	<b>3. Leak check, change drier, evacuate and recharge</b>
<b>Compressor runs continuously, product too warm</b>	<b>1. Short on refrigerant</b>	<b>1. Leak check, change drier, evacuate and recharge</b>
	<b>2. Inefficient compressor</b>	<b>2. Replace</b>

## **DIPPING USERS GUIDE**

The general success of any ice cream dipping department depends to a great extent on the people within that department. If at all possible, a single individual should be assigned the direct responsibility of assuring that proper operational procedures are being followed.

### **LOADING** –

- Careful thought should be given to the placement of flavors within the cabinet prior to the opening of the dipping department. Flavors with the highest sugar content (ripple, maple syrup, and candy) require a lower temperature for dipping than vanilla. Since temperatures will vary slightly within the cabinet, it is recommended that these flavors be placed in the corners where maximum cooling effect from two walls can be taken advantage of.

### **STORAGE** –

- In order to assure product quality and minimum energy usage, it is important that proper attention is given to the maintenance of product temperatures prior to placement in the display freezer. **Storage temperatures** are generally maintained at –12 degrees F to –18 degrees F. This allows for long-term storage of ice cream without deterioration. **Dipping temperatures** are generally maintained at +5 degrees F to +9 degrees F, which allows for rather limited display time before deterioration begins to occur.
- Ice cream removed from a delivery truck, walk-in freezer, or storage cabinet should be placed in the dipping cabinet immediately.
- The dipping cabinet is not designed as a hardening cabinet, and will generally only maintain ice cream at the preset dipping temperature.
- If ice cream is allowed to warm up prior to placement in the dipping cabinet, crystallization may occur resulting in some loss of product quality.

### **LIDS** –

- To conserve energy and minimize frost accumulation on the cabinet interior walls, the lids should remain closed until the customer has made his/her choice of flavors, and should be closed immediately once the customer has been served. Under no circumstances should the cabinet lids be left open for extended periods of time.

## **TEMPERATURE CONTROL** –

- The temperature control is factory set for normal dipping temperatures. If, after a week or so of operation, it is decided that a higher or lower temperature is required, only a qualified refrigeration mechanic should adjust the control. Other than the initial adjustment and possibly a seasonal adjustment, no other setting should be required. If the cabinet temperature fluctuates to any great extent, a refrigeration mechanic should be notified. Employees should not be allowed to tamper within the control setting.

## **LOAD LIMITS** –

- A fully loaded cabinet will use less energy and maintain generally more even temperatures than one that is only partially full. However, care should be taken not to exceed the load line limits as noted on the interior cabinet walls through the use of wire racks, stepshelving, or by stacking containers three high.

## **DIPPING** –

- Much of the success of hand dipping and appeal of the stored ice cream to the customer depends on the training of personnel in proper dipping methods. Periodic scraping of the container sidewalls and leveling off of the ice cream is essential to avoid discoloration and drying out of the ice cream. Scraping the container sidewalls and leveling off the ice cream should be done lightly with the use of a spade. Start with the back of the spade turned towards the side of the can, working from the top of the can down. Once the walls are cleared, the top portion of the remaining ice cream should be leveled off, filling in holes left by previous dipping.

## **MAINTENANCE** –

- Proper maintenance of refrigeration equipment can have a dramatic effect on the equipment's ability to perform, as well as power consumption and customer reaction to your dipping operation.
- Hussmann equipment is designed so that a minimum amount of maintenance is necessary. The relatively few items that do require attention should be scheduled for specific time periods based on prevailing store conditions and cabinet usage.

## **WARRANTY –**

Please read carefully to assure prompt and accurate service

### **Ordering Replacement Parts –**

- Contact your nearest Hussmann
- Always specify model and serial number of
- If correct part number is not known, give a clear description of part itself and its function in the cabinet.

### **Warranty Parts Procedure –**

- Same as items above
- Give original installation date of cabinet and, if possible, forward a copy of the original invoice or delivery receipt.
- All shipments of in-warranty replacement parts will be invoiced from the factory until such time as the defective part is returned and proved to be defective by our Quality Control Department.

Contact your Hussmann Distributor for instructions on returning in-warranty parts.

Warranty parts must be returned to the factory within 30 days of date of failure to assure proper disposition.

Lack of any of the above information may result in the shipment of the wrong part, or a delay in shipment.

### **Compressor Replacement Procedure –**

Replacement compressors will not be shipped from the Hussmann factory. They may be obtained from your nearest Copeland Wholesaler.

Your wholesaler will replace, free of charge, any compressor found to be defective within twelve months of installation, not to exceed twenty months from the date of manufacture, as determined by the compressor serial number on the compressor serial plate. For any defective compressor beyond the twelve or twenty month time period, a salvage value credit will be given too partially offset the invoice for the replacement.

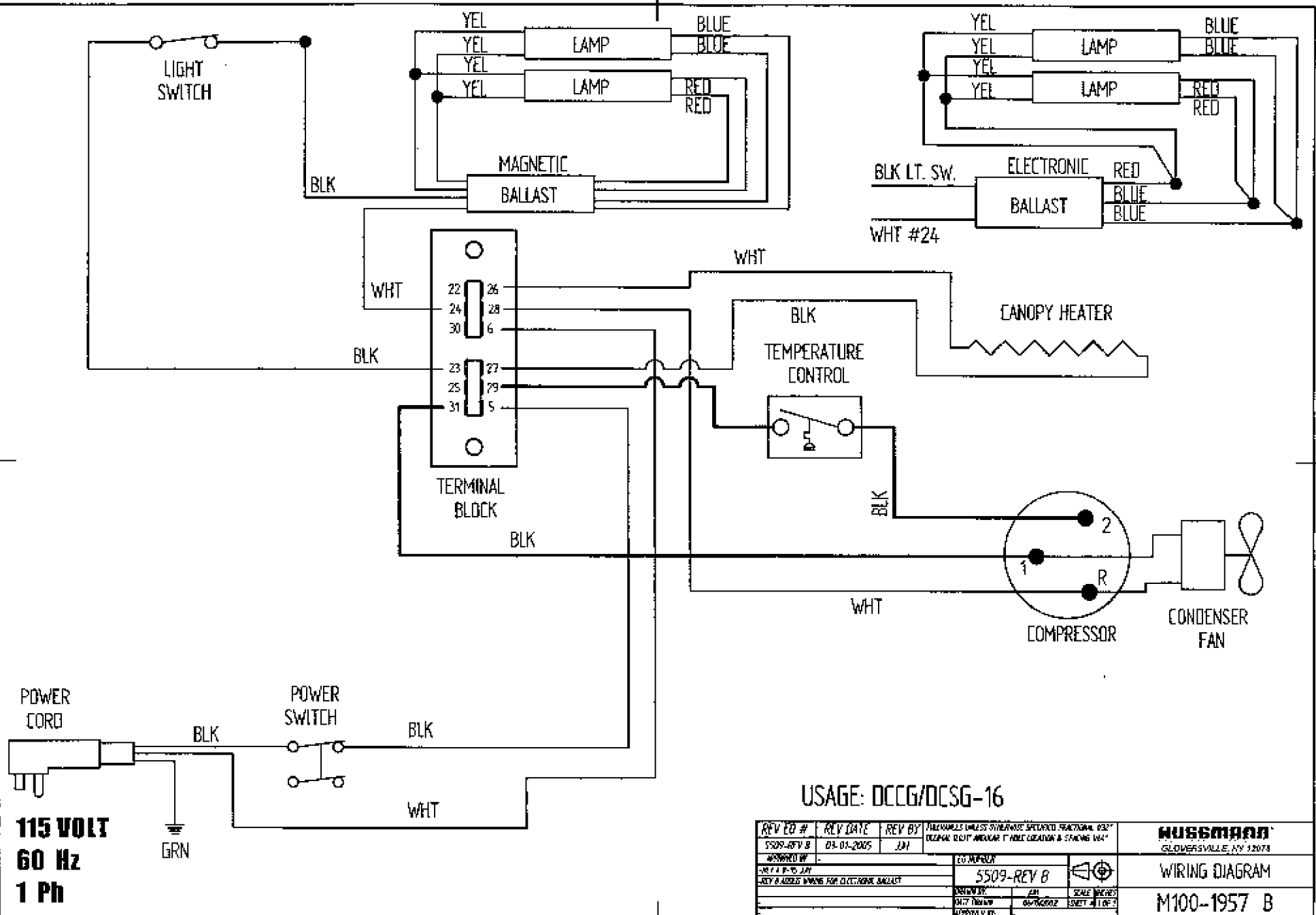

**115 VOLT**  
**60 Hz**  
**1 Ph**

USAGE: DCCG/DCSG-16

REV ED #	REV DATE	REV BY	REVISIONS UNLESS OTHERWISE SPECIFIED FRACTIONAL REV*	 <b>HUSMANN</b> GLOVERSVILLE, NY 12078
5509-REV B	09-01-2005	JAH	ORIGINAL BUILT UNDER A "B" MODEL DESIGNATION & STATIONING USA*	
APPROVED BY			ED APPROVAL	 SCALE INCHES 1/8" = 1'-0"
DATE: 8-14-10-JAH			5509-REV B	
REV B ADDED WIRING FOR ELECTRONIC BALLAST			DRAWN BY: JAH	SHEET # 1 OF 2 <b>M100-1957 B</b>
			CHECKED BY: GW/AGG/02	
			APPROVAL BY:	

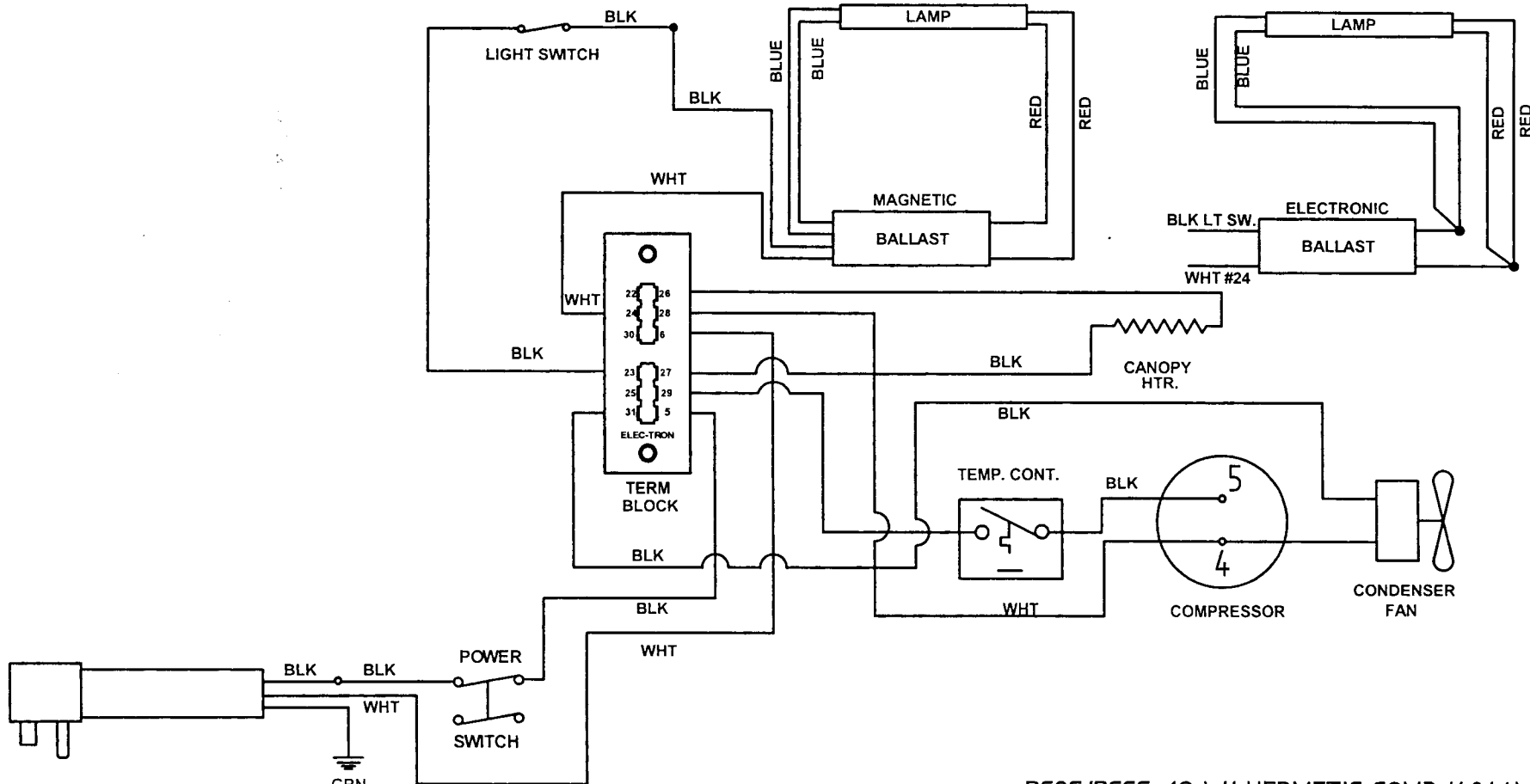

115 VOLT  
60 Hz  
1 Ph

SHEET 1 OF 2

DCSG/DCCG-12 W/ HERMETIC COMP (404A)

				MATERIAL:	SHEET SIZE	TOLERANCES UNLESS OTHERWISE SPECIFIED.
				XXXXXX-XX	<b>B</b>	FRACTIONAL <input type="checkbox"/> 1/32"
						DECIMAL <input type="checkbox"/> 0.031"
				SIZE	XXXXXXX	ANGULAR <input type="checkbox"/> 1/8"
B	03-01-05	JJH	5509			HOLE LOCATION & SPACING <input type="checkbox"/> 0.184"
A	08/02/95	JJH				SCALE: NONE
REV.	DATE	BY	E.C.N.	DIE NO.	XXXX-XXXX	FINISH XXXXXXXXXXXXX

<b>HUSSMANN</b> <small>Gloversville, N.Y. 12078</small>			
<b>TITLE</b> WIRING DIAGRAM DCSG/DCCG-12			
TYPE	DRAWN	DWG. NUMBER	REV.
CODE	JJH	M100-2306	B
DATE	0803		
CHECKED	XXX		

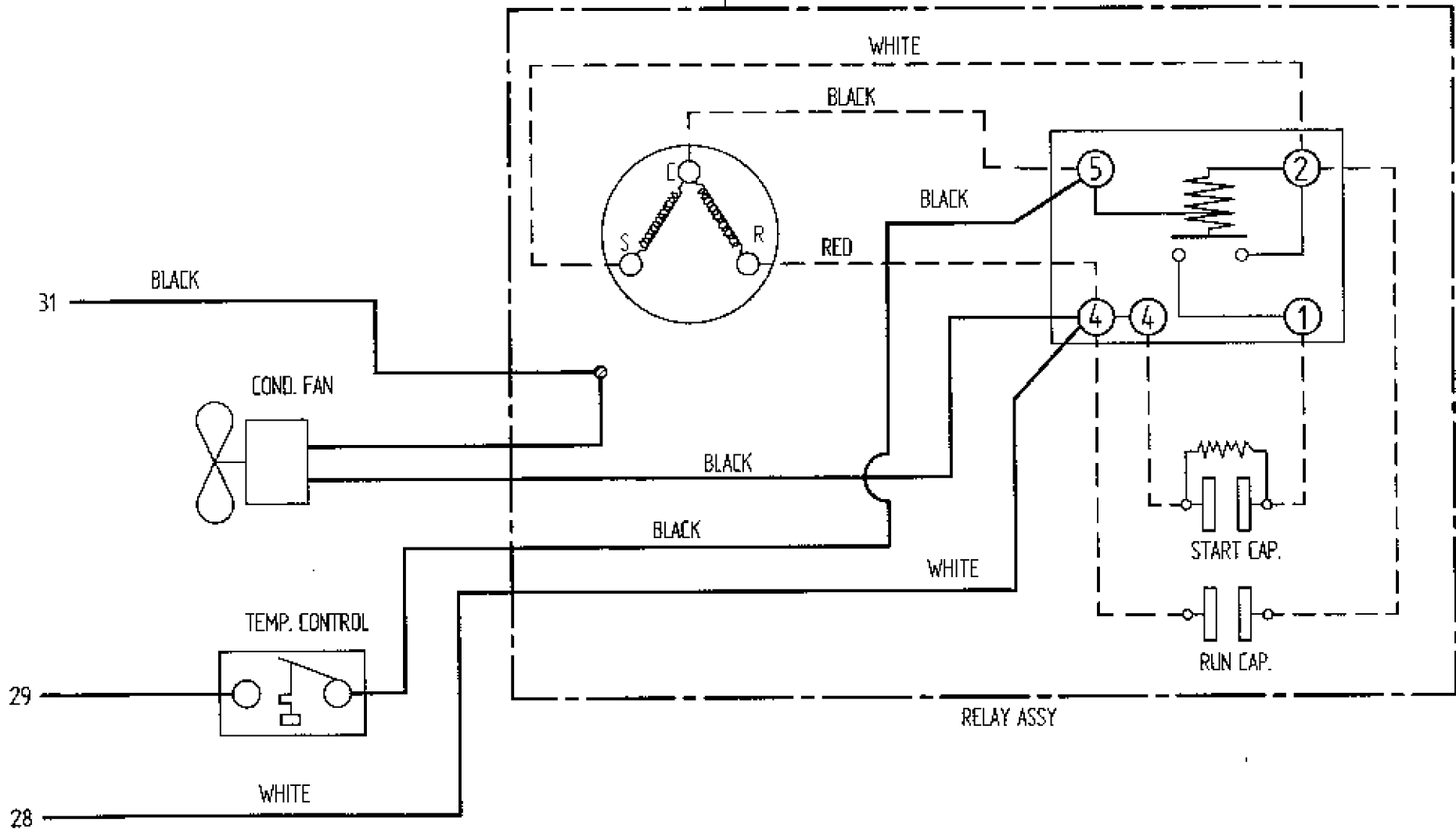

SHEET 2 OF 2

REVISED #	REV DATE	REV BY	TECHNICALS CHECKS OTHERWISE SPECIFIED FRACTIONAL USE*	<b>HUBBARD</b> 61 PARKVILLE E, NY 12978
5509-REV B	03-01-2005	JM	INCLUDE GOST AND IEC 7102 LOCATION & SPACING USE*	
APPROVED BY			LD NUMBER	
REV A & B-35 JEM			5509-REV B	
REV A WIRE WOUNDS FOR ELECTRONIC BALLAST			DRAWN BY	25
			DATE DRAWN	RECORDED
			DESIGNED BY	SHEET 4 OF 1

WIRING DIAGRAM  
M100-2306 B



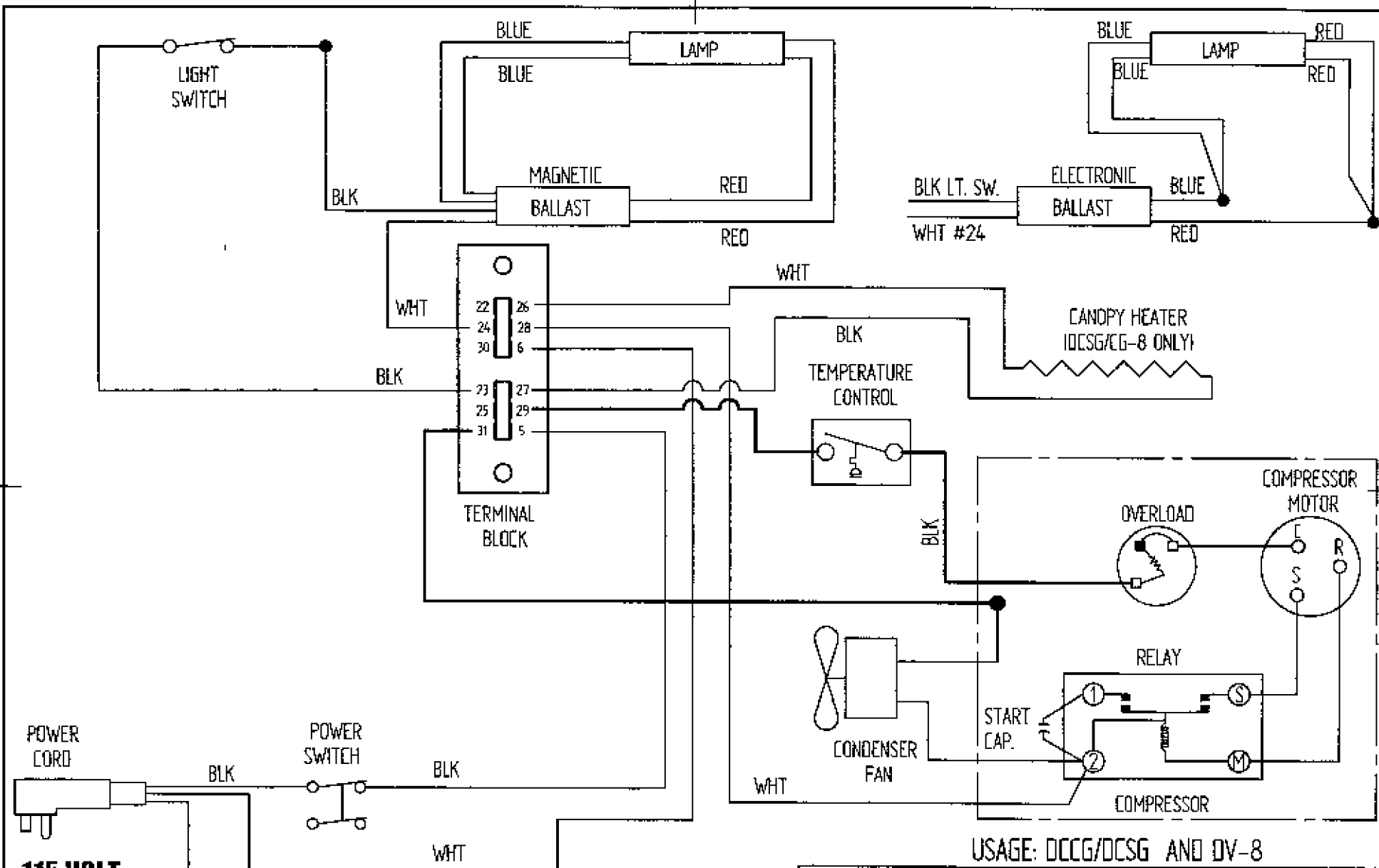

**115 VOLT**  
**60 Hz**  
**1 Ph**

GRN

USAGE: DCCG/DCSG AND DV-8

REV ED #	REV DATE	REV BY	TOLERANCES UNLESS OTHERWISE SPECIFIED FRACTIONAL 1/32" DECIMAL 0.031" MINIMUM 1" MIN LOCATIONS & SPACING 1/16"	 HUSMANN OR OVERVILLE, NY 12078
5509-REV A	03-04-2005	JUN	ED NUMBER: 5509-REV A	
APPROVED BY:			DATE DRAWN:	SCALE: 1/16" = 1"
-USE A QUALITY WIRE FOR ELECTRONIC BALLAST			DATE CHECKED:	APPROVED BY:
			DATE APPROVED:	

WIRING DIAGRAM  
M100-2281 A

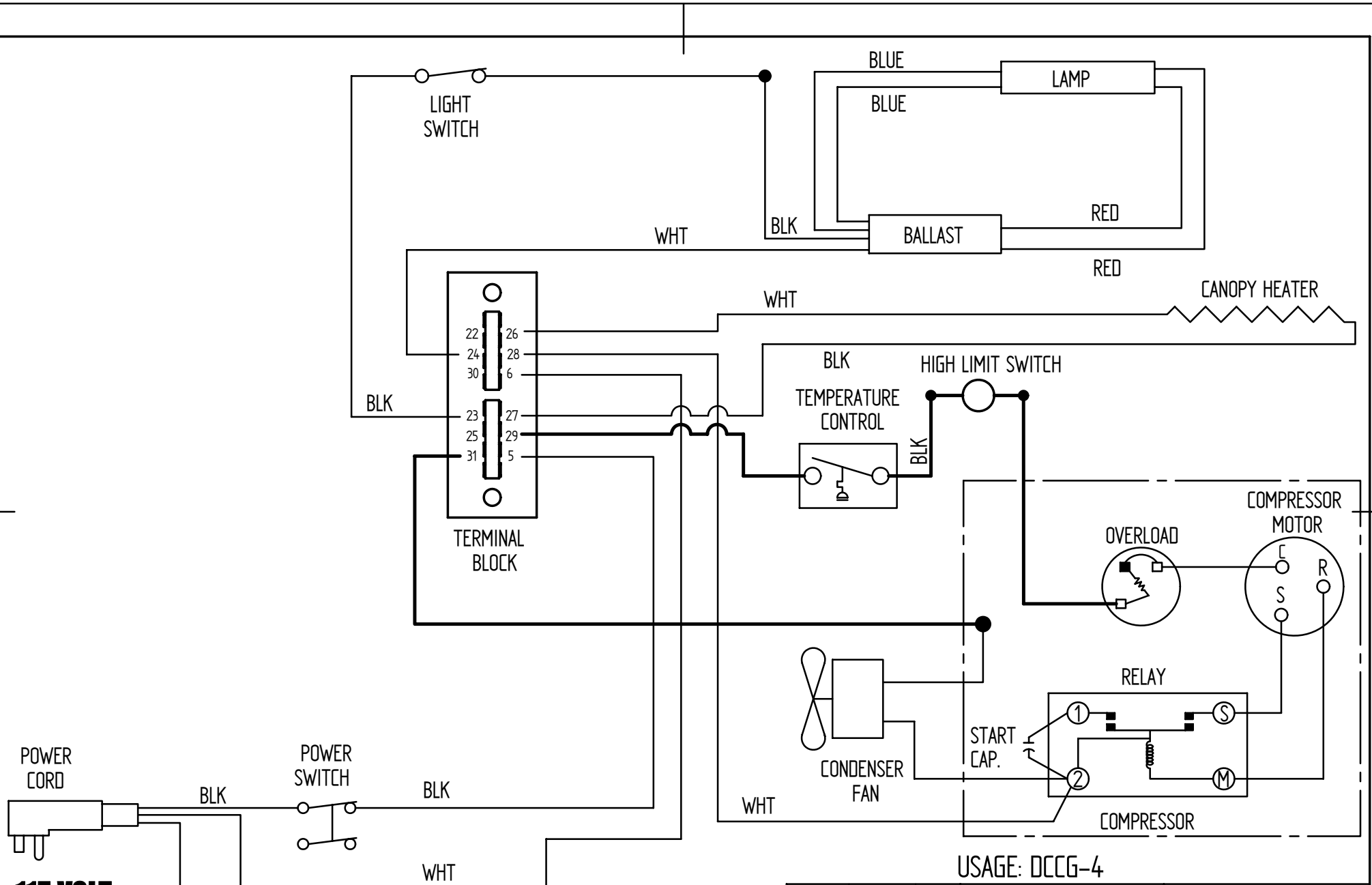

**115 VOLT**  
**60 Hz**  
**1 Ph**

GRN

USAGE: DCCG-4

REV E.O. #	REV DATE	REV BY	TOLERANCES UNLESS OTHERWISE SPECIFIED FRACTIONAL 1/32" DECIMAL 0.031" ANGULAR 1° HOLE LOCATION & SPACING 1/64"	HUSMANN® GLOVERSVILLE, NY 12078
-	-	-		
APPROVED BY:			ED NUMBER	
			DRAWN BY: JH	SCALE: INCHES
			DATE DRAWN: 01/29/2004	SHEET # 1 OF 1
			APPROVED BY:	
				WIRING DIAGRAM
				M100-2309