

**MEDIUM SIZE  
INDOOR UNIT  
STANDARD BASE  
"HNSx-xxxxxxx-xx-A"  
WEIGHT: 650 LBS.**

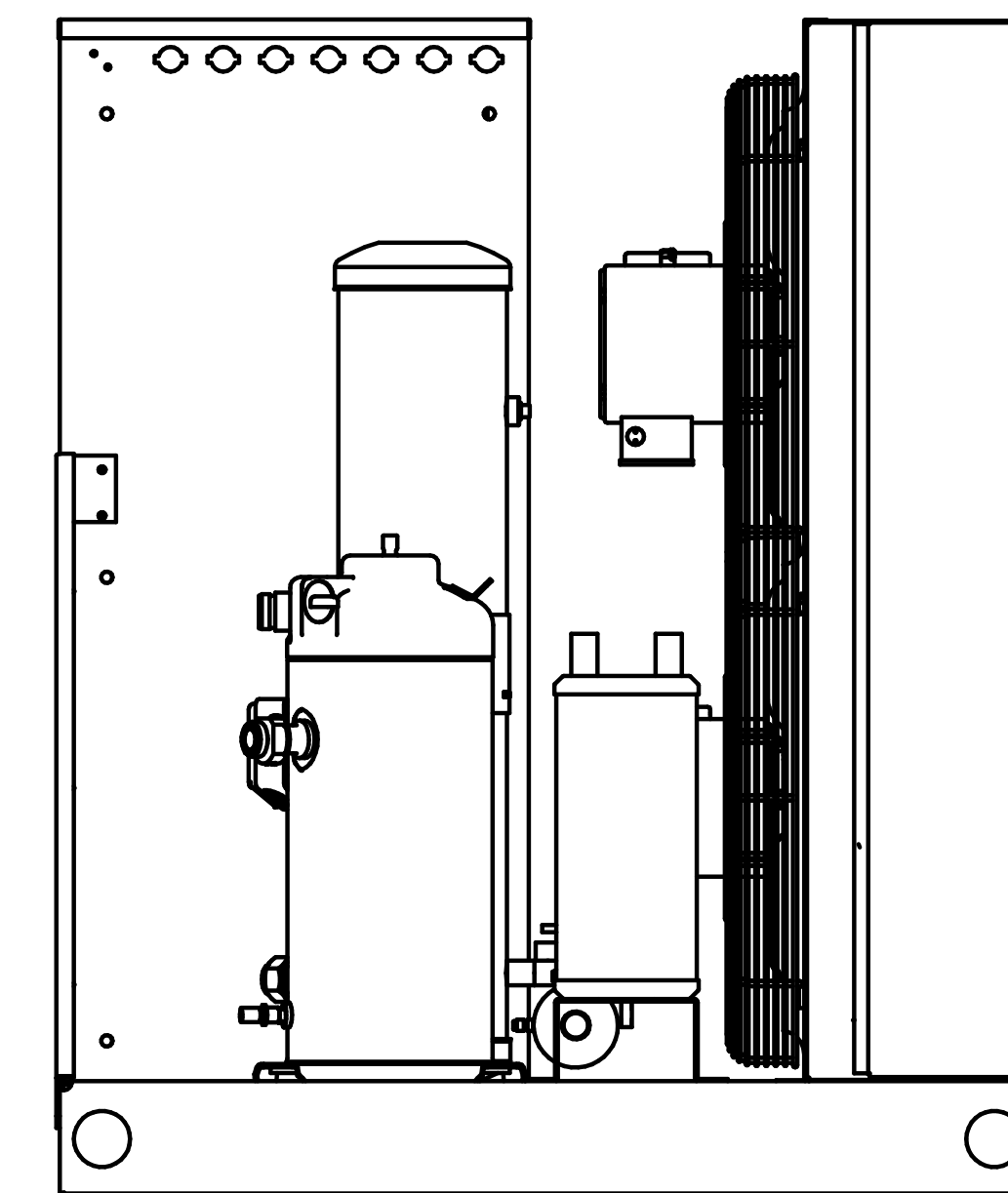
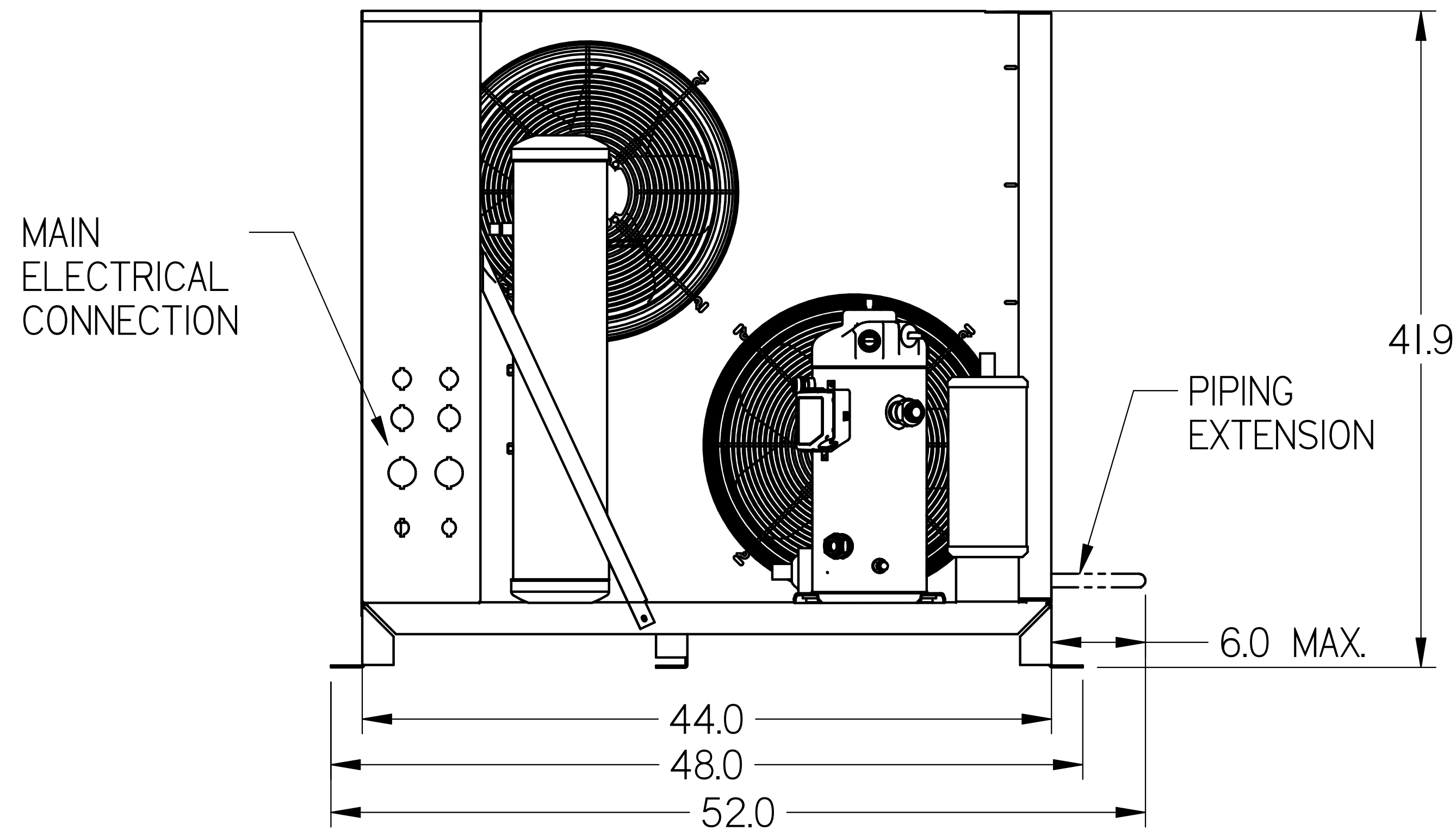
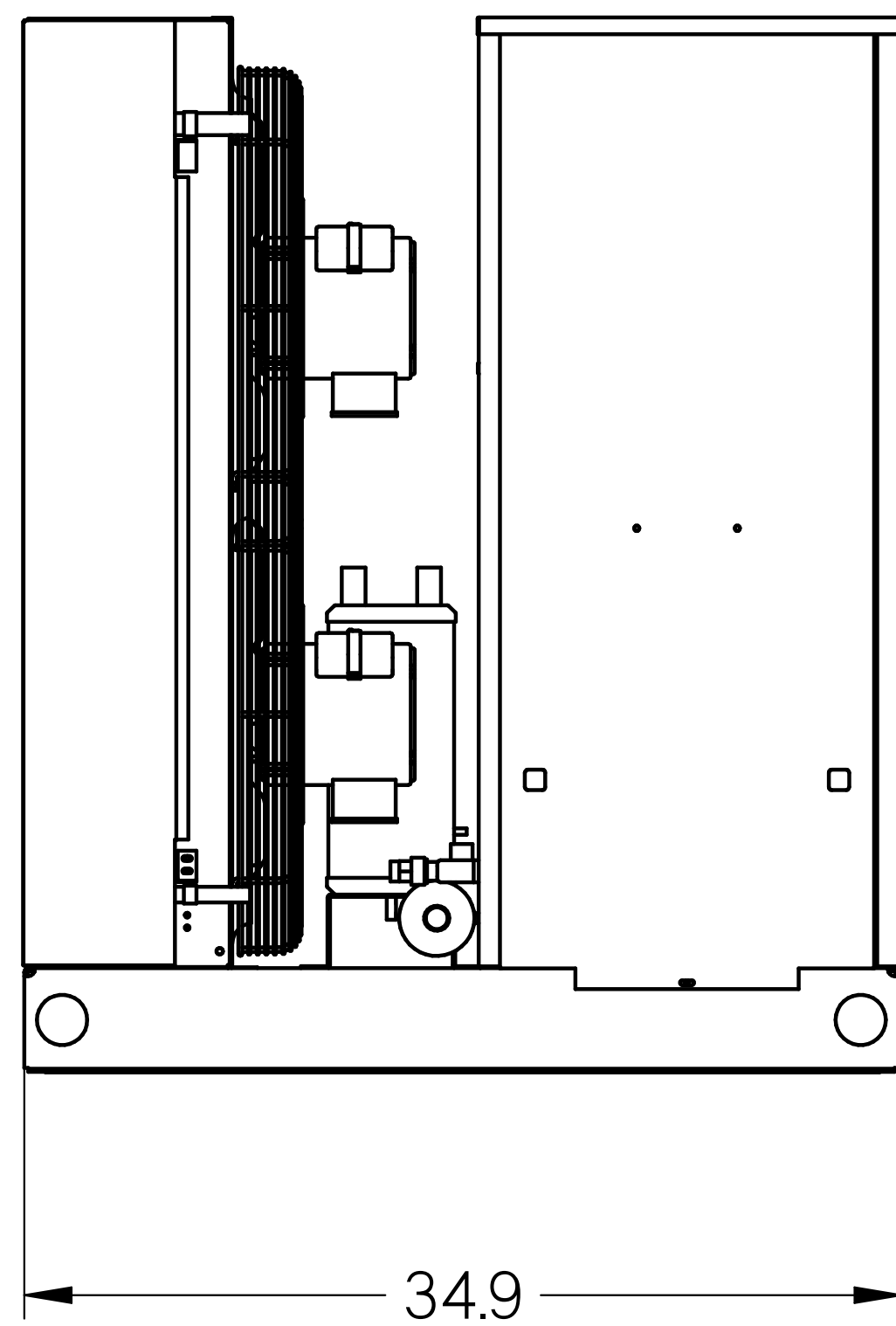
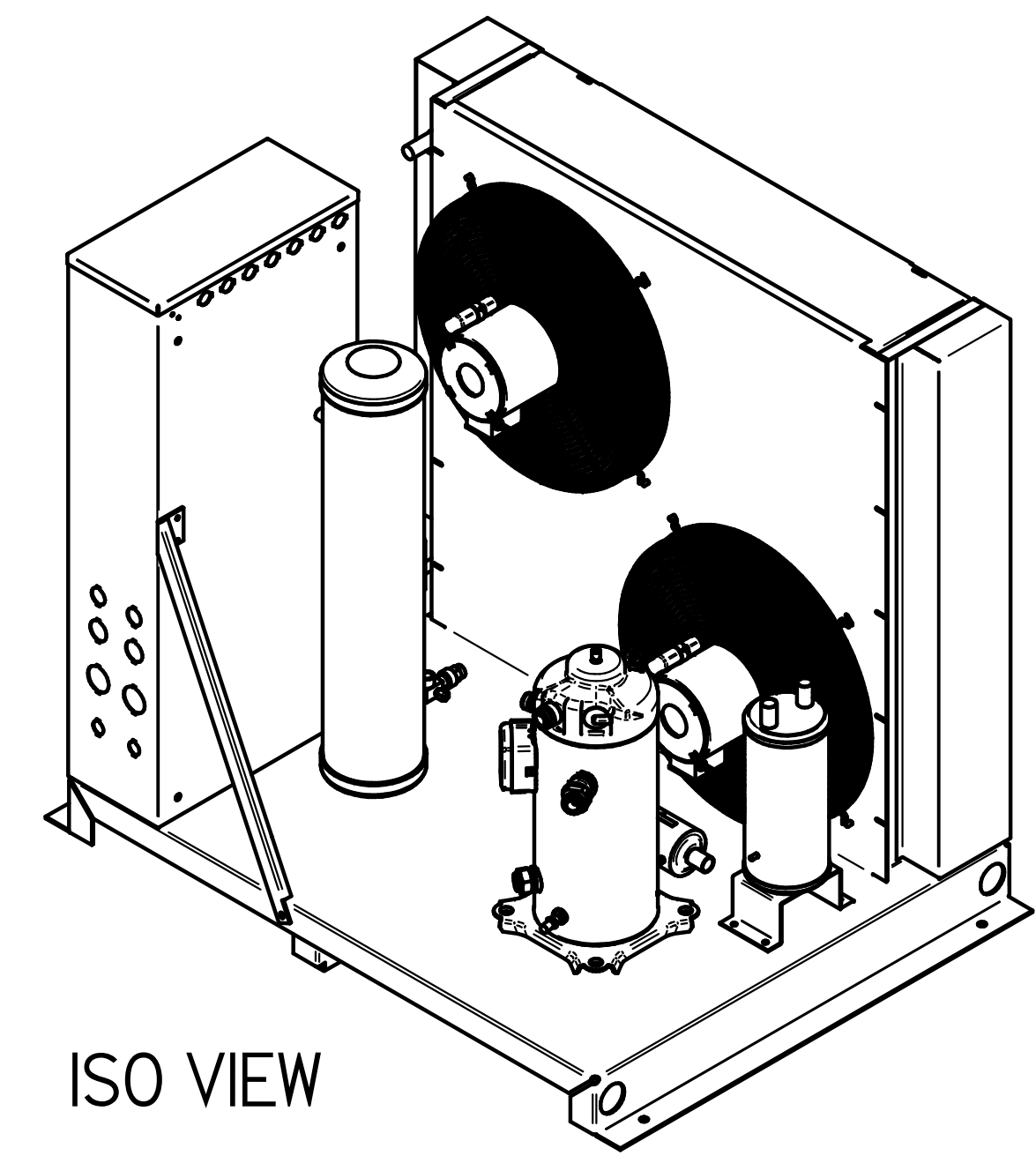
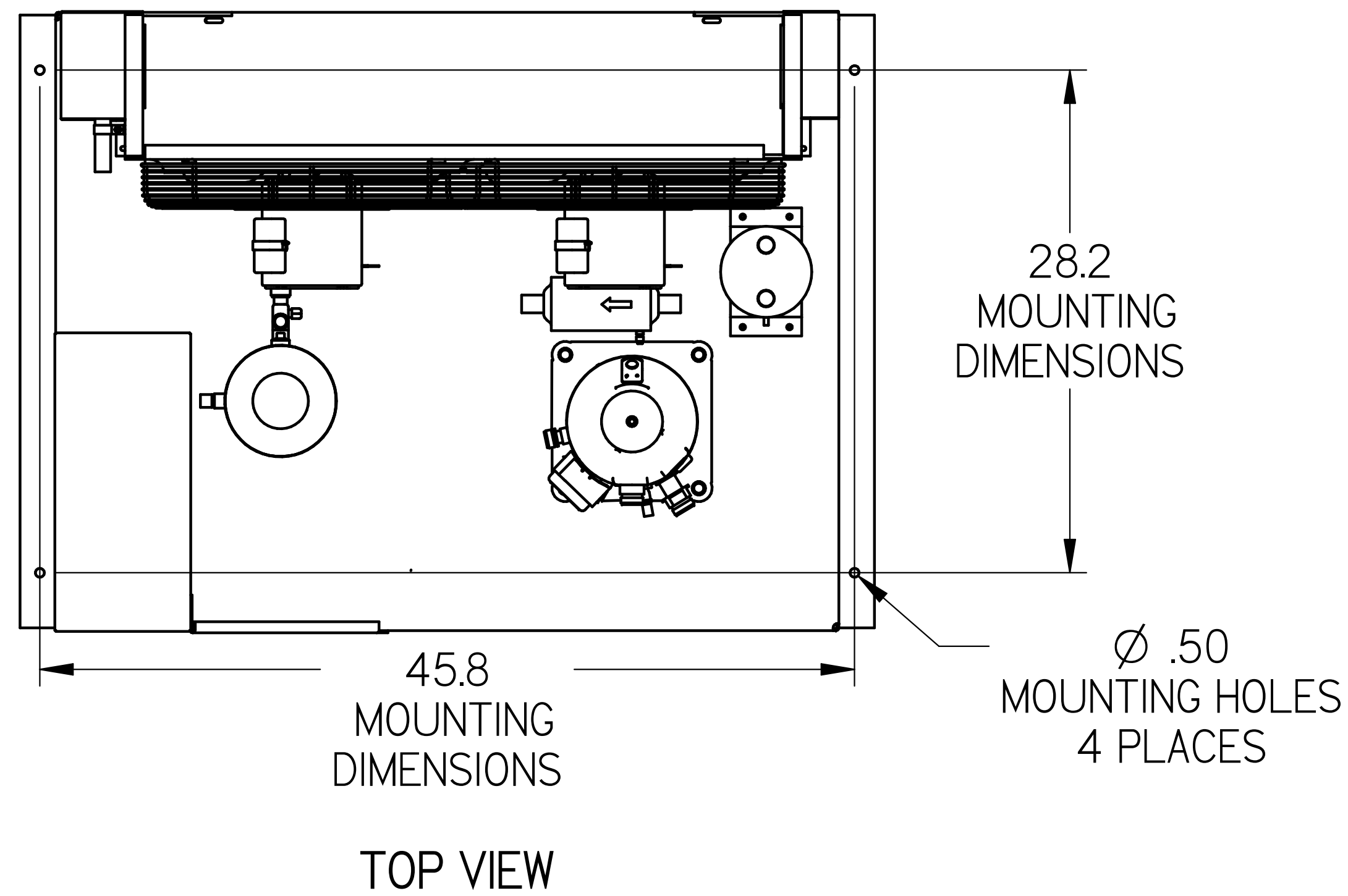

NOTES:

1. IT IS THE RESPONSIBILITY OF THE INSTALLING CONTRACTOR TO ENSURE THAT THE FINAL EQUIPMENT INSTALLATION MEETS ALL APPLICABLE CODE REQUIREMENTS.
2. ILLUSTRATION SHOWN IS FOR GENERAL REPRESENTATION ONLY. ACTUAL PRODUCT WILL VARY DEPENDENT UPON APPLICATION.
3. OVERALL DIMENSIONS: 52 L X 34.9 W X 41.9 H.

INFORMATION SUBJECT TO CHANGE

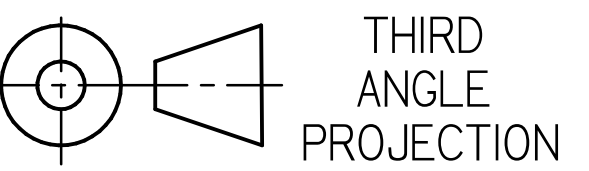
DIMENSIONS ARE IN INCHES. DATE DRAWN: 2017/09/14	<b>HUSSMANN</b> <sup>®</sup>
 THIRD ANGLE PROJECTION	H SERIES MEDIUM INDOOR STD BASE
SHEET 1 OF 3	DOC PD-000000005 REV C

SWN 1.0 SUBMITTAL SHEET SIZE D

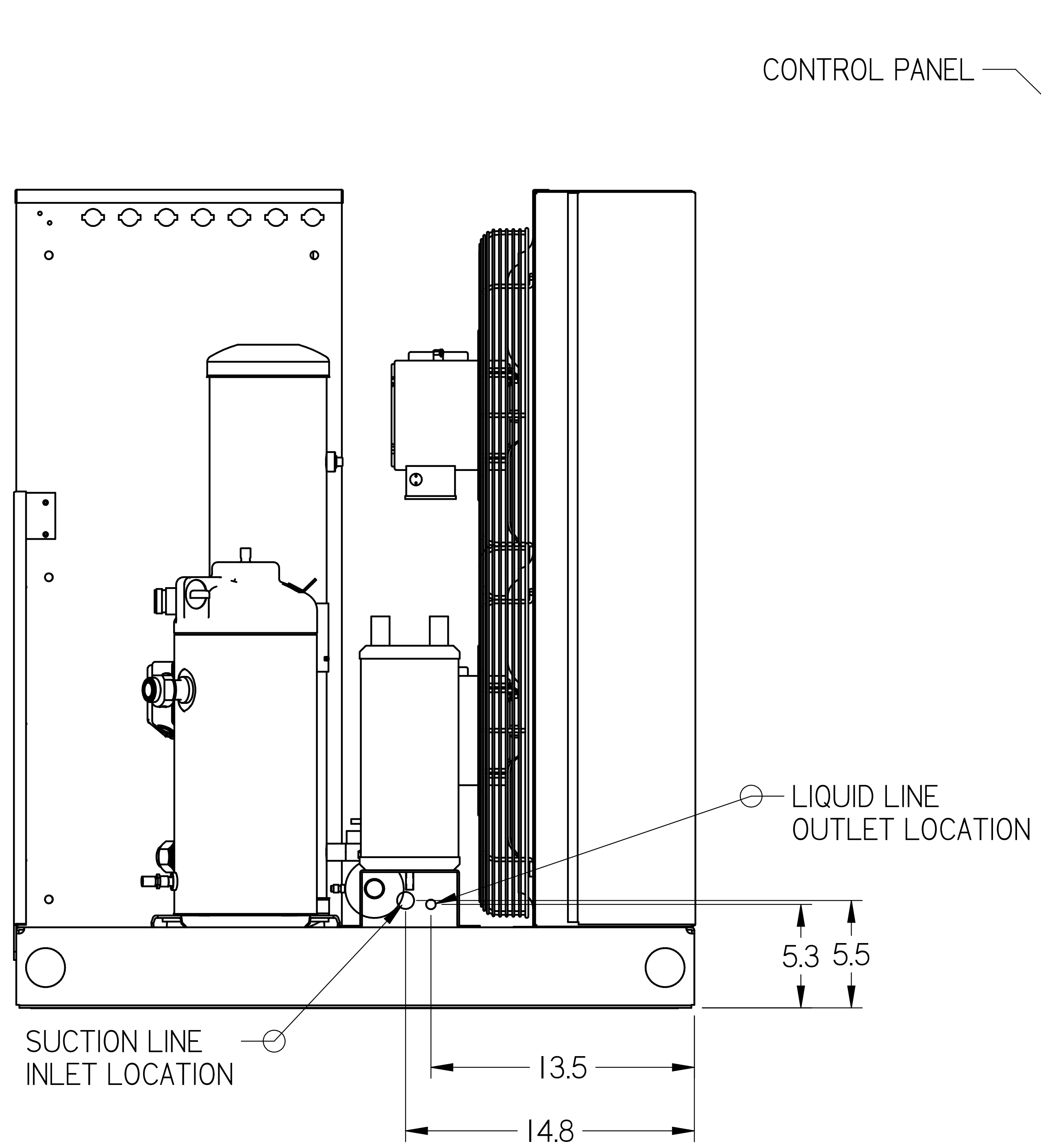

PIPING CONNECTION LOCATION  
OUT RIGHT SIDE OF UNIT

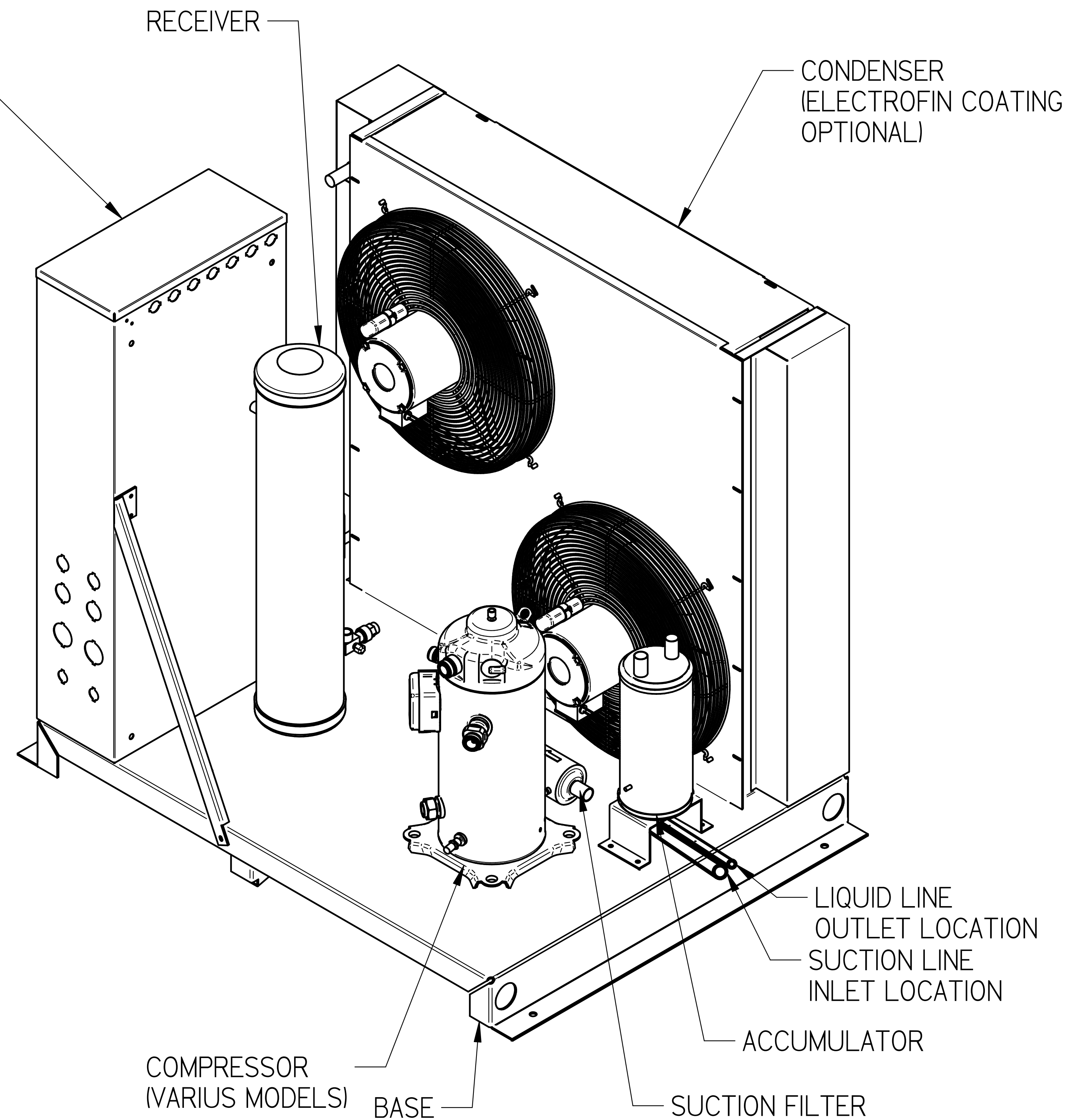

ISO VIEW

NOTES:

1. IT IS THE RESPONSIBILITY OF THE INSTALLING CONTRACTOR TO ENSURE THAT THE FINAL EQUIPMENT INSTALLATION MEETS ALL APPLICABLE CODE REQUIREMENTS.
2. ILLUSTRATION SHOWN IS FOR GENERAL REPRESENTATION ONLY. ACTUAL PRODUCT WILL VARY DEPENDENT UPON APPLICATION.
3. OVERALL DIMENSIONS: 52 L X 34.9 W X 41.9 H.

DIMENSIONS ARE IN INCHES.  
DATE DRAWN: 2017/09/14

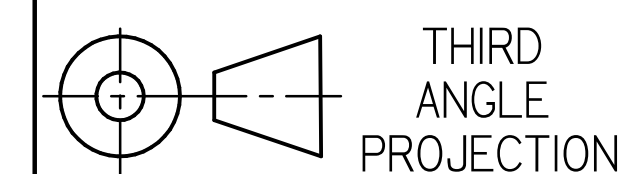

**HUSSMANN**<sup>®</sup>

H SERIES MEDIUM  
INDOOR STD BASE

INFORMATION SUBJECT TO CHANGE

SHEET 2 OF 3

DOC PD-000000005 REV C

SWN 1.0 SUBMITTAL SHEET SIZE D

**MINIMUM CLEARANCE REQUIREMENTS:**

ACTUAL CLEARANCE REQUIREMENTS ARE DEPENDENT UPON AUTHORITY HAVING JURISDICTION, AND MAY EXCEED DIMENSIONS SHOWN.

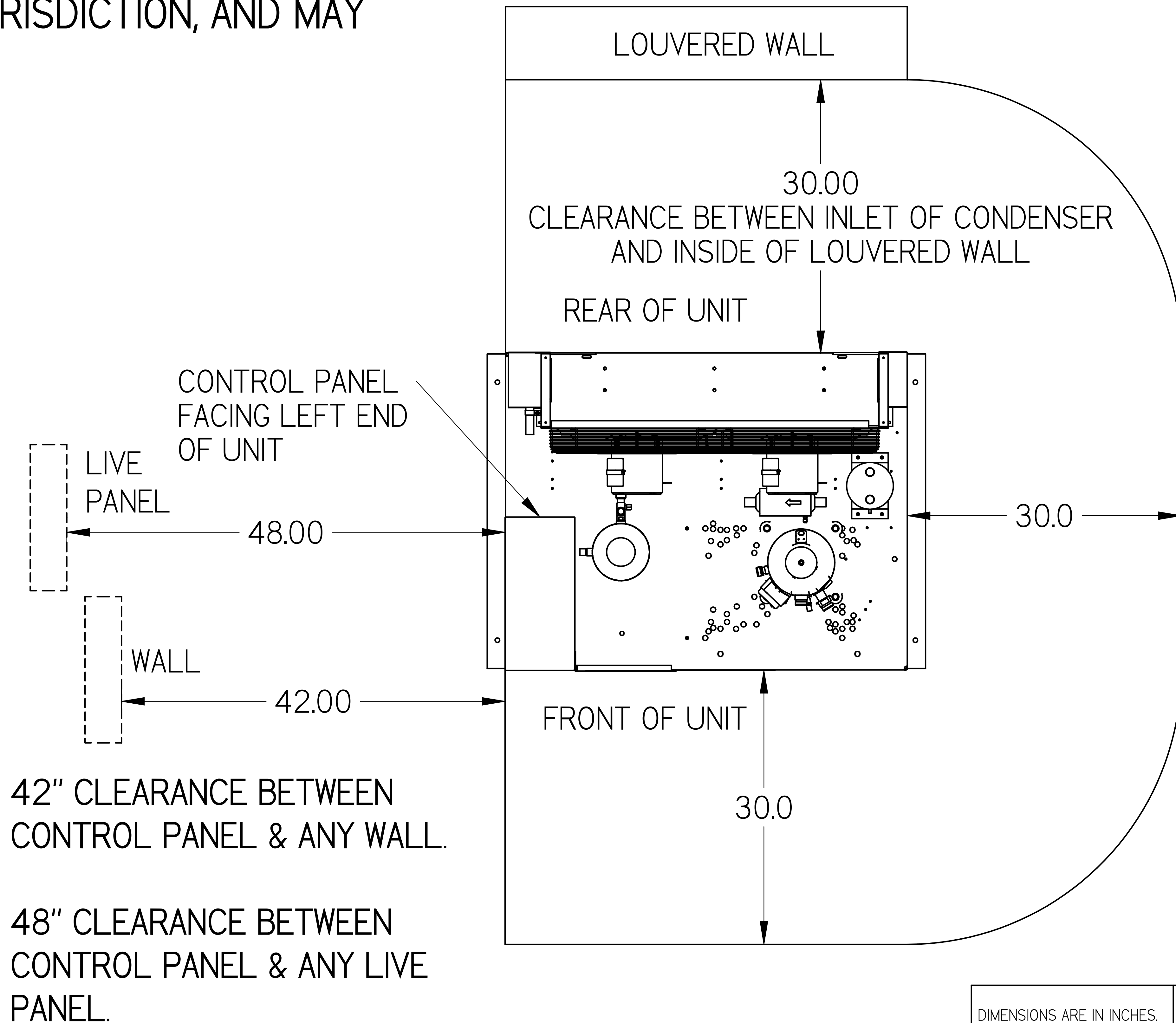

NOTES:

1. IT IS THE RESPONSIBILITY OF THE INSTALLING CONTRACTOR TO ENSURE THAT THE FINAL EQUIPMENT INSTALLATION MEETS ALL APPLICABLE CODE REQUIREMENTS.
2. ILLUSTRATION SHOWN IS FOR GENERAL REPRESENTATION ONLY. ACTUAL PRODUCT WILL VARY DEPENDENT UPON APPLICATION.
3. OVERALL DIMENSIONS: 52 L X 34.9 W X 41.9 H.

INFORMATION SUBJECT TO CHANGE

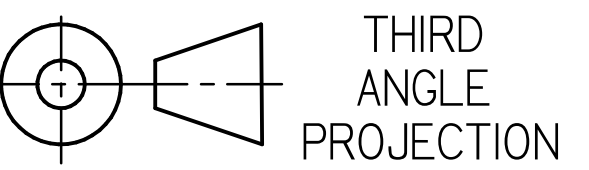
DIMENSIONS ARE IN INCHES. DATE DRAWN: 2017/09/14	<b>HUSSMANN</b> <sup>®</sup>
 THIRD ANGLE PROJECTION	H SERIES MEDIUM INDOOR STD BASE
SHEET 3 OF 3	DOC PD-000000005 REV C

SWN 1.0 SUBMITTAL SHEET SIZE D