

**LARGE SIZE
INDOOR UNIT
HEAVY DUTY BASE
"HNHx-xxxxxxx-xx-A"
WEIGHT: 1,250 LBS.**

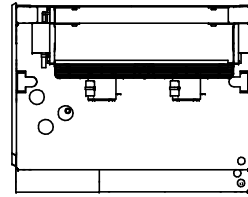

TOP VIEW

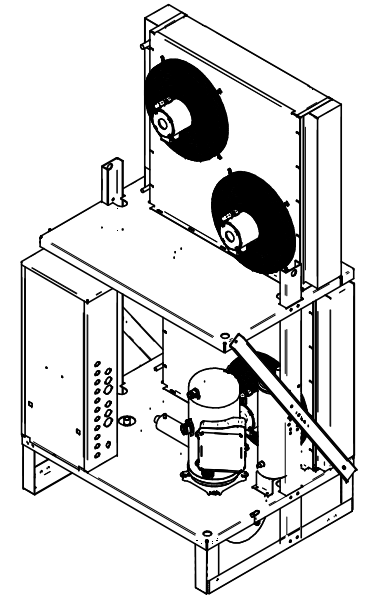

ISO VIEW

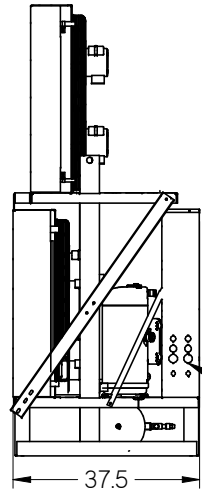

LEFT SIDE VIEW

MAIN ELECTRICAL CONNECTION

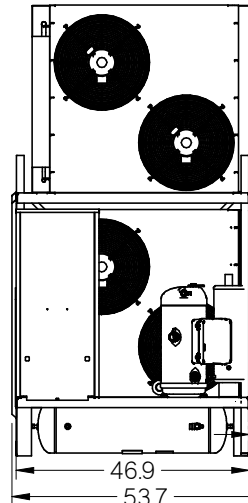

FRONT VIEW

PIPING EXTENSION

6.0 MAX.

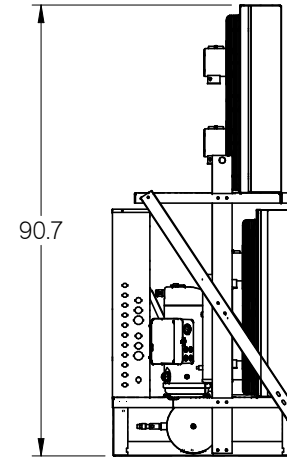

RIGHT SIDE VIEW

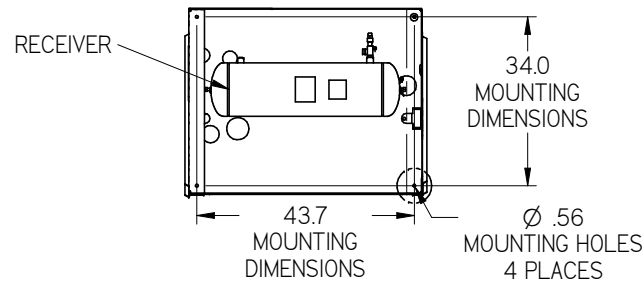

RECEIVER

34.0 MOUNTING DIMENSIONS

43.7 MOUNTING DIMENSIONS

Ø .56 MOUNTING HOLES 4 PLACES

NOTES:

1. IT IS THE RESPONSIBILITY OF THE INSTALLING CONTRACTOR TO ENSURE THAT THE FINAL EQUIPMENT INSTALLATION MEETS ALL APPLICABLE CODE REQUIREMENTS.
2. ILLUSTRATION SHOWN IS FOR GENERAL REPRESENTATION ONLY. ACTUAL PRODUCT WILL VARY DEPENDENT UPON APPLICATION.
3. OVERALL DIMENSIONS: 53.7 L X 37.5 W X 90.7 H.

INFORMATION SUBJECT TO CHANGE

DIMENSIONS ARE IN INCHES.
DATE DRAWN: 2017/09/14



THIRD ANGLE PROJECTION

SHEET 1 OF 3

HUSSmann®

H SERIES LARGE
INDOOR HD BASE

DOC PD-000000011 REV B

SWIN10 SUBMITTAL SHEET SIZE D

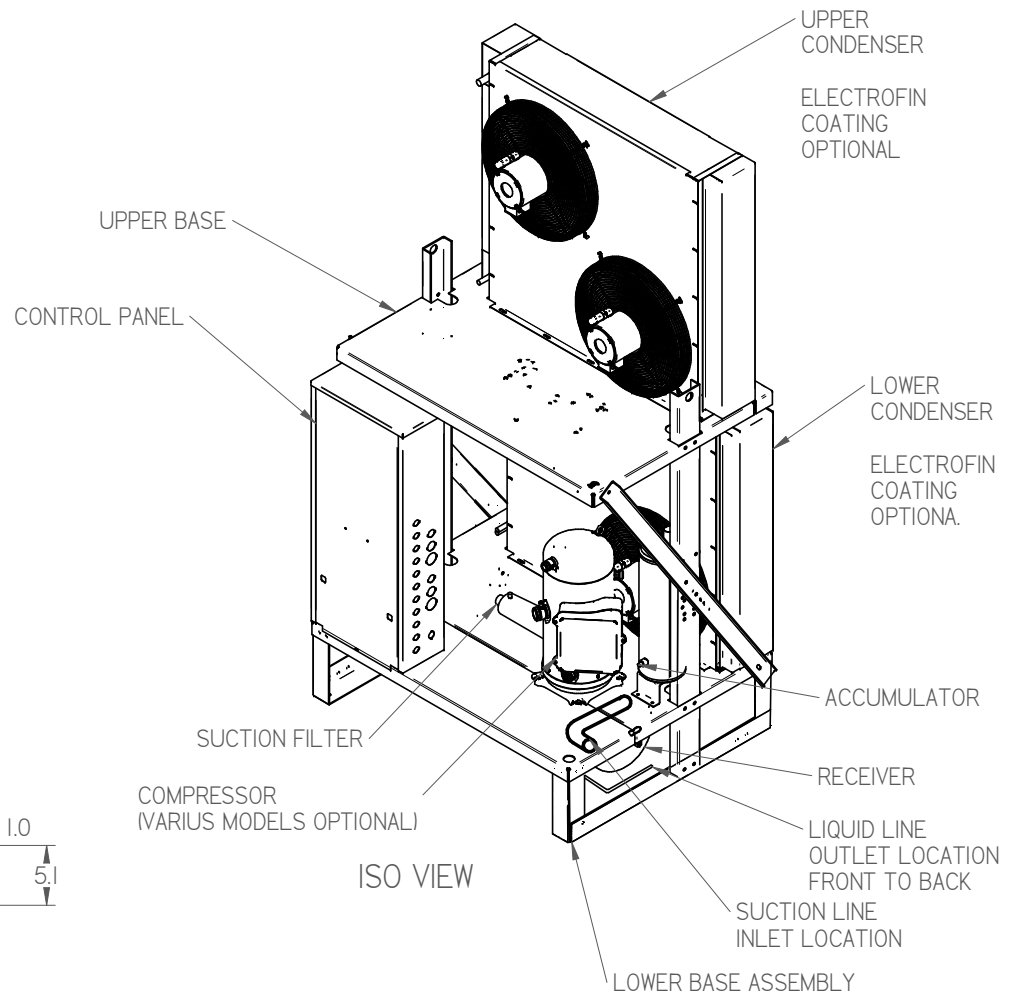
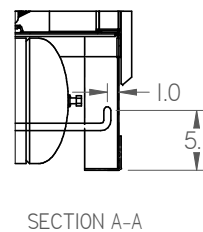
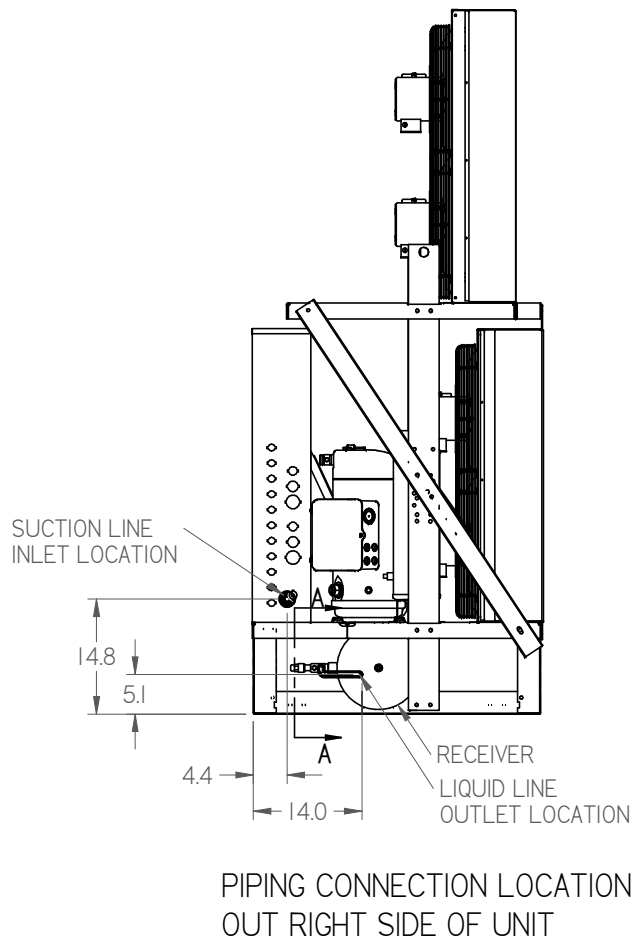

NOTES:

1. IT IS THE RESPONSIBILITY OF THE INSTALLING CONTRACTOR TO ENSURE THAT THE FINAL EQUIPMENT INSTALLATION MEETS ALL APPLICABLE CODE REQUIREMENTS.
2. ILLUSTRATION SHOWN IS FOR GENERAL REPRESENTATION ONLY. ACTUAL PRODUCT WILL VARY DEPENDENT UPON APPLICATION.
3. OVERALL DIMENSIONS: 53.7 L X 37.5 W X 90.7 H.

DIMENSIONS ARE IN INCHES.
DATE DRAWN: 2017/09/14



INFORMATION SUBJECT TO CHANGE

SHEET 2 OF 3

HUSSmann®

H SERIES LARGE
INDOOR HD BASE

DOC PD-000000011 REV B

SHEET SUBMITTAL SHEET SIZE D

MINIMUM CLEARANCE REQUIREMENTS:

ACTUAL CLEARANCE REQUIREMENTS ARE DEPENDENT UPON AUTHORITY HAVING JURISDICTION, AND MAY EXCEED DIMENSIONS SHOWN.

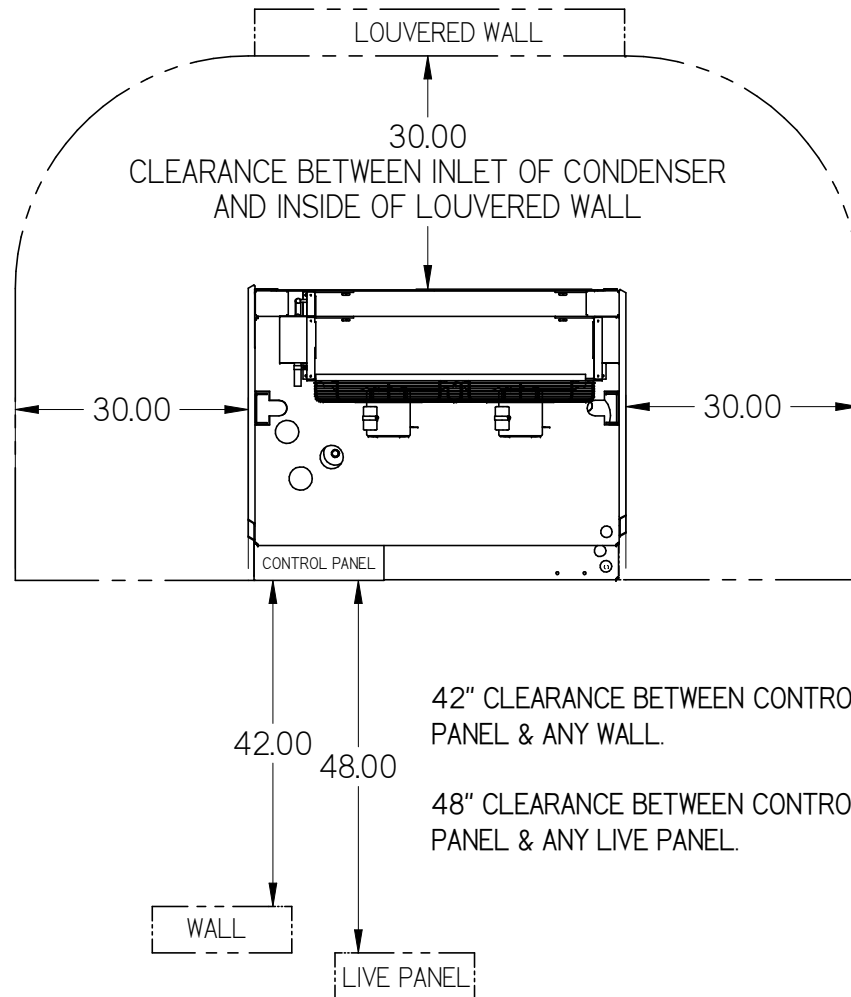

NOTES:

1. IT IS THE RESPONSIBILITY OF THE INSTALLING CONTRACTOR TO ENSURE THAT THE FINAL EQUIPMENT INSTALLATION MEETS ALL APPLICABLE CODE REQUIREMENTS.
2. ILLUSTRATION SHOWN IS FOR GENERAL REPRESENTATION ONLY. ACTUAL PRODUCT WILL VARY DEPENDENT UPON APPLICATION.
3. OVERALL DIMENSIONS: 53.7 L X 37.5 W X 90.7 H.

DIMENSIONS ARE IN INCHES.
DATE DRAWN: 2017/09/14



HUSSmann®

H SERIES LARGE
INDOOR HD BASE

INFORMATION SUBJECT TO CHANGE

SHEET 3 OF 3

DOC PD-000000011 REV B

SHEET SUBMITTAL SHEET SIZE D