

**LARGE SIZE  
OUTDOOR UNIT  
STANDARD BASE  
"HTSx-xxxxxxx-xx-A"  
WEIGHT: 1,250 LBS**

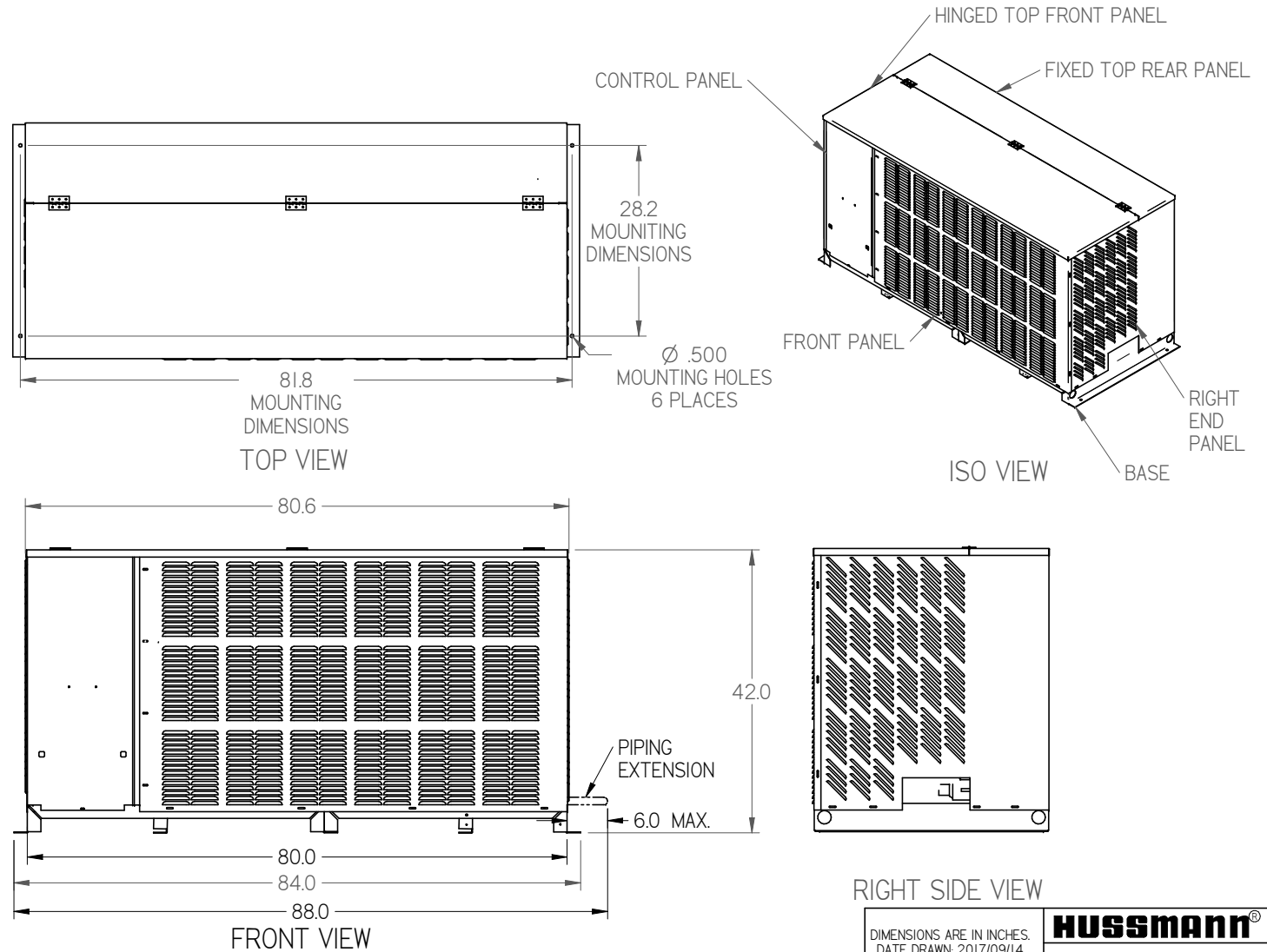

**NOTES:**

1. IT IS THE RESPONSIBILITY OF THE INSTALLING CONTRACTOR TO ENSURE THAT THE FINAL EQUIPMENT INSTALLATION MEETS ALL APPLICABLE CODE REQUIREMENTS.
2. ILLUSTRATION SHOWN IS FOR GENERAL REPRESENTATION ONLY. ACTUAL PRODUCT WILL VARY DEPENDENT UPON APPLICATION.
3. OVERALL DIMENSIONS: 88 L X 35.1 W X 42 H.

DIMENSIONS ARE IN INCHES.  
DATE DRAWN: 2017/09/14



INFORMATION SUBJECT TO CHANGE

SHEET 1 OF 3

**HUSSMANN®**

H SERIES LARGE  
OUTDOOR STD BASE

DOC PD-00000015 REV B

SWIN10 SUBMITTAL SHEET SIZE D

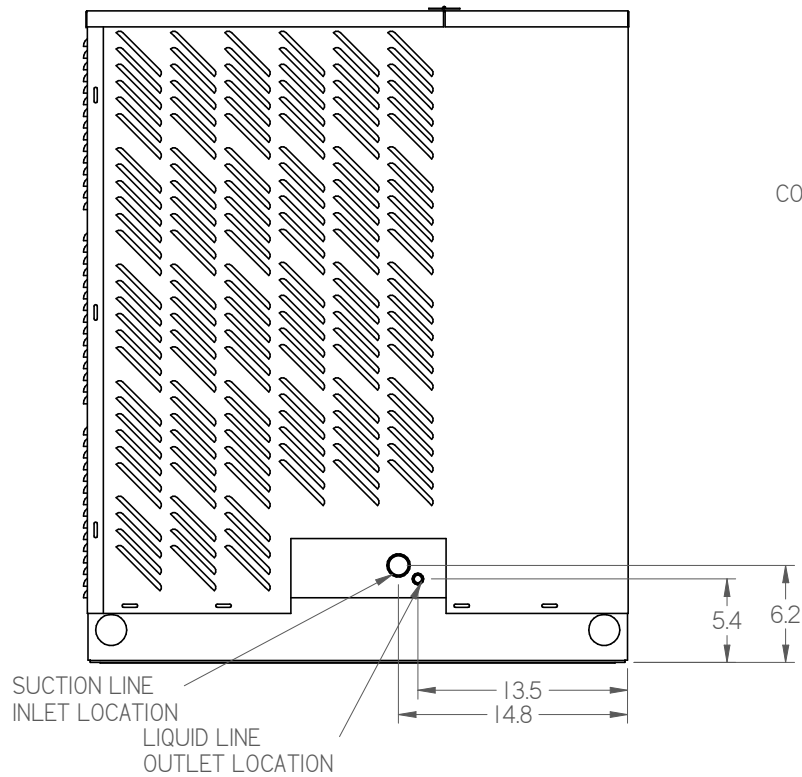

PIPING CONNECTION LOCATION  
OUT RIGHT SIDE OF UNIT

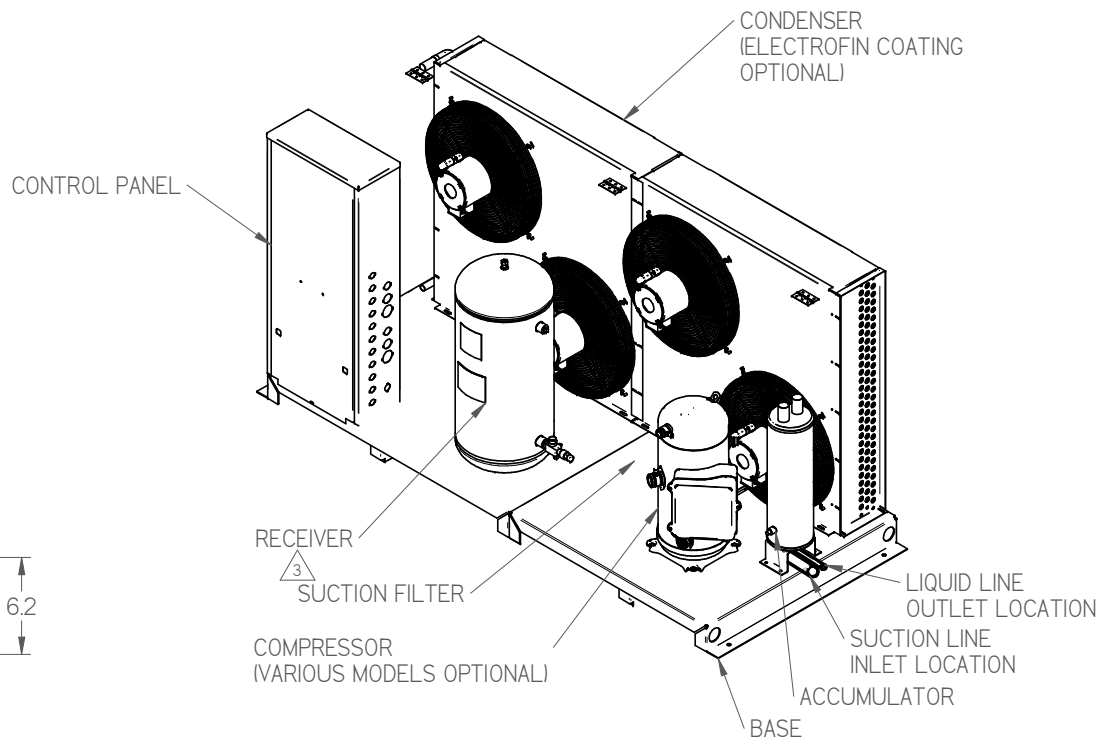

ISO VIEW WITH OUTDOOR HOUSING  
REMOVED FOR CLARITY

NOTES:

1. IT IS THE RESPONSIBILITY OF THE INSTALLING CONTRACTOR TO ENSURE THAT THE FINAL EQUIPMENT INSTALLATION MEETS ALL APPLICABLE CODE REQUIREMENTS.
2. ILLUSTRATION SHOWN IS FOR GENERAL REPRESENTATION ONLY. ACTUAL PRODUCT WILL VARY DEPENDENT UPON APPLICATION.
3. OVERALL DIMENSIONS: 88 L X 35.1 W X 42 H.

DIMENSIONS ARE IN INCHES.  
DATE DRAWN: 2017/09/14



**HUSSmann®**

H SERIES LARGE  
OUTDOOR STD BASE

DOC PD-00000015 REV B

INFORMATION SUBJECT TO CHANGE

SHEET 2 OF 3

SWN10 SUBMITTAL SHEET SIZE D

**MINIMUM CLEARANCE REQUIREMENTS:**

ACTUAL CLEARANCE REQUIREMENTS ARE DEPENDENT UPON AUTHORITY HAVING JURISDICTION, AND MAY EXCEED DIMENSIONS SHOWN.

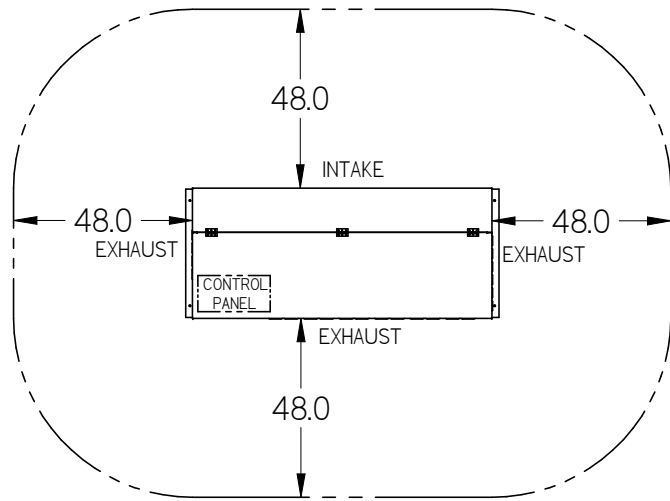

**CLEARANCE ON A SINGLE UNIT APPLICATION**

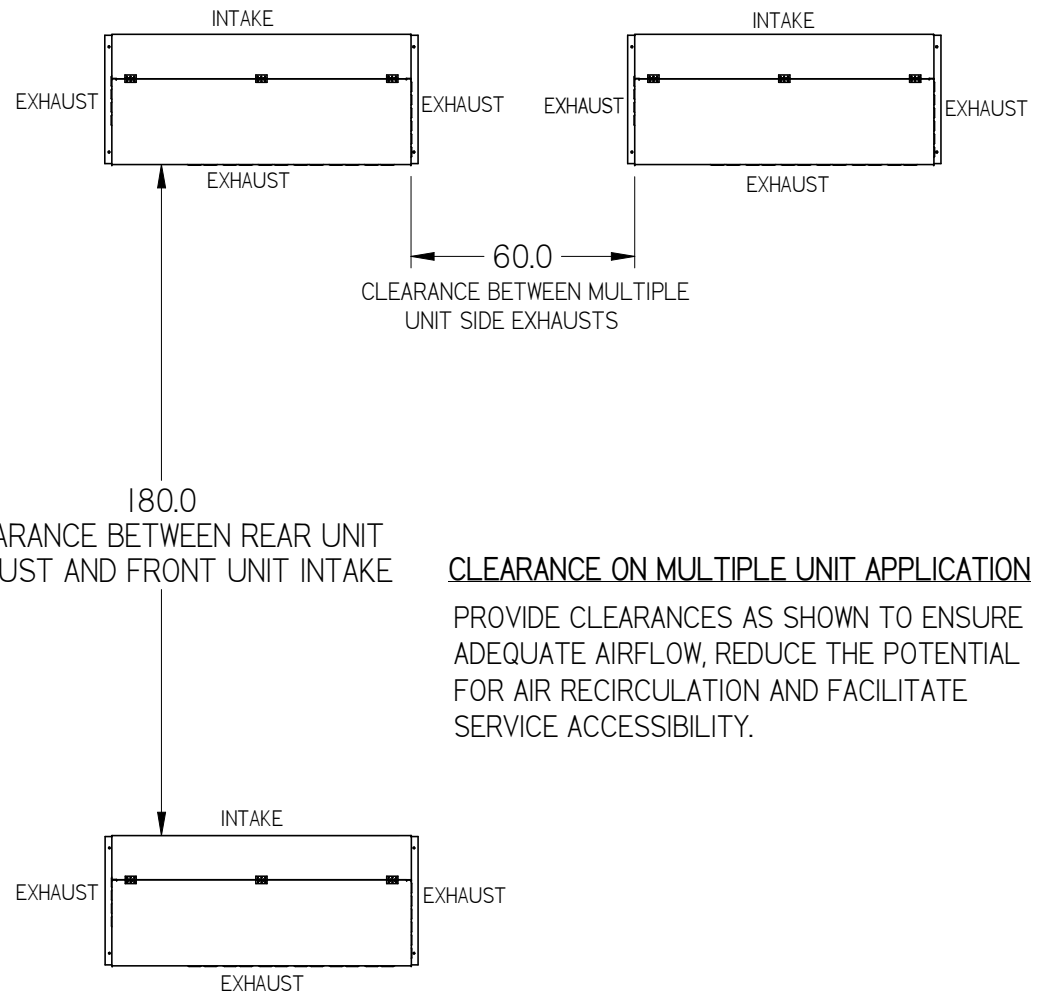

**CLEARANCE ON MULTIPLE UNIT APPLICATION**

PROVIDE CLEARANCES AS SHOWN TO ENSURE ADEQUATE AIRFLOW, REDUCE THE POTENTIAL FOR AIR RECIRCULATION AND FACILITATE SERVICE ACCESSIBILITY.

**NOTES:**

1. IT IS THE RESPONSIBILITY OF THE INSTALLING CONTRACTOR TO ENSURE THAT THE FINAL EQUIPMENT INSTALLATION MEETS ALL APPLICABLE CODE REQUIREMENTS.
2. ILLUSTRATION SHOWN IS FOR GENERAL REPRESENTATION ONLY. ACTUAL PRODUCT WILL VARY DEPENDENT UPON APPLICATION.
3. OVERALL DIMENSIONS: 88 L X 35.1 W X 42 H.

DIMENSIONS ARE IN INCHES.  
DATE DRAWN: 2017/09/14

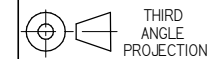

**HUSSmann®**

H SERIES LARGE  
OUTDOOR STD BASE

DOC PD-00000015 REV B

INFORMATION SUBJECT TO CHANGE

SHEET 3 OF 3

SHEET SIZE D