

**MEDIUM SIZE
INDOOR UNIT
HEAVY DUTY BASE
"HNHx-xxxxxxx-xx-A"
WEIGHT: 650 LBS.**

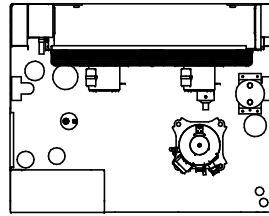

TOP VIEW

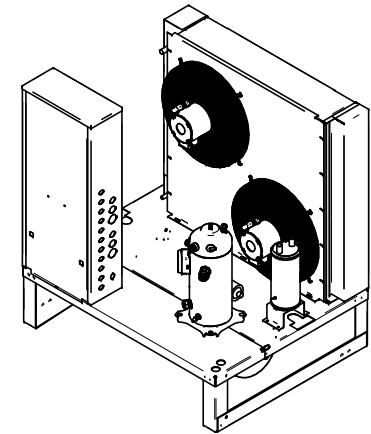

ISO VIEW

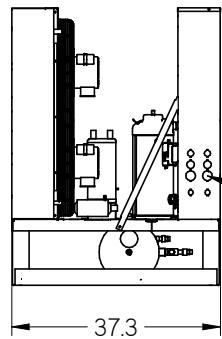

MAIN
ELECTRICAL
CONNECTION

LEFT SIDE VIEW

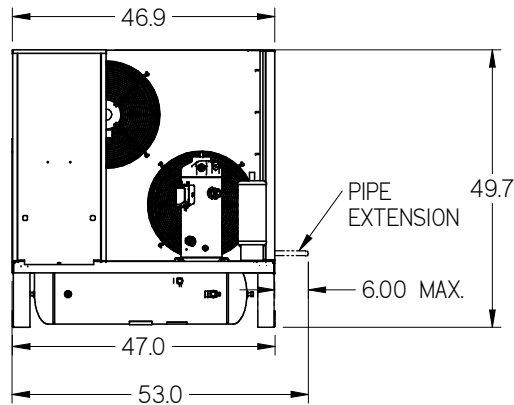

FRONT VIEW

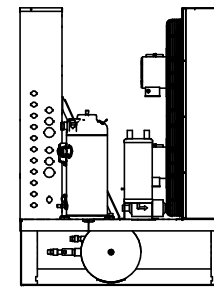

RIGHT SIDE VIEW

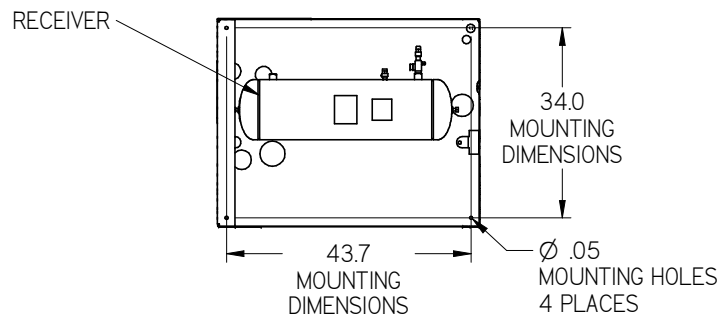

BOTTOM VIEW

NOTES:

1. IT IS THE RESPONSIBILITY OF THE INSTALLING CONTRACTOR TO ENSURE THAT THE FINAL EQUIPMENT INSTALLATION MEETS ALL APPLICABLE CODE REQUIREMENTS.
2. ILLUSTRATION SHOWN IS FOR GENERAL REPRESENTATION ONLY. ACTUAL PRODUCT WILL VARY DEPENDENT UPON APPLICATION.
3. OVERALL DIMENSIONS: 53 L X 37.3 W X 49.7 H.

DIMENSIONS ARE IN INCHES. DATE DRAWN: 2017/09/14		HUSSmann®	
 THIRD ANGLE PROJECTION		H SERIES MEDIUM INDOOR HD BASE	
		DOC PD-00000010	REV B

INFORMATION SUBJECT TO CHANGE

SHEET 1 OF 3

SWIN10 SUBMITTAL SHEET SIZE D

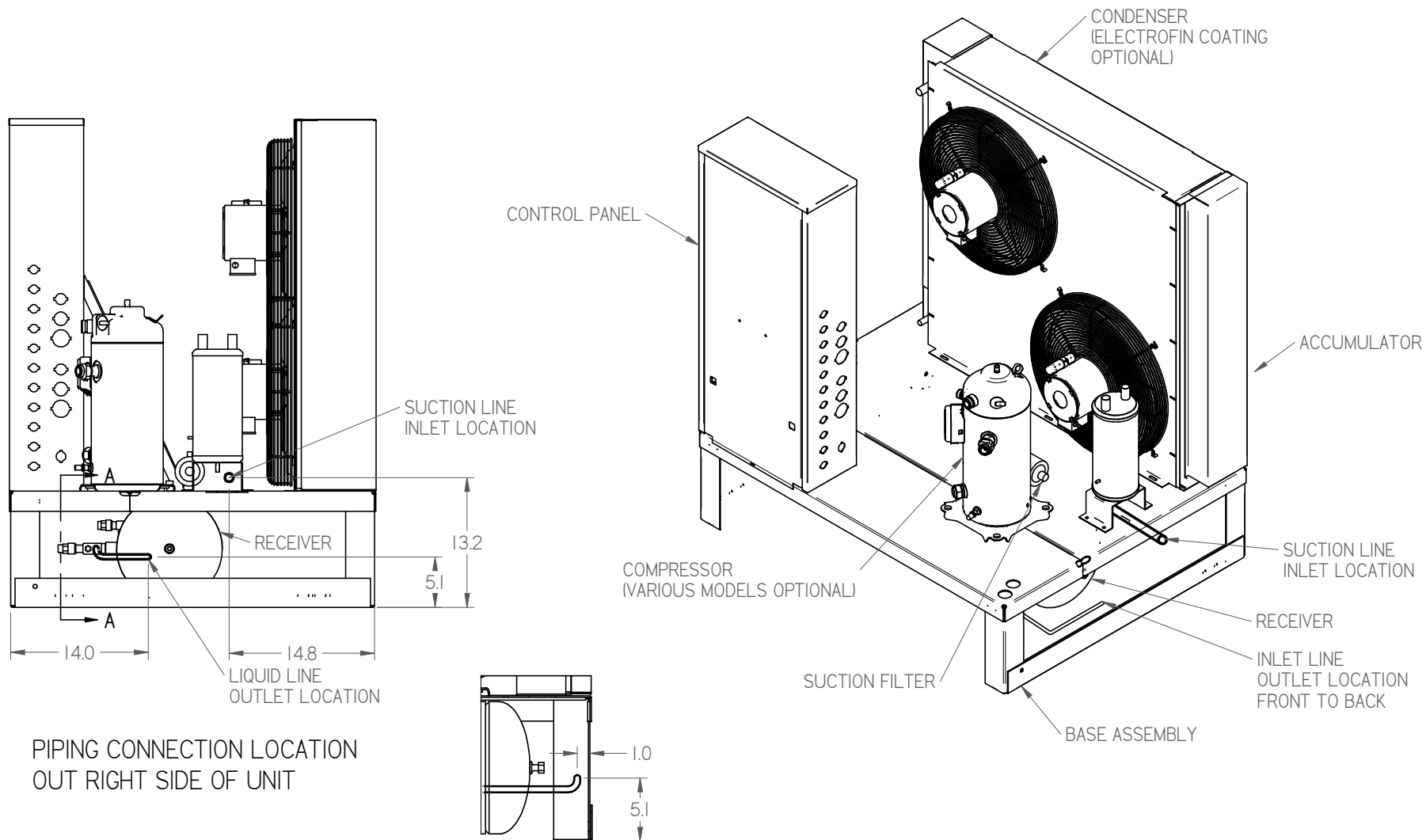

PIPING CONNECTION LOCATION
OUT RIGHT SIDE OF UNIT

SECTION A-A

NOTES:

1. IT IS THE RESPONSIBILITY OF THE INSTALLING CONTRACTOR TO ENSURE THAT THE FINAL EQUIPMENT INSTALLATION MEETS ALL APPLICABLE CODE REQUIREMENTS.
2. ILLUSTRATION SHOWN IS FOR GENERAL REPRESENTATION ONLY. ACTUAL PRODUCT WILL VARY DEPENDENT UPON APPLICATION.
3. OVERALL DIMENSIONS: 53 L X 37.3 W X 49.7 H.

DIMENSIONS ARE IN INCHES.
DATE DRAWN: 2017/09/14



HUSSmann®

H SERIES MEDIUM
INDOOR HD BASE

INFORMATION SUBJECT TO CHANGE

SHEET 2 OF 3

DOC PD-00000010 REV B

5/31/10 SUBMITTAL SHEET SIZE D

MINIMUM CLEARANCE REQUIREMENTS:

ACTUAL CLEARANCE REQUIREMENTS ARE DEPENDENT UPON AUTHORITY HAVING JURISDICTION, AND MAY EXCEED DIMENSIONS SHOWN.

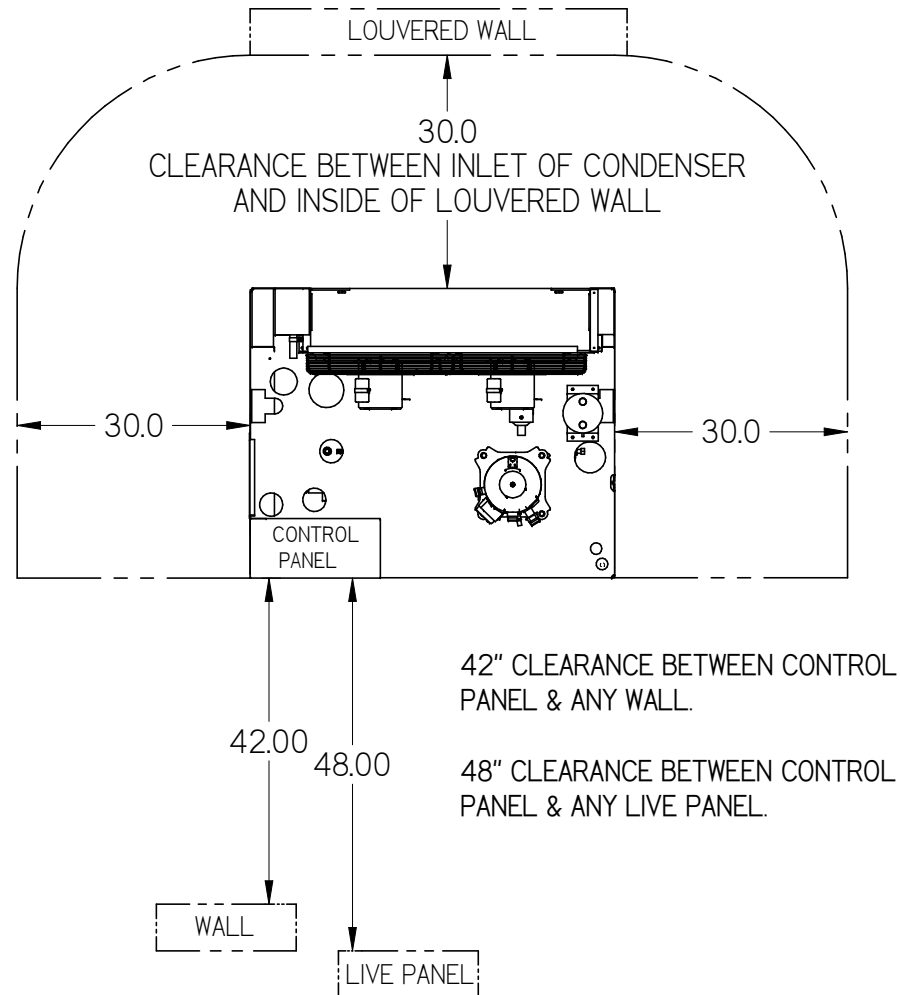

NOTES:

1. IT IS THE RESPONSIBILITY OF THE INSTALLING CONTRACTOR TO ENSURE THAT THE FINAL EQUIPMENT INSTALLATION MEETS ALL APPLICABLE CODE REQUIREMENTS.
2. ILLUSTRATION SHOWN IS FOR GENERAL REPRESENTATION ONLY. ACTUAL PRODUCT WILL VARY DEPENDENT UPON APPLICATION.
3. OVERALL DIMENSIONS: 53 L X 37.3 W X 49.7 H.

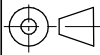
DIMENSIONS ARE IN INCHES. DATE DRAWN: 2017/09/14  THIRD ANGLE PROJECTION	HUSSmann®	
	H SERIES MEDIUM INDOOR HD BASE	
INFORMATION SUBJECT TO CHANGE	SHEET 3 OF 3	DOC PD-00000010 REV B

SHEET SIZE D SUBMITTAL