

**MEDIUM SIZE
OUTDOOR UNIT
HEAVY DUTY BASE
"HTHx-xxxxxxx-xx-A"
WEIGHT: 650 LBS.**

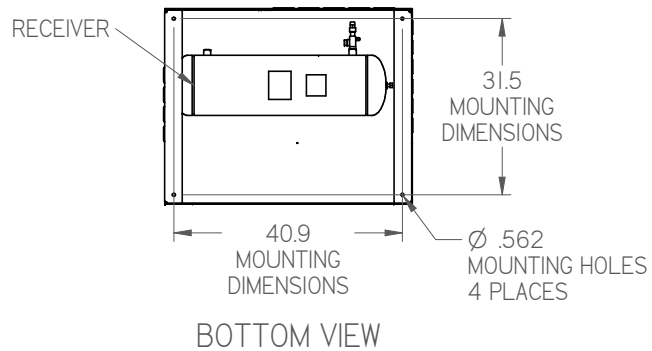

- NOTES:
1. IT IS THE RESPONSIBILITY OF THE INSTALLING CONTRACTOR TO ENSURE THAT THE FINAL EQUIPMENT INSTALLATION MEETS ALL APPLICABLE CODE REQUIREMENTS.
2. ILLUSTRATION SHOWN IS FOR GENERAL REPRESENTATION ONLY. ACTUAL PRODUCT WILL VARY DEPENDENT UPON APPLICATION.
3. OVERALL DIMENSIONS: 50.3 L X 35 W X 49.7 H.

DIMENSIONS ARE IN INCHES. DATE DRAWN: 2017/09/14	HUSSmann®
THIRD ANGLE PROJECTION	H SERIES MEDIUM OUTDOOR HD BASE
INFORMATION SUBJECT TO CHANGE	DOC PD-00000018 REV B
SHEET 1 OF 3	

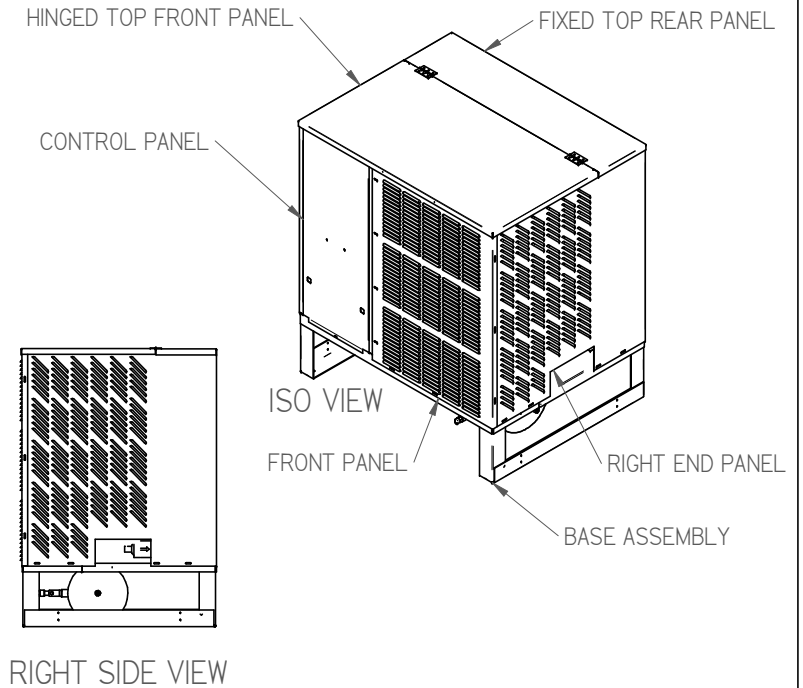
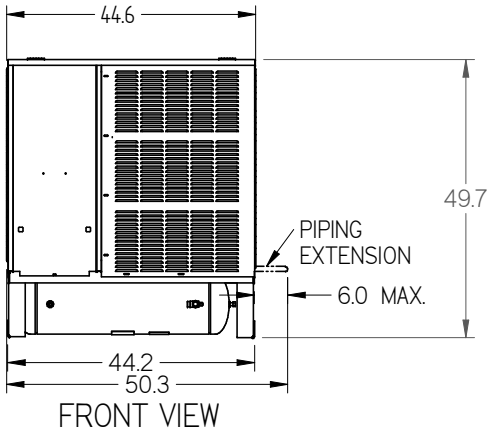
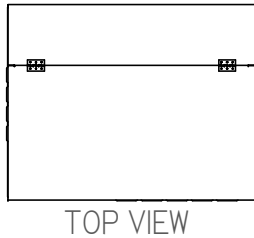
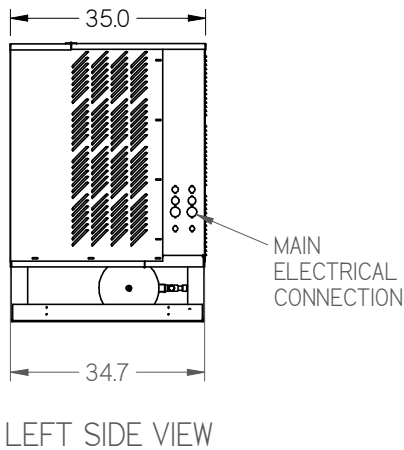
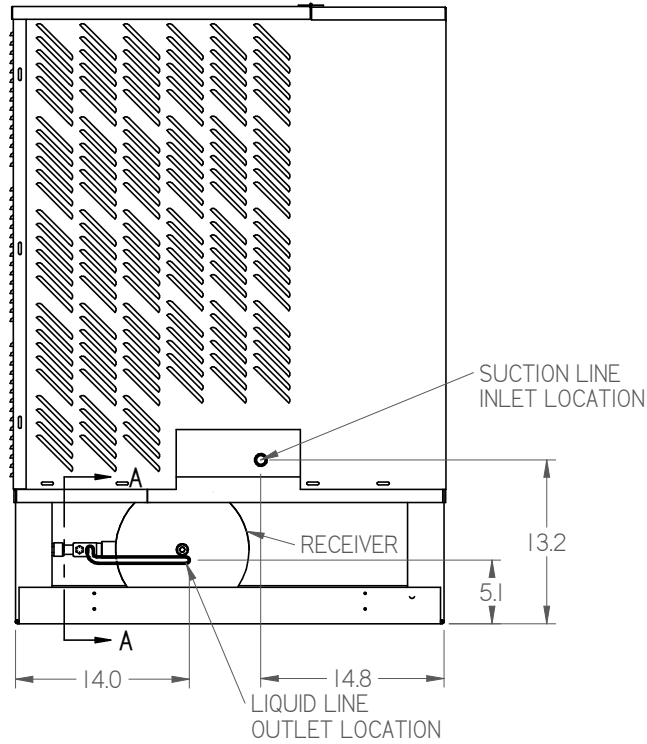

PIPING CONNECTION LOCATION
OUT RIGHT SIDE OF UNIT

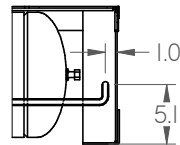

SECTION A-A

CONTROL PANEL

COMPRESSOR
(VARIOUS MODELS OPTIONAL)

ISO VIEW WITH OUTDOOR HOUSING
REMOVED FOR CLARITY

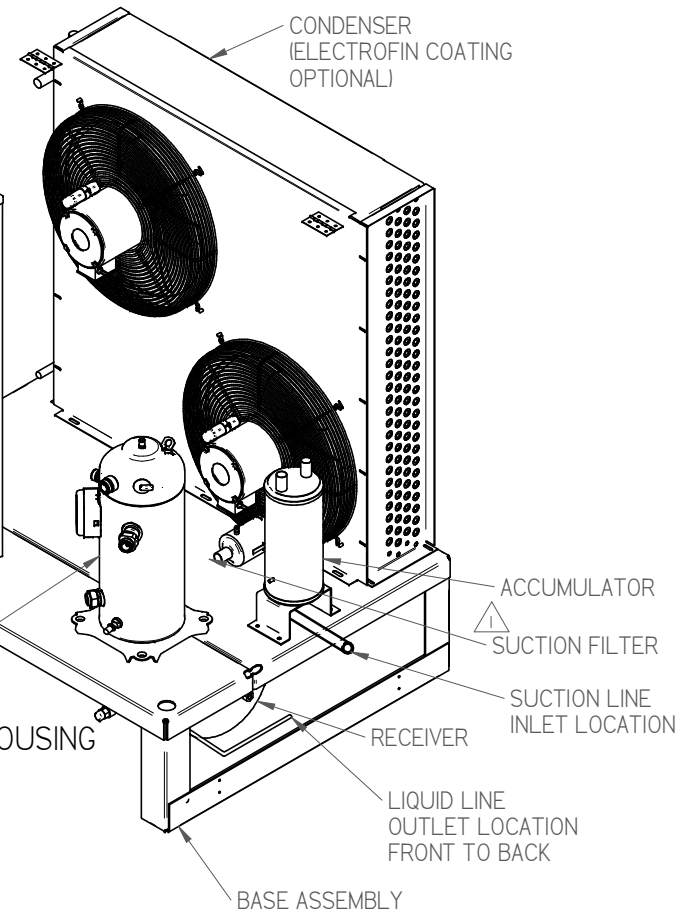

NOTES:

1. IT IS THE RESPONSIBILITY OF THE INSTALLING CONTRACTOR TO ENSURE THAT THE FINAL EQUIPMENT INSTALLATION MEETS ALL APPLICABLE CODE REQUIREMENTS.
2. ILLUSTRATION SHOWN IS FOR GENERAL REPRESENTATION ONLY. ACTUAL PRODUCT WILL VARY DEPENDENT UPON APPLICATION.
3. OVERALL DIMENSIONS: 50.3 L X 35 W X 49.7 H.

DIMENSIONS ARE IN INCHES.
DATE DRAWN: 2017/09/14



HUSSmann®

H SERIES MEDIUM
OUTDOOR HD BASE

INFORMATION SUBJECT TO CHANGE

SHEET 2 OF 3

DOC PD-00000018 REV B

SHEET 10 SUBMITTAL SHEET SIZE D

MINIMUM CLEARANCE REQUIREMENTS:

ACTUAL CLEARANCE REQUIREMENTS ARE DEPENDENT UPON AUTHORITY HAVING JURISDICTION, AND MAY EXCEED DIMENSIONS SHOWN.

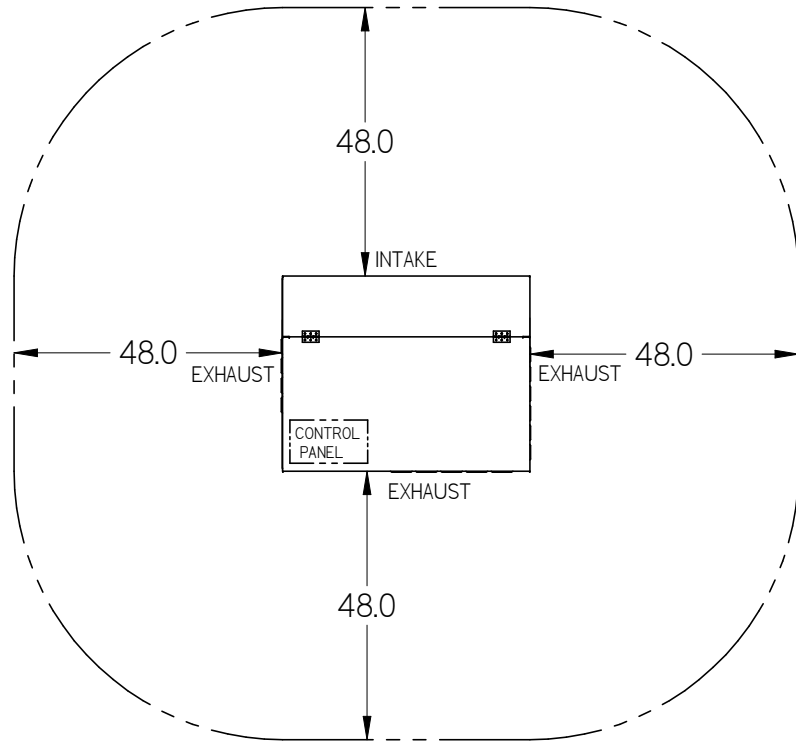

CLEARANCE ON A SINGLE UNIT APPLICATION

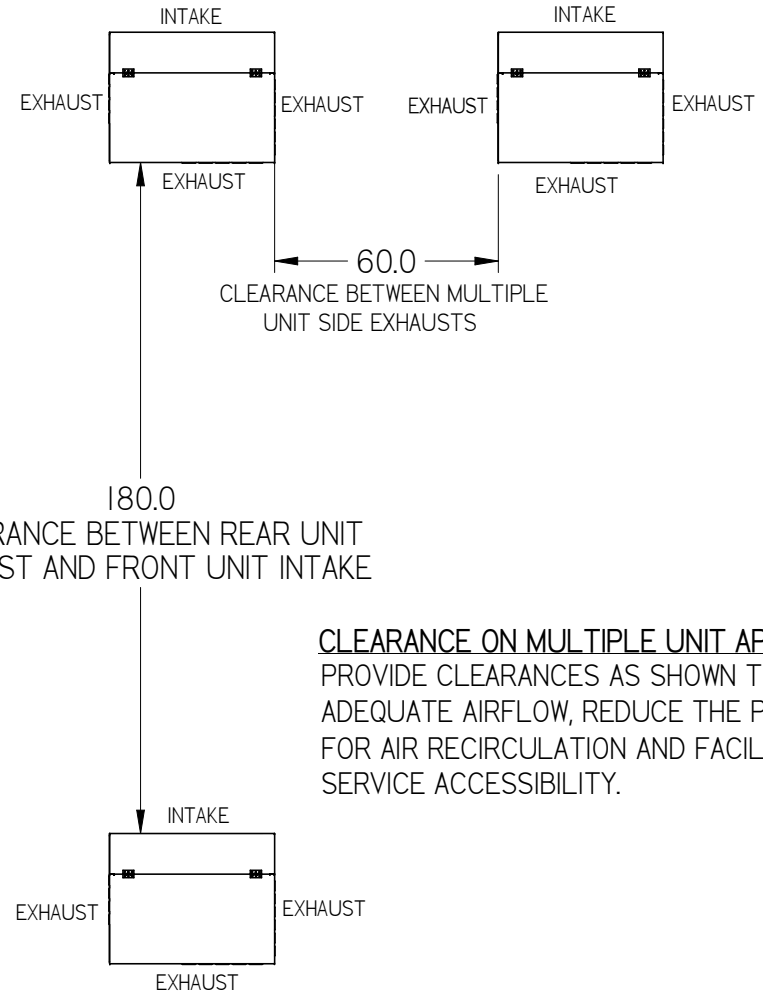

CLEARANCE ON MULTIPLE UNIT APPLICATION
 PROVIDE CLEARANCES AS SHOWN TO ENSURE ADEQUATE AIRFLOW, REDUCE THE POTENTIAL FOR AIR RECIRCULATION AND FACILITATE SERVICE ACCESSIBILITY.

NOTES:

1. IT IS THE RESPONSIBILITY OF THE INSTALLING CONTRACTOR TO ENSURE THAT THE FINAL EQUIPMENT INSTALLATION MEETS ALL APPLICABLE CODE REQUIREMENTS.
2. ILLUSTRATION SHOWN IS FOR GENERAL REPRESENTATION ONLY. ACTUAL PRODUCT WILL VARY DEPENDENT UPON APPLICATION.
3. OVERALL DIMENSIONS: 50.3 L X 35 W X 49.7 H.

DIMENSIONS ARE IN INCHES.
 DATE DRAWN: 2017/09/14



THIRD
 ANGLE
 PROJECTION

HUSSmann®

H SERIES MEDIUM
 OUTDOOR HD BASE

INFORMATION SUBJECT TO CHANGE

SHEET 3 OF 3

DOC PD-000000018 REV B

SMN10 SUBMITTAL SHEET SIZE D