

**SMALL SIZE
OUTDOOR UNIT
HEAVY DUTY BASE
"HTHx-xxxxxxx-xx-A"
WEIGHT: 400 LBS.**

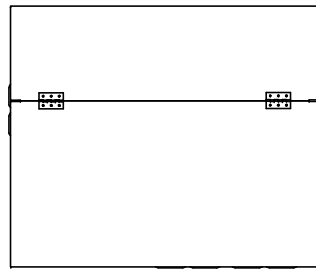

TOP VIEW

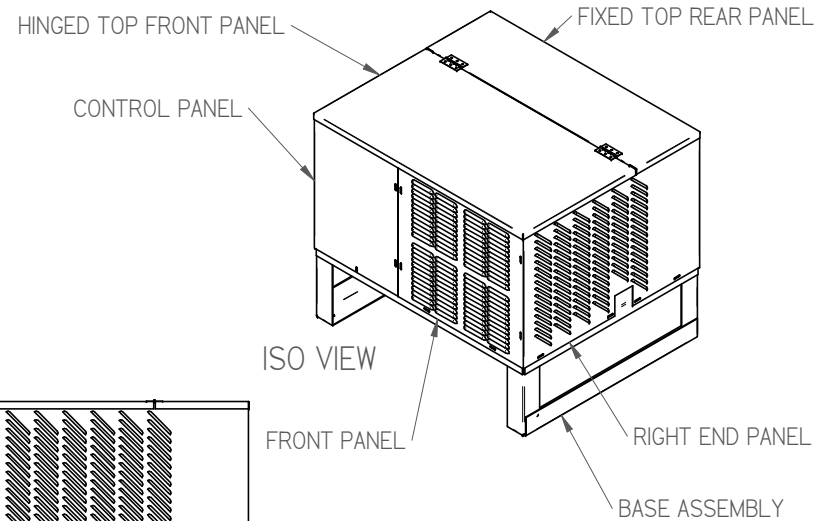

ISO VIEW

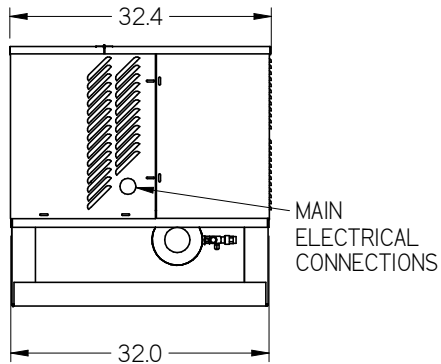

LEFT SIDE VIEW

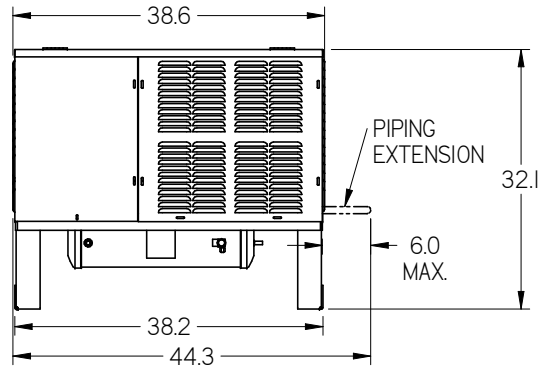

FRONT VIEW

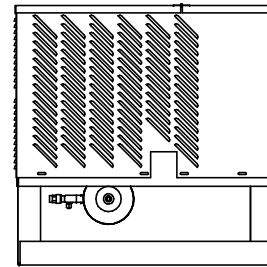

RIGHT SIDE VIEW

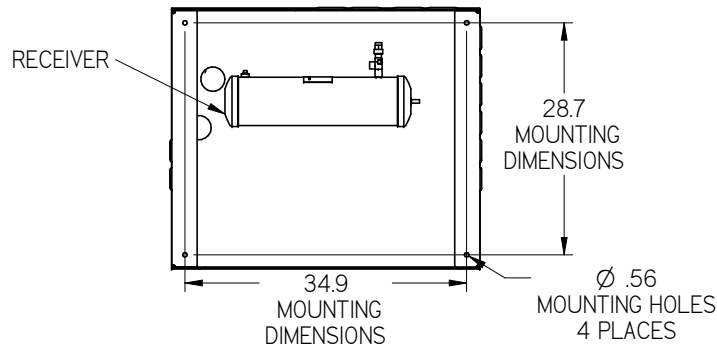

BOTTOM VIEW

NOTES:

1. IT IS THE RESPONSIBILITY OF THE INSTALLING CONTRACTOR TO ENSURE THAT THE FINAL EQUIPMENT INSTALLATION MEETS ALL APPLICABLE CODE REQUIREMENTS.
2. ILLUSTRATION SHOWN IS FOR GENERAL REPRESENTATION ONLY. ACTUAL PRODUCT WILL VARY DEPENDENT UPON APPLICATION.
3. OVERALL DIMENSIONS: 44.3 L X 32.4 W X 32.1 H.

DIMENSIONS ARE IN INCHES.
DATE DRAWN: 2017/09/14



THIRD
ANGLE
PROJECTION

HUSSMANN®

H SERIES SMALL
OUTDOOR HD BASE

DOC PD-00000017 REV B

INFORMATION SUBJECT TO CHANGE

SHEET 1 OF 3

SHEET SUBMITTAL SHEET SIZE D

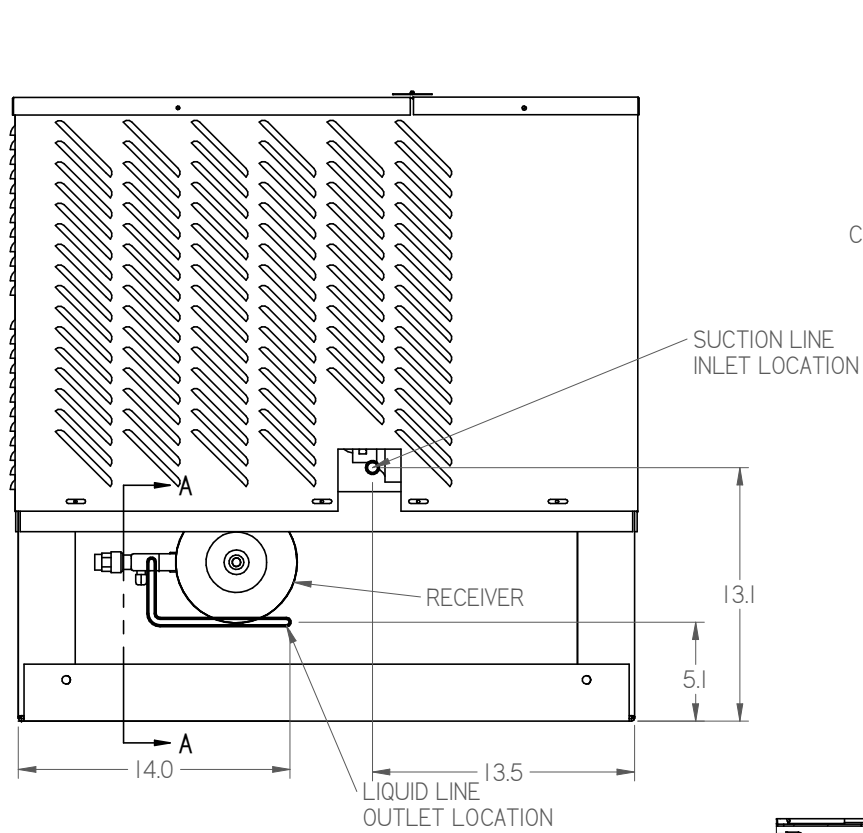

PIPING CONNECTION LOCATION
OUT RIGHT SIDE OF UNIT

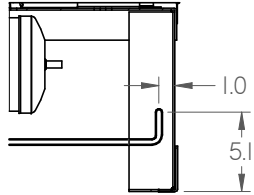

SECTION A-A

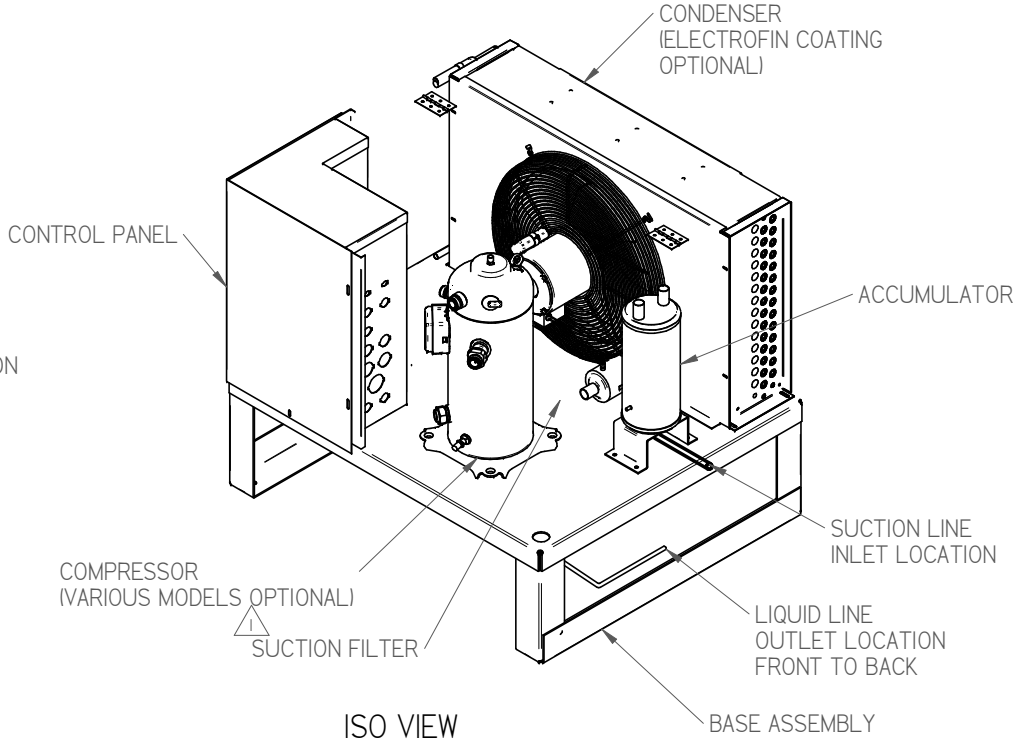

ISO VIEW
OUTDOOR HOUSING
REMOVED FOR CLARITY

- NOTES:
1. IT IS THE RESPONSIBILITY OF THE INSTALLING CONTRACTOR TO ENSURE THAT THE FINAL EQUIPMENT INSTALLATION MEETS ALL APPLICABLE CODE REQUIREMENTS.
 2. ILLUSTRATION SHOWN IS FOR GENERAL REPRESENTATION ONLY. ACTUAL PRODUCT WILL VARY DEPENDENT UPON APPLICATION.
 3. OVERALL DIMENSIONS: 44.3 L X 32.4 W X 32.1 H.

DIMENSIONS ARE IN INCHES.
DATE DRAWN: 2017/09/14



HUSSmann®

H SERIES SMALL
OUTDOOR HD BASE

INFORMATION SUBJECT TO CHANGE

SHEET 2 OF 3

DOC PD-00000017 REV B

SMN10 SUBMITTAL SHEET SIZE D

MINIMUM CLEARANCE REQUIREMENTS:

ACTUAL CLEARANCE REQUIREMENTS ARE DEPENDENT UPON AUTHORITY HAVING JURISDICTION, AND MAY EXCEED DIMENSIONS SHOWN.

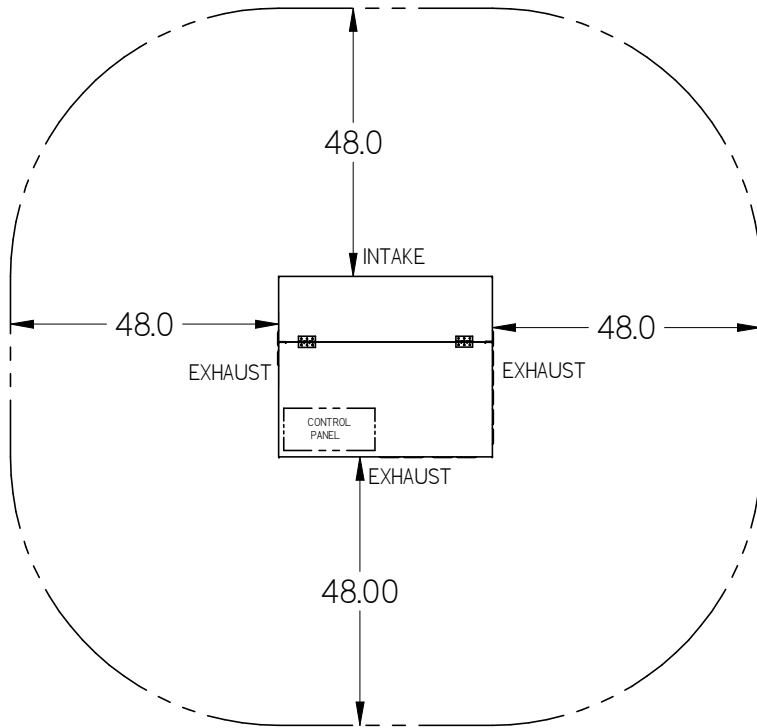

CLEARANCE ON A SINGLE UNIT APPLICATION

NOTES:

1. IT IS THE RESPONSIBILITY OF THE INSTALLING CONTRACTOR TO ENSURE THAT THE FINAL EQUIPMENT INSTALLATION MEETS ALL APPLICABLE CODE REQUIREMENTS.
2. ILLUSTRATION SHOWN IS FOR GENERAL REPRESENTATION ONLY. ACTUAL PRODUCT WILL VARY DEPENDENT UPON APPLICATION.
3. OVERALL DIMENSIONS: 44.3 L X 32.4 W X 32.1 H.

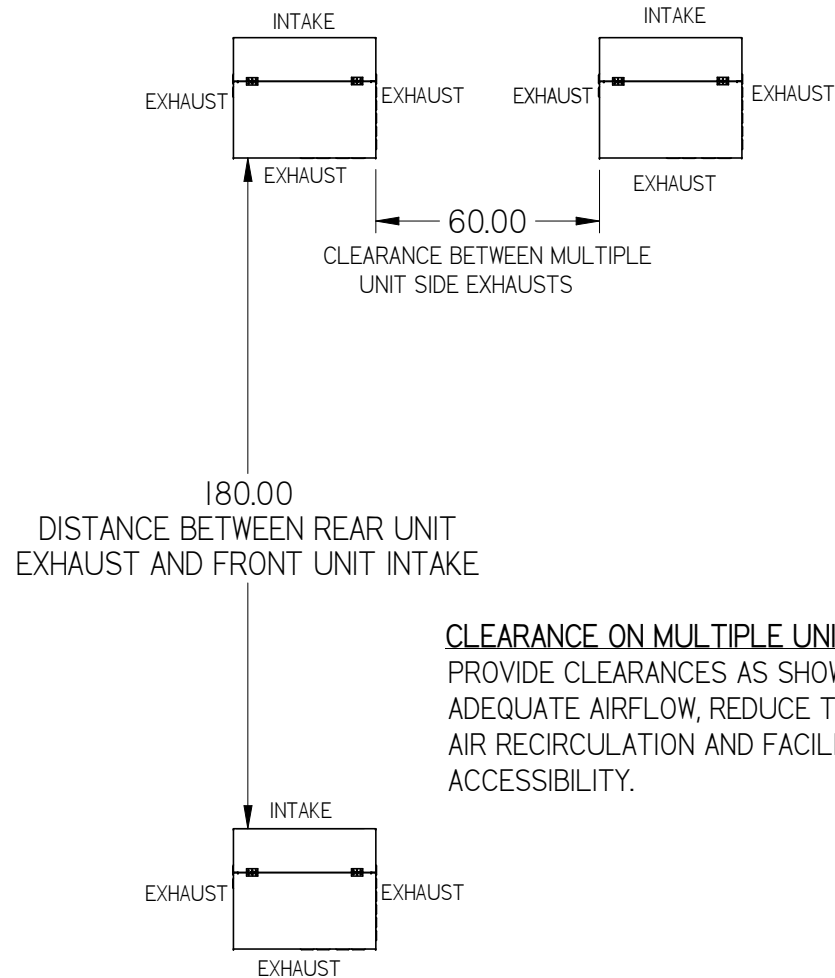

60.00
CLEARANCE BETWEEN MULTIPLE UNIT SIDE EXHAUSTS

180.00
DISTANCE BETWEEN REAR UNIT EXHAUST AND FRONT UNIT INTAKE

CLEARANCE ON MULTIPLE UNIT APPLICATION
PROVIDE CLEARANCES AS SHOWN TO ENSURE ADEQUATE AIRFLOW, REDUCE THE POTENTIAL FOR AIR RECIRCULATION AND FACILITATE SERVICE ACCESSIBILITY.

INFORMATION SUBJECT TO CHANGE

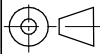
DIMENSIONS ARE IN INCHES. DATE DRAWN: 2017/09/14  THIRD ANGLE PROJECTION	HUSSmann®	
	H SERIES SMALL OUTDOOR HD BASE	
	DOC PD-00000017	REV B

SHEET 3 OF 3

SMV10 SUBMITTAL SHEET SIZE D