

**SMALL SIZE
OUTDOOR UNIT
STANDARD BASE
"HTSx-xxxxxxx-xx-A"
WEIGHT: 400 LBS.**

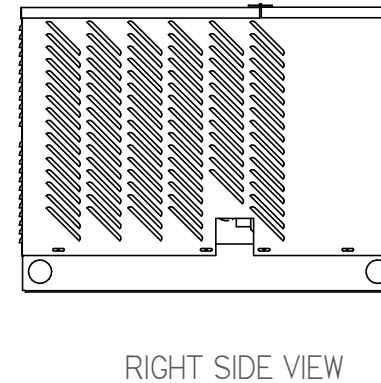
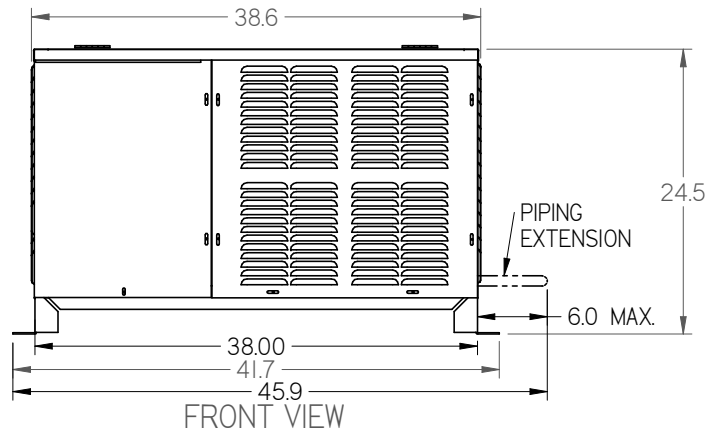
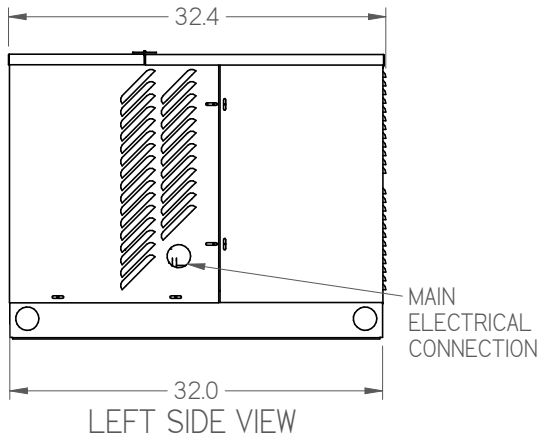
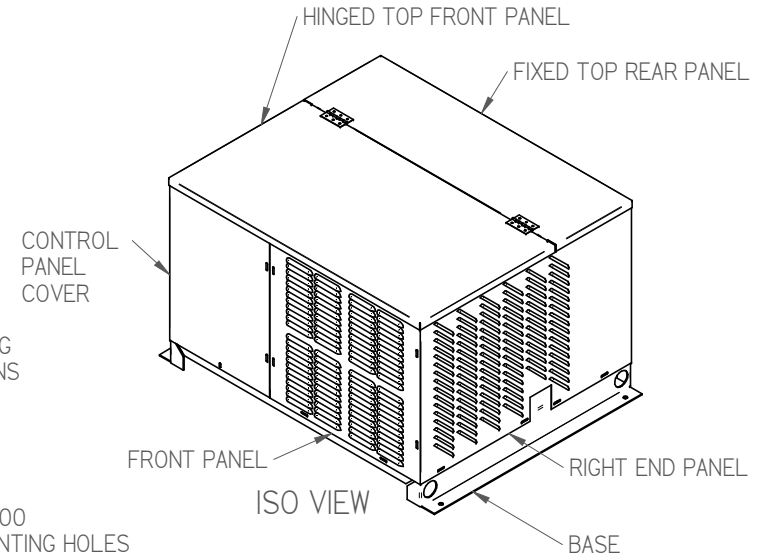
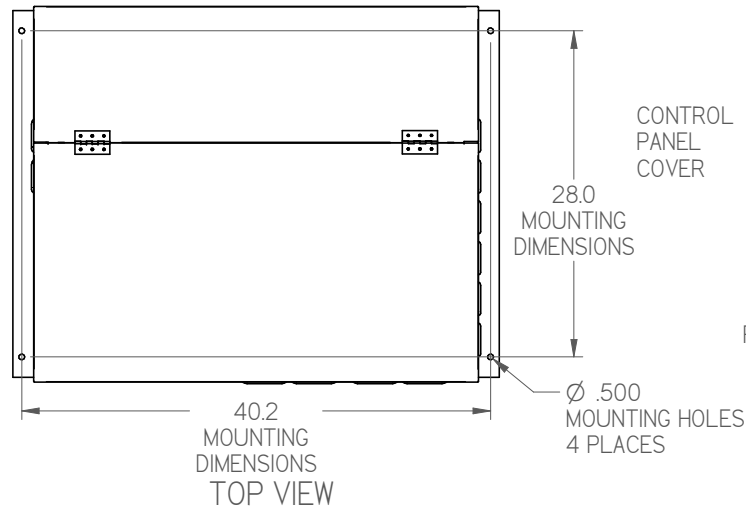

NOTES:

1. IT IS THE RESPONSIBILITY OF THE INSTALLING CONTRACTOR TO ENSURE THAT THE FINAL EQUIPMENT INSTALLATION MEETS ALL APPLICABLE CODE REQUIREMENTS.
2. ILLUSTRATION SHOWN IS FOR GENERAL REPRESENTATION ONLY. ACTUAL PRODUCT WILL VARY DEPENDENT UPON APPLICATION.
3. OVERALL DIMENSIONS: 45.9 L X 32.4 W X 24.5 H.

DIMENSIONS ARE IN INCHES.
DATE DRAWN: 2017/09/14



HUSSmann®

H SERIES SMALL
OUTDOOR STD BASE

DOC PD-00000013 REV B

INFORMATION SUBJECT TO CHANGE

SHEET 1 OF 3

SWIN10 SUBMITTAL SHEET SIZE D

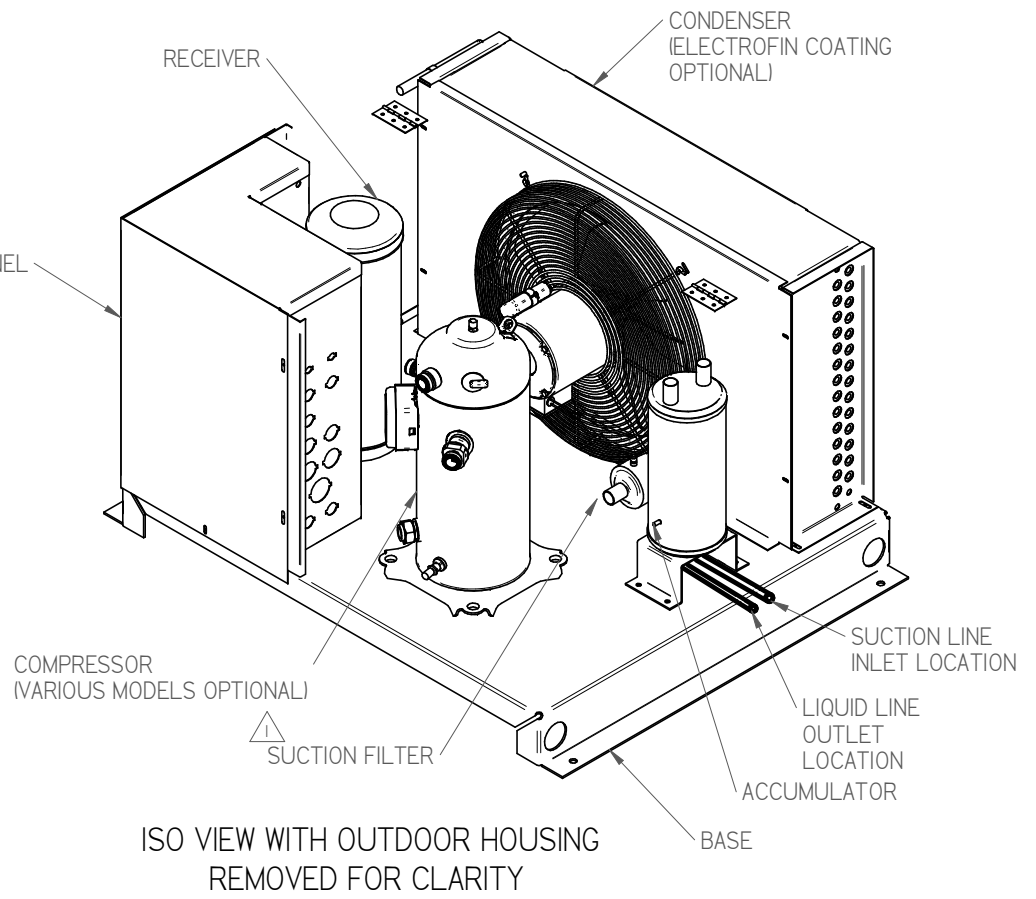
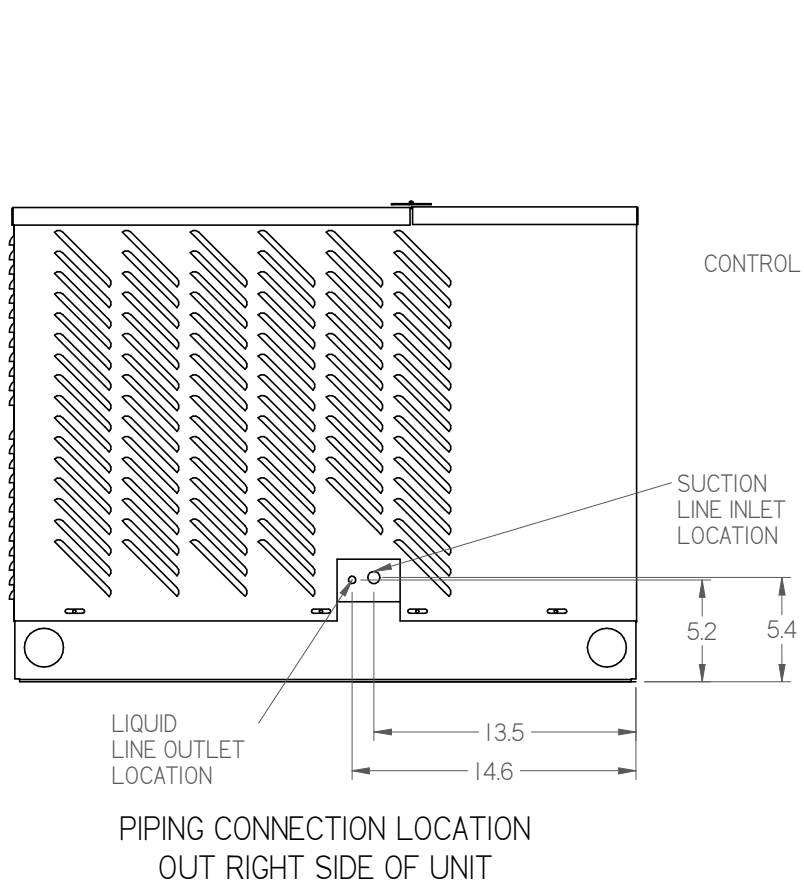

NOTES:

1. IT IS THE RESPONSIBILITY OF THE INSTALLING CONTRACTOR TO ENSURE THAT THE FINAL EQUIPMENT INSTALLATION MEETS ALL APPLICABLE CODE REQUIREMENTS.
2. ILLUSTRATION SHOWN IS FOR GENERAL REPRESENTATION ONLY. ACTUAL PRODUCT WILL VARY DEPENDENT UPON APPLICATION.
3. OVERALL DIMENSIONS: 45.9 L X 32.4 W X 24.5 H.

DIMENSIONS ARE IN INCHES.
DATE DRAWN: 2017/09/14

HUSSmann®

H SERIES SMALL
OUTDOOR STD BASE



INFORMATION SUBJECT TO CHANGE

SHEET 2 OF 3

DOC PD-000000013 REV B

5/21/10 SUBMITTAL SHEET SIZE D

MINIMUM CLEARANCE REQUIREMENTS:

ACTUAL CLEARANCE REQUIREMENTS ARE DEPENDENT UPON AUTHORITY HAVING JURISDICTION, AND MAY EXCEED DIMENSIONS SHOWN.

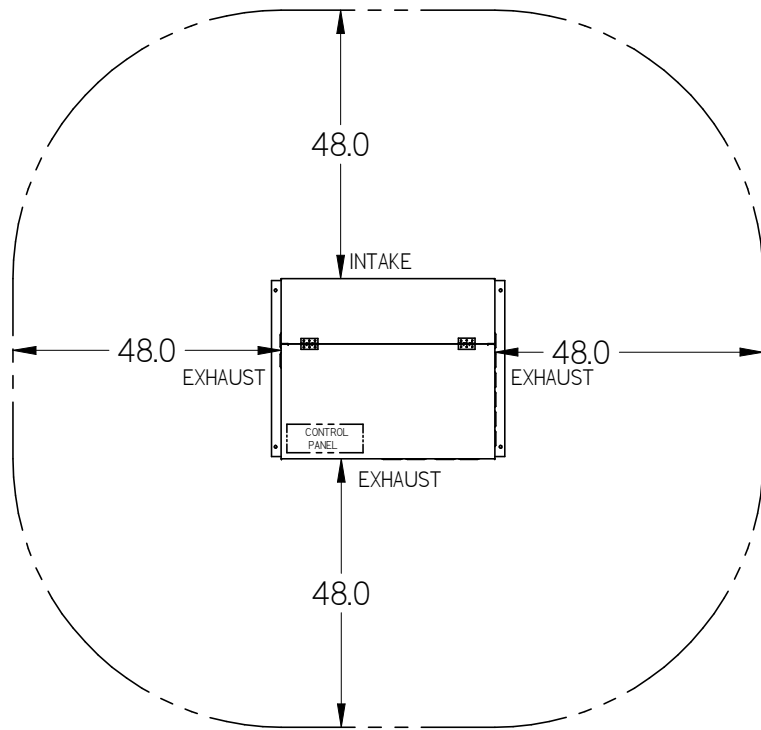

CLEARANCE ON A SINGLE UNIT APPLICATION

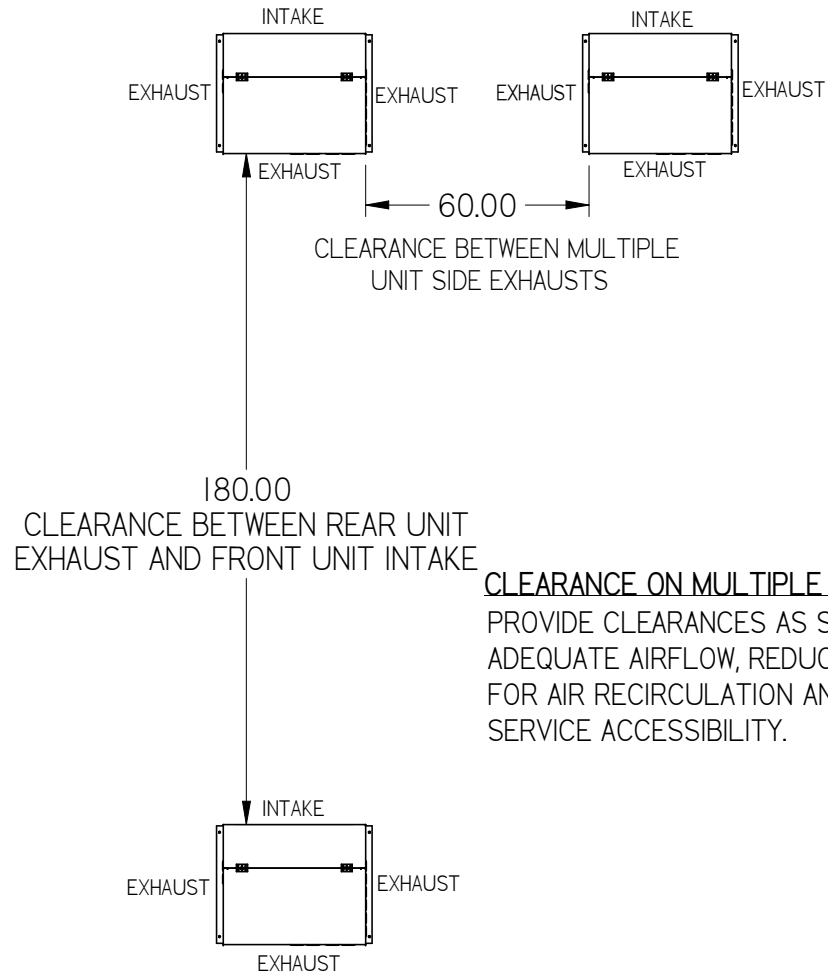

CLEARANCE ON MULTIPLE UNIT APPLICATION
 PROVIDE CLEARANCES AS SHOWN TO ENSURE ADEQUATE AIRFLOW, REDUCE THE POTENTIAL FOR AIR RECIRCULATION AND FACILITATE SERVICE ACCESSIBILITY.

NOTES:

1. IT IS THE RESPONSIBILITY OF THE INSTALLING CONTRACTOR TO ENSURE THAT THE FINAL EQUIPMENT INSTALLATION MEETS ALL APPLICABLE CODE REQUIREMENTS.
2. ILLUSTRATION SHOWN IS FOR GENERAL REPRESENTATION ONLY. ACTUAL PRODUCT WILL VARY DEPENDENT UPON APPLICATION.
3. OVERALL DIMENSIONS: 45.9 L X 32.4 W X 24.5 H.

DIMENSIONS ARE IN INCHES.
 DATE DRAWN: 2017/09/14



THIRD
 ANGLE
 PROJECTION

HUSSmann®

H SERIES SMALL
 OUTDOOR STD BASE

DOC PD-000000013 REV B

INFORMATION SUBJECT TO CHANGE

SHEET 3 OF 3

SMN10 SUBMITTAL SHEET SIZE D