

**HIGH EFFICIENCY  
H-SERIES  
MEDIUM SIZE  
OUTDOOR UNIT  
STANDARD BASE**  
"HxSx-xxxxxxx-xx-x"  
**WEIGHT: 650 LBS.**

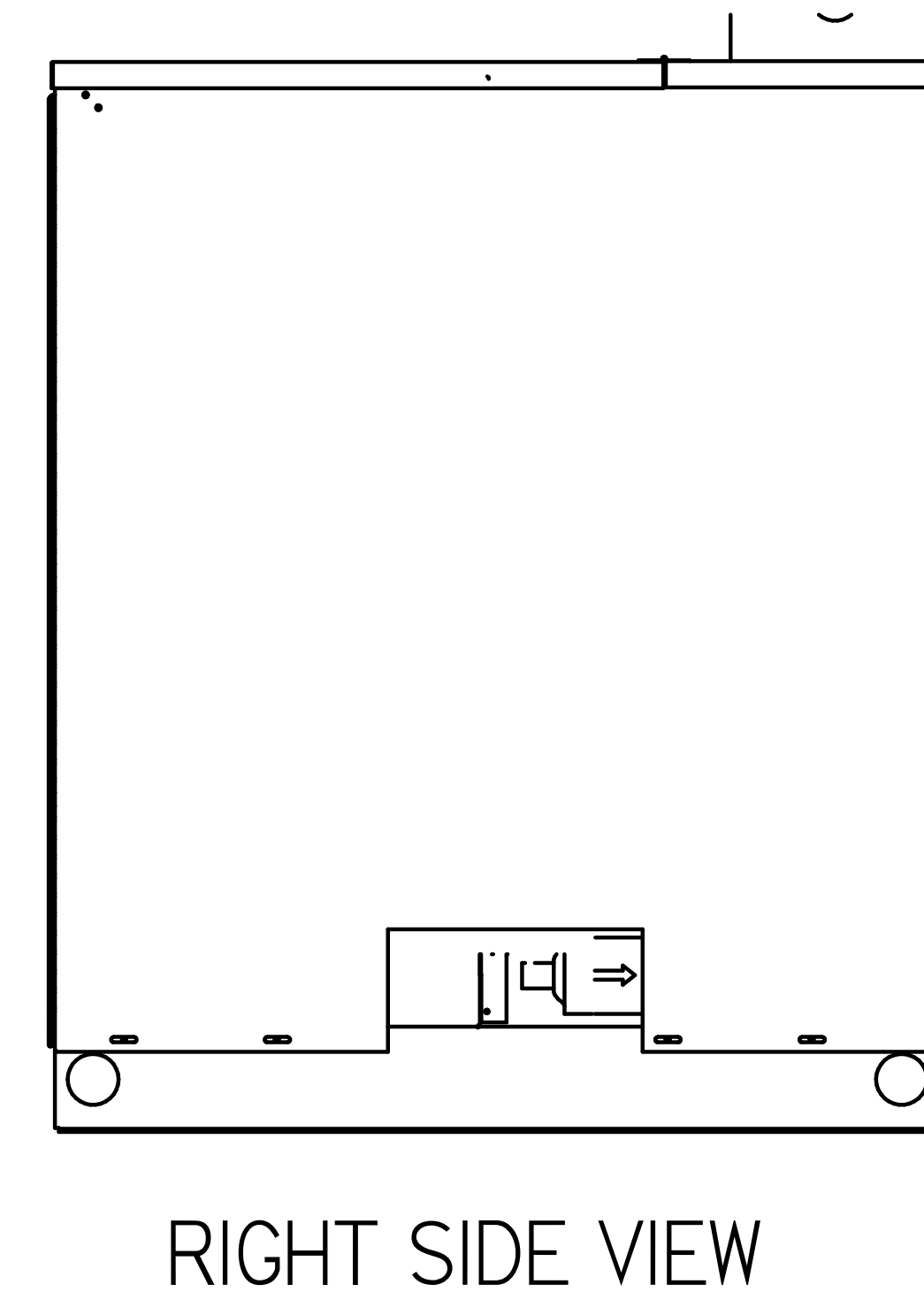
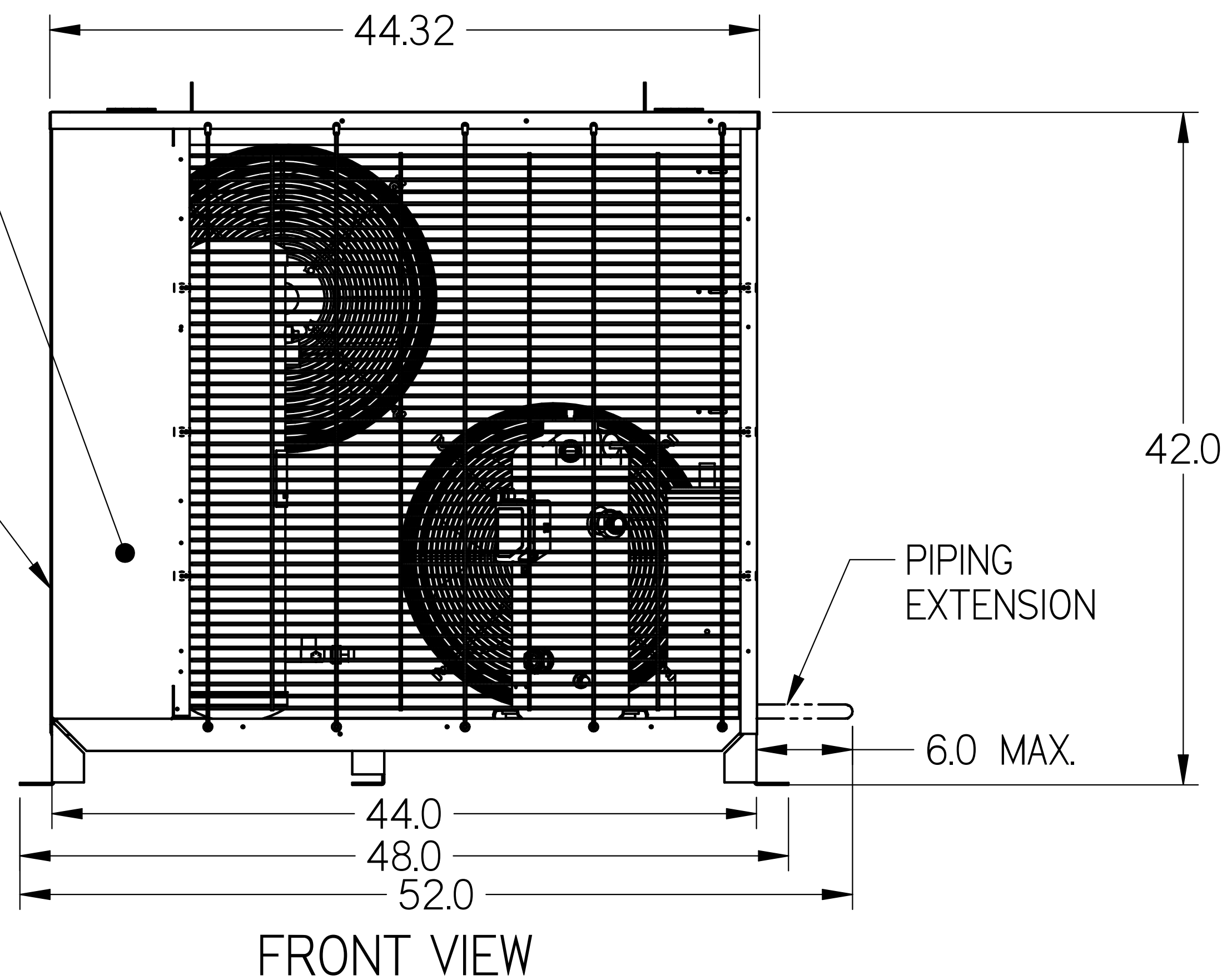
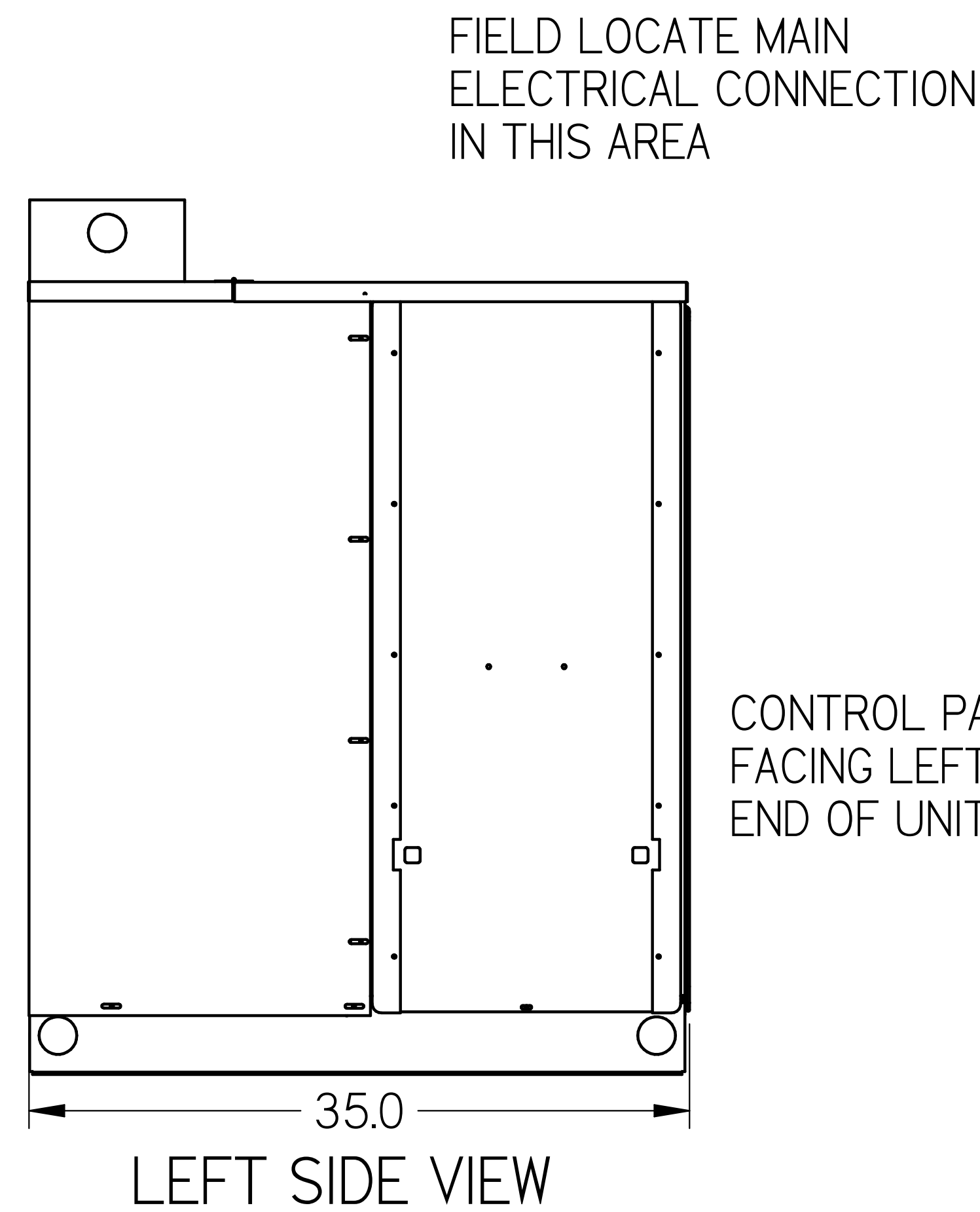
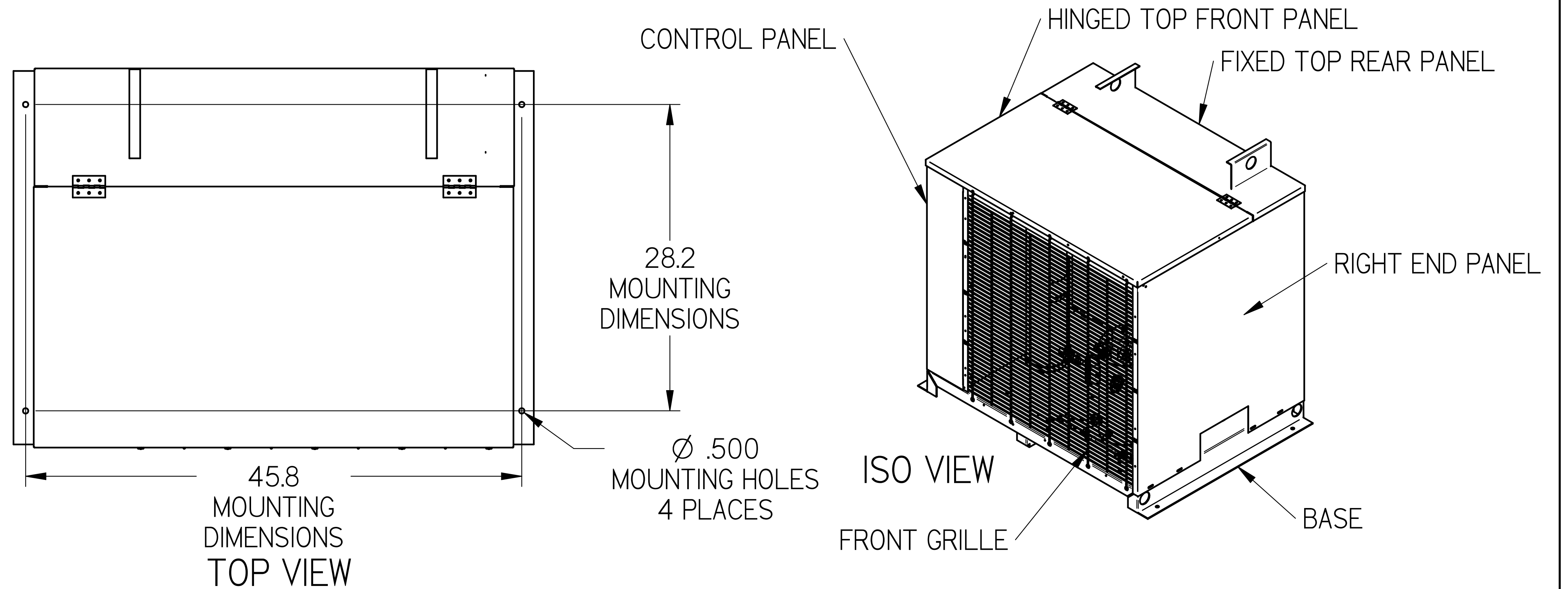

NOTES:

1. IT IS THE RESPONSIBILITY OF THE INSTALLING CONTRACTOR TO ENSURE THAT THE FINAL EQUIPMENT INSTALLATION MEETS ALL APPLICABLE CODE REQUIREMENTS.
2. ILLUSTRATION SHOWN IS FOR GENERAL REPRESENTATION ONLY. ACTUAL PRODUCT WILL VARY DEPENDENT UPON APPLICATION.
3. OVERALL DIMENSIONS: 52.0 L X 35.0 W X 42.0 H.

INFORMATION SUBJECT TO CHANGE

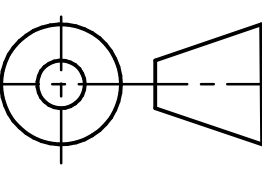
DIMENSIONS ARE IN INCHES. DATE DRAWN: 2017/09/14  THIRD ANGLE PROJECTION	<b>HUSSmann®</b>	
	HIGH EFFICIENCY H SERIES MDM OD STD BASE SIDE CTL PNL	
SHEET 1 OF 3	DOC PD-000000014	REV F

SWN 1.0 SUBMITTAL SHEET SIZE D

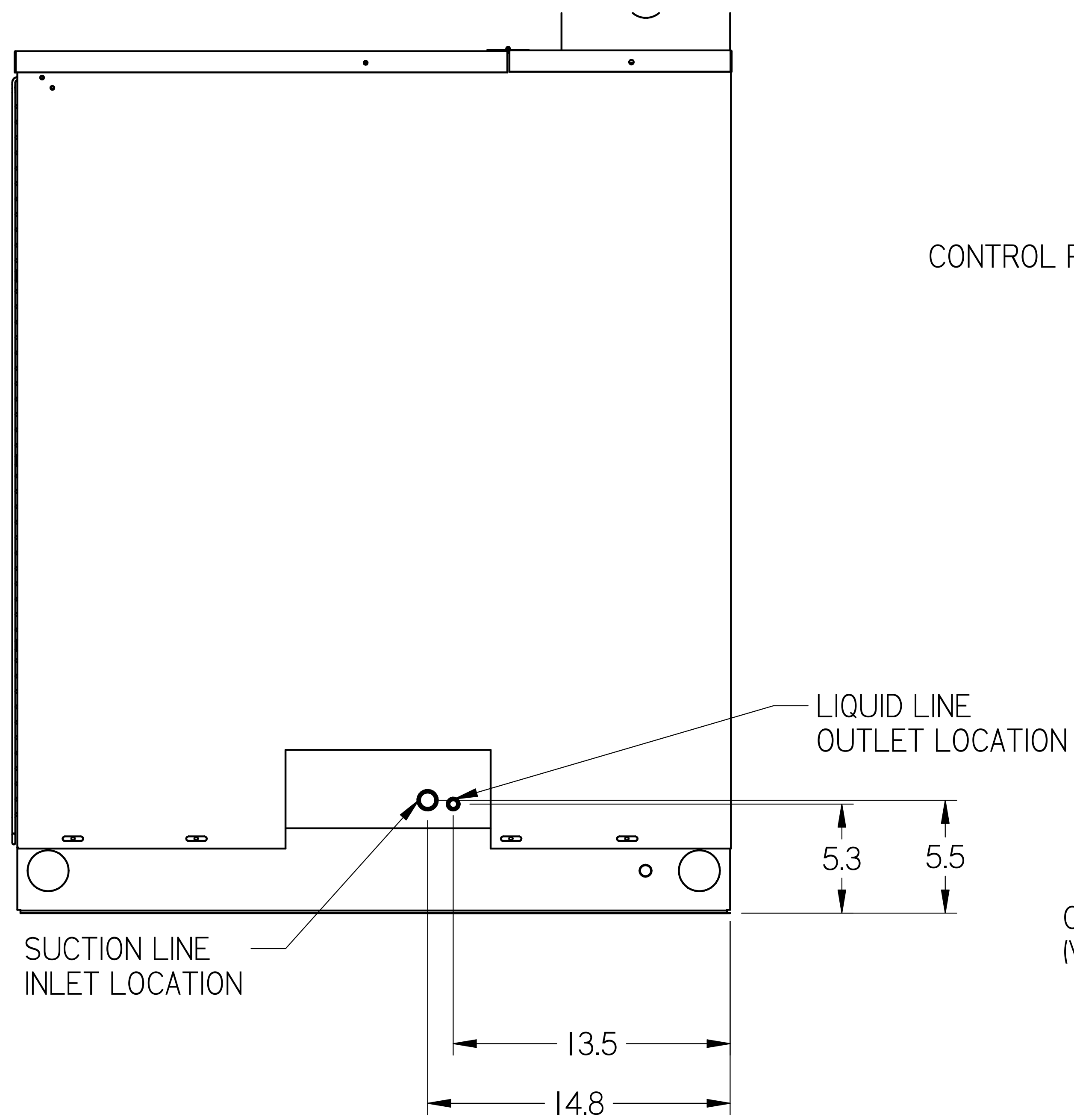

PIPING CONNECTION LOCATION  
OUT RIGHT SIDE OF UNIT

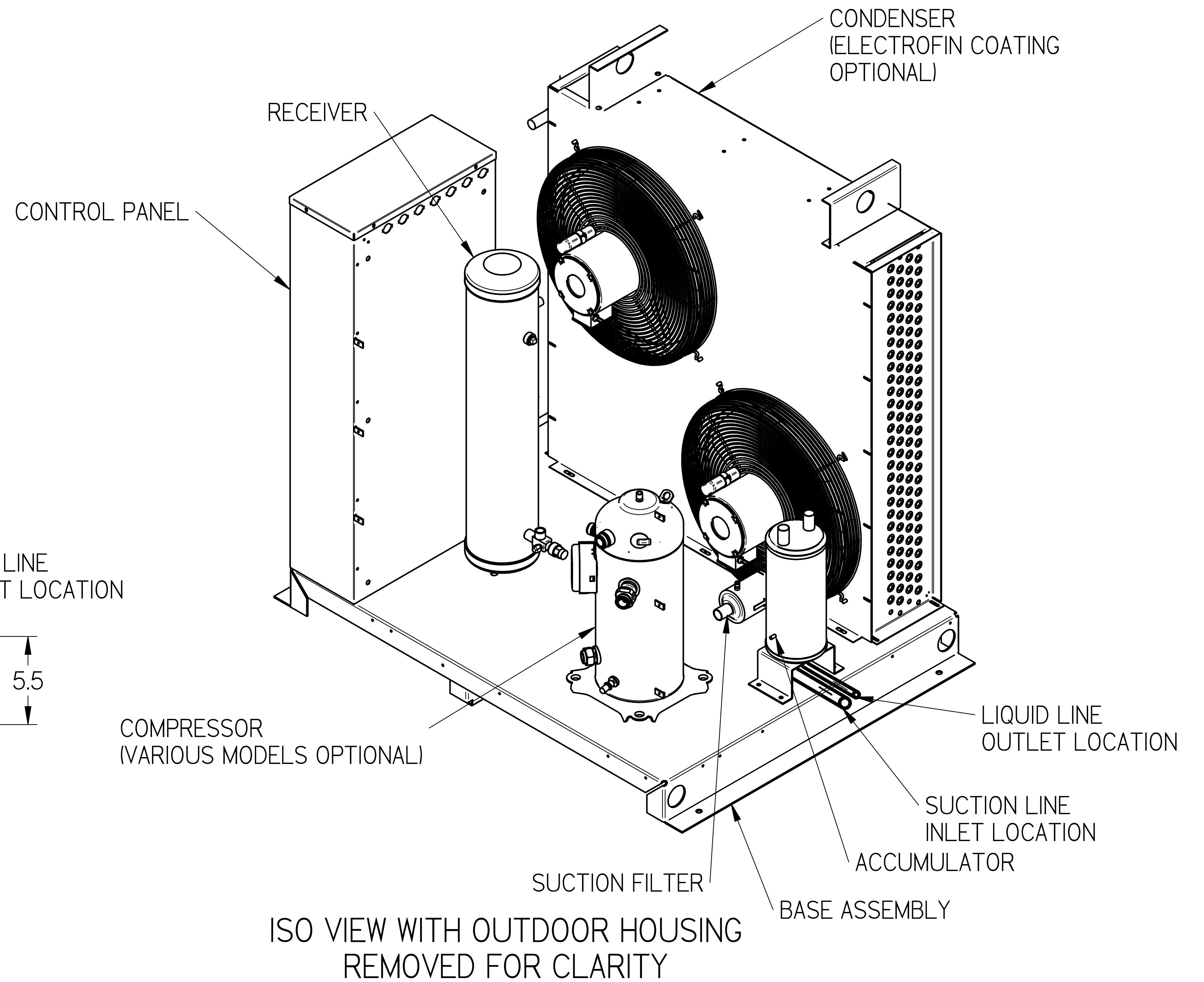

ISO VIEW WITH OUTDOOR HOUSING  
REMOVED FOR CLARITY

NOTES:

1. IT IS THE RESPONSIBILITY OF THE INSTALLING CONTRACTOR TO ENSURE THAT THE FINAL EQUIPMENT INSTALLATION MEETS ALL APPLICABLE CODE REQUIREMENTS.
2. ILLUSTRATION SHOWN IS FOR GENERAL REPRESENTATION ONLY. ACTUAL PRODUCT WILL VARY DEPENDENT UPON APPLICATION.
3. OVERALL DIMENSIONS: 52.0 L X 35.0 W X 42.0 H.

DIMENSIONS ARE IN INCHES.  
DATE DRAWN: 2017/09/14

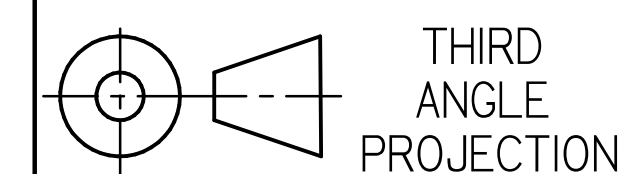

SHEET 2 OF 3

**HUSSMANN**<sup>®</sup>

HIGH EFFICIENCY H  
SERIES MDM OD STD  
BASE SIDE CTL PNL

DOC PD-00000014 REV F

INFORMATION SUBJECT TO CHANGE

SHEET SUBMITTAL SHEET SIZE D

**MINIMUM CLEARANCE REQUIREMENTS:**

ACTUAL CLEARANCE REQUIREMENTS ARE DEPENDENT UPON AUTHORITY HAVING JURISDICTION, AND MAY EXCEED DIMENSIONS SHOWN.

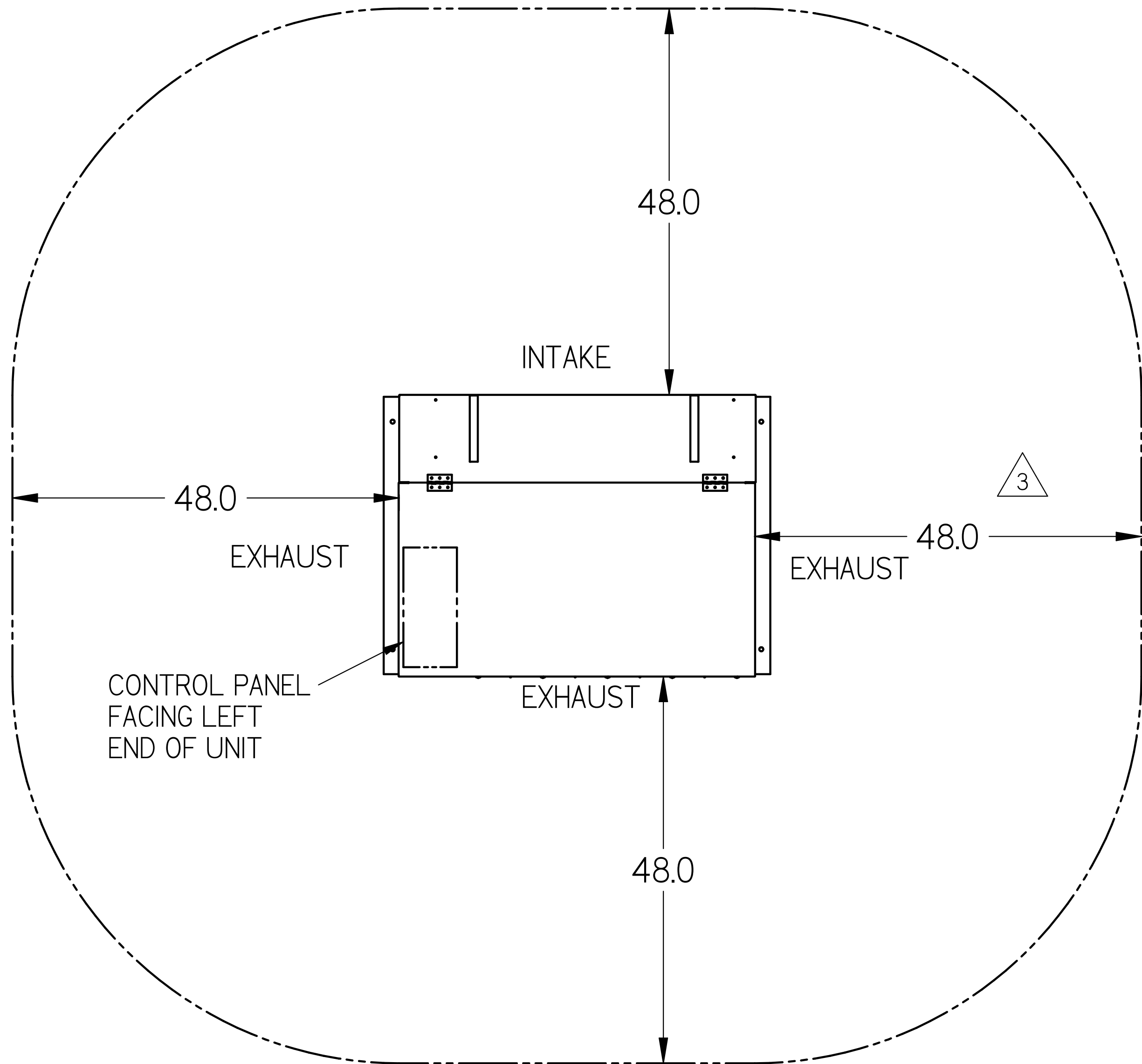

**CLEARANCE ON A SINGLE UNIT APPLICATION**

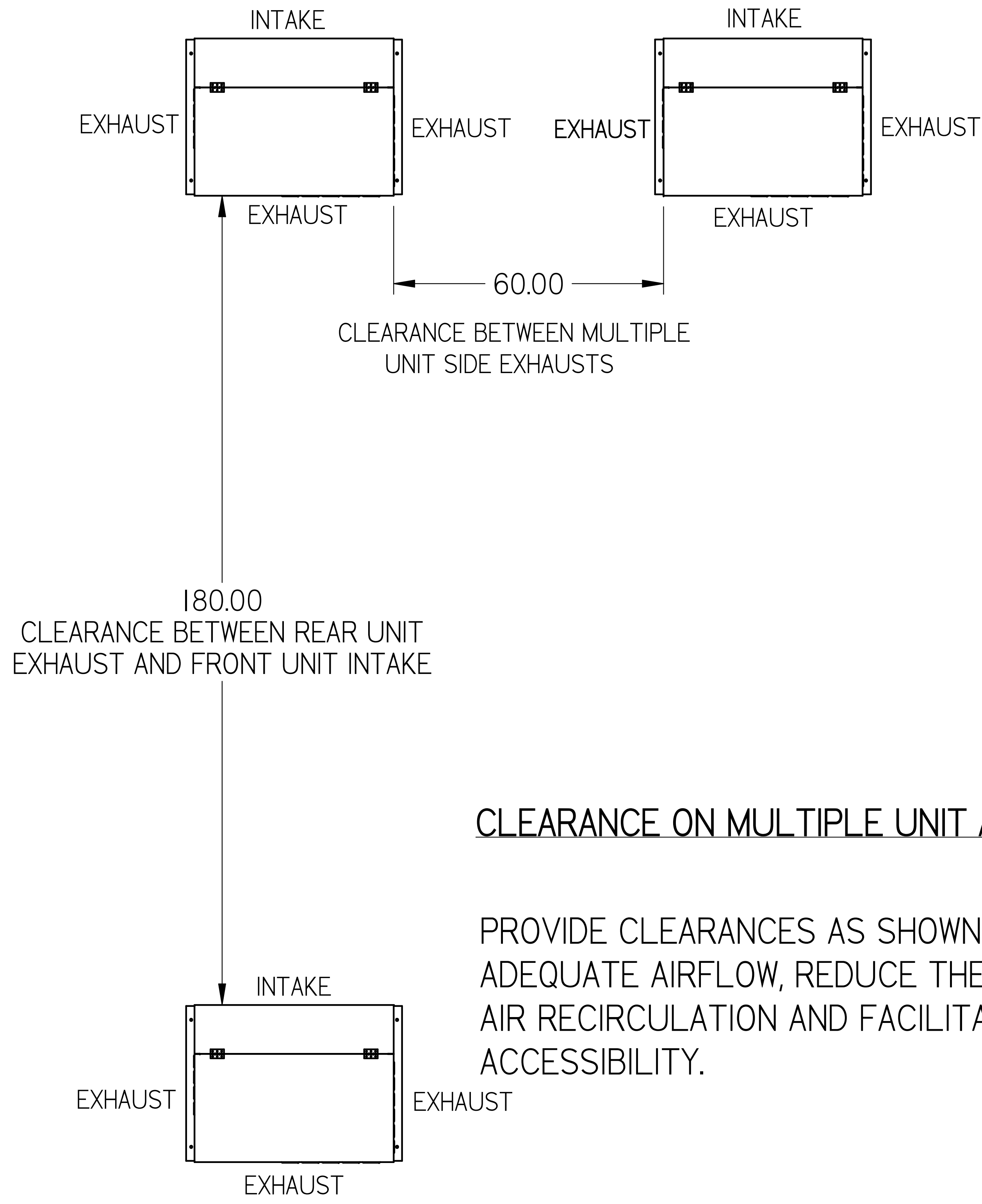

**CLEARANCE ON MULTIPLE UNIT APPLICATION**

PROVIDE CLEARANCES AS SHOWN TO ENSURE ADEQUATE AIRFLOW, REDUCE THE POTENTIAL FOR AIR RECIRCULATION AND FACILITATE SERVICE ACCESSIBILITY.

**NOTES:**

1. IT IS THE RESPONSIBILITY OF THE INSTALLING CONTRACTOR TO ENSURE THAT THE FINAL EQUIPMENT INSTALLATION MEETS ALL APPLICABLE CODE REQUIREMENTS.
2. ILLUSTRATION SHOWN IS FOR GENERAL REPRESENTATION ONLY. ACTUAL PRODUCT WILL VARY DEPENDENT UPON APPLICATION.
3. OVERALL DIMENSIONS: 52.0 L X 35.0 W X 42.0 H.

INFORMATION SUBJECT TO CHANGE

DIMENSIONS ARE IN INCHES. DATE DRAWN: 2017/09/14	<b>HUSSMANN®</b>	
	HIGH EFFICIENCY H SERIES MDM OD STD BASE SIDE CTL PNL	
THIRD ANGLE PROJECTION	SHEET 3 OF 3	DOC PD-000000014 REV F

SWN 1.0 SUBMITTAL SHEET SIZE D