

DOE 2017 Energy Efficiency Compliant Hussmann refrigerated merchandisers configured for sale for use in the United States meet or surpass the requirements of the DOE 2017 energy efficiency standards.

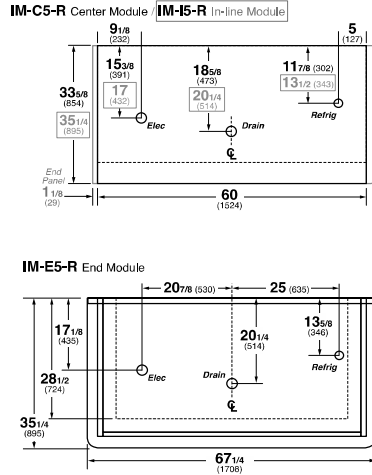

10" canopy depicted (-EC10)

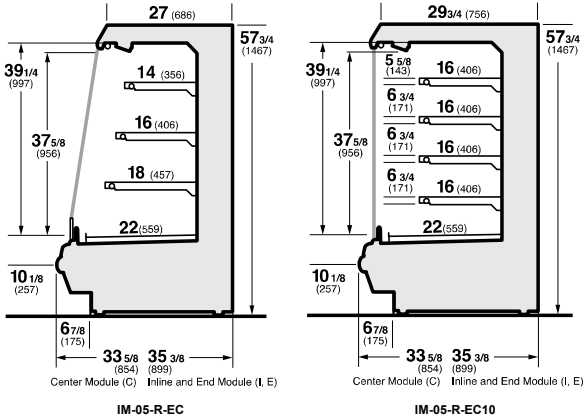

REFRIGERATION DATA:

CASE LENGTHS	CASE USAGE	CAPACITY *** (BTU/HR/FT)		TEMPERATURE (°F)			VELOCITY (FT/MIN)
		RATING CONDITION		EVAPORATOR		DISCHARGE AIR ** (°F)	NSF 7
		NSF 7	AHRI 1200	NSF 7	AHRI 1200	NSF 7	
4', 5', 6', 8', 10', 12'	DELI / DAIRY	990	990	25	25	30~32	225~250
4', 5', 6', 8', 10', 12'	MEAT	1175	990	21	25	28~30	225~250

CASE LENGTHS	EST. REFG. CHR.G. 404A (LBS)	20°F GLYCOL 6° RISE	
		GPM	PSI
4'	1.0	1.6	2.0
5'	1.2	2.0	3.1
6'	1.4	2.4	1.8
8'	2.0	3.1	2.9
10'	2.5	3.8	4.2
12'	2.9	4.5	3.9

**FRONT DISCHARGE AIR MEASURED INSIDE AIR CURTAIN HONEYCOMB

***REFRIGERATION NOTES:

- 1) BTU'S INCLUDE CANOPY LIGHTS. ADD 10 BTUS/SHELF/FT FOR EACH SHELF (LIGHT)
- 2) MEAT CASE SPECS ARE FOR PACKAGED MEAT.
- 3) AHRI 1200 RATING POINT FOR ENERGY CONSUMPTION COMPARISON ONLY.
- 4) USE DEW POINT FOR HIGH GLIDE REFRIGERANTS. CARE SHOULD BE TAKEN TO USE THE DEW POINT IN P/T TABLES FOR MEASURING AND ADJUSTING SUPERHEAT. ADJUST EVAPORATOR PRESSURE AS NEEDED TO MAINTAIN THE DISCHARGE AIR TEMPERATURE SHOWN.
- 5) RATING CONDITION IS NSF TYPE I, 75°F/55% RH

REFRIGERATION DATA CONTINUED:

ELEC. THERMOSTAT / AIR SENSOR SETTINGS			DEFROST TYPE	TIME (MIN)	DEFROST FREQUENCY (#/DAY)	TERM. TEMP (°F) COIL ONLY	DRIP TIME	DEFROST WATER (LBS/DAY/FT)
USAGE	CUT IN (°F)	CUT OUT (°F)						
DELI / DAIRY	33	30	OFF TIME	20	6	48	N/A	6.5
MEAT	31	28	OFF TIME	20	6	48	N/A	9

END PANEL WIDTH KEY		
# OF END PNLS	END PNL	TOTAL ADDED LENGTH (IN.)
1	1.125	1.125
2	1.125	2.25

ELECTRICAL DATA:

STANDARD FANS, HEATERS, LED LIGHTS (115 VOLT)

CASE LENGTH	EVAPORATOR FANS					CANOPY LIGHTS LED		LED SHELF LIGHTS		MAX. LED LOAD (W/ ALL OPTIONS)		ANTI-SWEAT HEATERS (ON FAN CIRCUIT)		CONVENIENCE OUTLETS (OPTIONAL)		
	# OF EVAP FANS	BLADE DIA. (IN.)	BLADE PITCH (°)	AMPS	WATTS	AMPS	WATTS	AMPS	WATTS	AMPS	WATTS	AMPS	WATTS	# OUTLETS	VOLTS	AMPS
4'	1	8	25	0.3	8	0.23	27	0.27	31	0.50	58	N/A	N/A	N/A	N/A	N/A
5'	1	8	30	0.3	8	0.30	34	0.34	39	0.63	73	N/A	N/A	N/A	N/A	N/A
6'	2	8	25	0.6	16	0.34	39	0.40	46	0.74	85	N/A	N/A	N/A	N/A	N/A
8'	2	8	25	0.6	16	0.47	54	0.54	62	1.01	116	N/A	N/A	N/A	N/A	N/A
10'	2	8	30	0.6	16	0.59	68	0.68	78	1.27	146	N/A	N/A	N/A	N/A	N/A
12'	3	8	25	0.9	24	0.70	81	0.81	93	1.51	173	N/A	N/A	N/A	N/A	N/A

OPTIONAL HIGH OUTPUT LED LIGHTS (115 VOLT)

CASE LENGTH	CANOPY LIGHTS H.O. LED		SHELF LIGHTS H.O. LED		MAX. H.O. LED LOAD	
	AMPS	WATTS	AMPS	WATTS	AMPS	WATTS
4'	0.28	32	0.40	46	0.67	78
5'	N/A	N/A	N/A	N/A	N/A	N/A
6'	0.41	47	0.68	78	1.09	125
8'	0.56	64	0.79	91	1.35	155
10'	N/A	N/A	N/A	N/A	N/A	N/A
12'	0.83	96	1.19	137	2.02	233