



Intertek



Intertek

MEDIUM TEMP SELF SERVICE MULTI-DECK SELF-CONTAINED
HUSSMANN Isla - IM-05-(E or C)(X)-S CASE MODULES (ISLA) (CHINO)

REVISION DATE

05/21/21



Hussmann refrigerated merchandisers configured for sale for use in the United States meet or surpass the requirements of the DOE 2017 energy efficiency standards.

IM-05-Ix-S End or Combo Center Case

IM-05/04-S Refrigerated Multi-Deck Self-Service Self-Contained

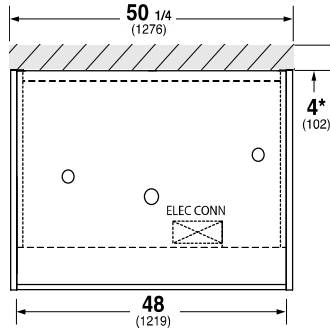

*MIN required air space for condenser air discharge.

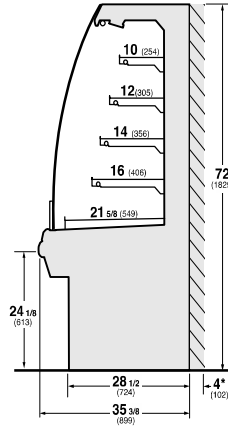

*MIN required air space for condenser air discharge.



REFRIGERATION DATA:

CASE LENGTHS	CASE USAGE	CONVENTIONAL CAPACITY ** (BTU/HR/FT)	DISCHARGE AIR * (°F)	VELOCITY (FT/MIN)
3',4',5',6',8'	DELI / DAIRY	1200	30~32	250~270
3',4',5',6',8'	MEAT	1380	28~30	250~270

*FRONT DISCHARGE AIR MEASURED INSIDE AIR CURTAIN HONEYCOMB

**REFRIGERATION NOTES:

- 1) CAPACITY FOR REFERENCE ONLY
- 2) USE DEW POINT FOR HIGH GLIDE REFRIGERANTS. CARE SHOULD BE TAKEN TO USE THE DEW POINT IN P/T TABLES FOR MEASURING AND ADJUSTING SUPERHEAT.
- 3) NSF RATING CONDITION IS NSF TYPE II, 80°F / 55% RH

REFRIGERATION DATA CONTINUED:

CONTROLLER / AIR SENSOR SETTINGS			DEFROST TYPE	FAIL SAFE TIME (MIN)	DEFROST FREQUENCY (#/DAY)	TERM. TEMP (°F) AIR	DRIP TIME (MIN)	DEFROST WATER (LBS/DAY/FT)
USAGE	SET POINT (°F)	DIFFERENTIAL (°F)						
DELI	26	12	OFF TIME	30	4	52	NA	5.9
MEAT	22	12						

END PANEL WIDTH KEY		
# OF END PNLS	END PNL WIDTH (IN.)	TOTAL ADDED LENGTH (IN.)
1	1.125	1.125
2	1.125	2.25

4) DEFROST IS BASED ON TERMINATION TEMP, WHICH UNDER NORMAL CIRCUMSTANCES, IS SHORTER THAN FAILSAFE TIME.

ELECTRICAL DATA:

STANDARD FANS, HEATERS, LED LIGHTS (115 VOLT)

CASE LENGTH	EVAPORATOR FANS					LED CANOPY LIGHTS		LED SHELF LIGHTS		MAX. LED LOAD (W/ ALL OPTIONS)		ANTI-SWEAT HEATERS		CONVENIENCE OUTLETS (OPTIONAL)		
	# OF EVAP FANS	BLADE DIA. (IN.)	BLADE PITCH (°)	AMPS	WATTS	AMPS	WATTS	AMPS	WATTS	AMPS	WATTS	AMPS	WATTS	#	VOLTS	AMPS
														OUTLETS		
3'	1	8	25	0.3	8	0.17	19	0.20	23	0.37	42	N/A	N/A	N/A	N/A	N/A
4'	1	8	25	0.3	8	0.23	27	0.27	31	0.50	58	N/A	N/A	N/A	N/A	N/A
5'	1	8	30	0.3	8	0.30	34	0.34	39	0.63	73	N/A	N/A	N/A	N/A	N/A
6'	2	8	25	0.6	16	0.34	39	0.40	46	0.74	85	N/A	N/A	N/A	N/A	N/A
8'	2	8	25	0.6	16	0.47	54	0.54	62	1.01	116	N/A	N/A	N/A	N/A	N/A

CONDENSING UNIT AND EVAPORATIVE PANS (115 & 208V)

CASE LENGTH	CONDENSING UNIT					EVAPORATIVE PAN			EST. REFG. CHR.G. (LBS) / CU	NEMA PLUG
	NOM. HP	REFRIG.	Hz/Ph	Volts	RLA	VOLTS	AMPS	WATTS		
3'	3/4	404a	60/1	208	6.8	240	4.8	1000	4.6	14-20P
4'	1		60/1	208	9.0	240	6.3	1500	6.0	14-20P
5'	1-1/4		60/1	208	9.3	240	6.3	1500	6.6	14-30P
6'	1-3/4		60/1	208	12.6	240	6.3	1500	10.3	14-30P
8'	2 X 1		60/1	208	18.6	240	8.3	2000	6.0	CS-6365-C
3'	3/4	448a	60/1	208	6.8	240	5.0	1200	4.6	N/A
4'	1		60/1	208	9.3	240	6.3	1500	6.0	N/A
5'	1-1/4		60/1	208	9.3	240	6.3	1500	6.6	14-30P
6'	1-3/4		60/1	208	12.6	240	6.3	1500	10.3	14-30P
8'	2 X 1		60/1	208	18.6	240	8.3	2000	6.0	CS-6365-C

OPTIONAL HIGH OUTPUT LED LIGHTS (115 VOLT)

CASE LENGTH	CANOPY LIGHTS H.O. LED		SHELF LIGHTS H.O. LED		MAX. H.O. LED LOAD	
	AMPS	WATTS	AMPS	WATTS	AMPS	WATTS
3'	0.21	24	0.34	39	0.54	63
4'	0.28	32	0.40	46	0.67	78
5'	N/A	N/A	N/A	N/A	N/A	N/A
6'	0.41	47	0.68	78	1.09	125
8'	0.56	64	0.79	91	1.35	155