

# HUSSMANN® IMPACT

## MWGE Fan Blade and Honeycomb Retrofit Kit Instruction (DK57 or DK58)

Wide Island Meat, Deli and Cheese Merchandisers

### PARTS LIST FOR DK57

Item Nos.	Part Nos.	Quantity	Description
1.	124150	1	Fan Blade
2.	412617	1	Clear Honeycomb

### PARTS LIST FOR DK58

Item Nos.	Part Nos.	Quantity	Description
1.	124150	1	Fan Blade
2.	412618	1	Black Honeycomb

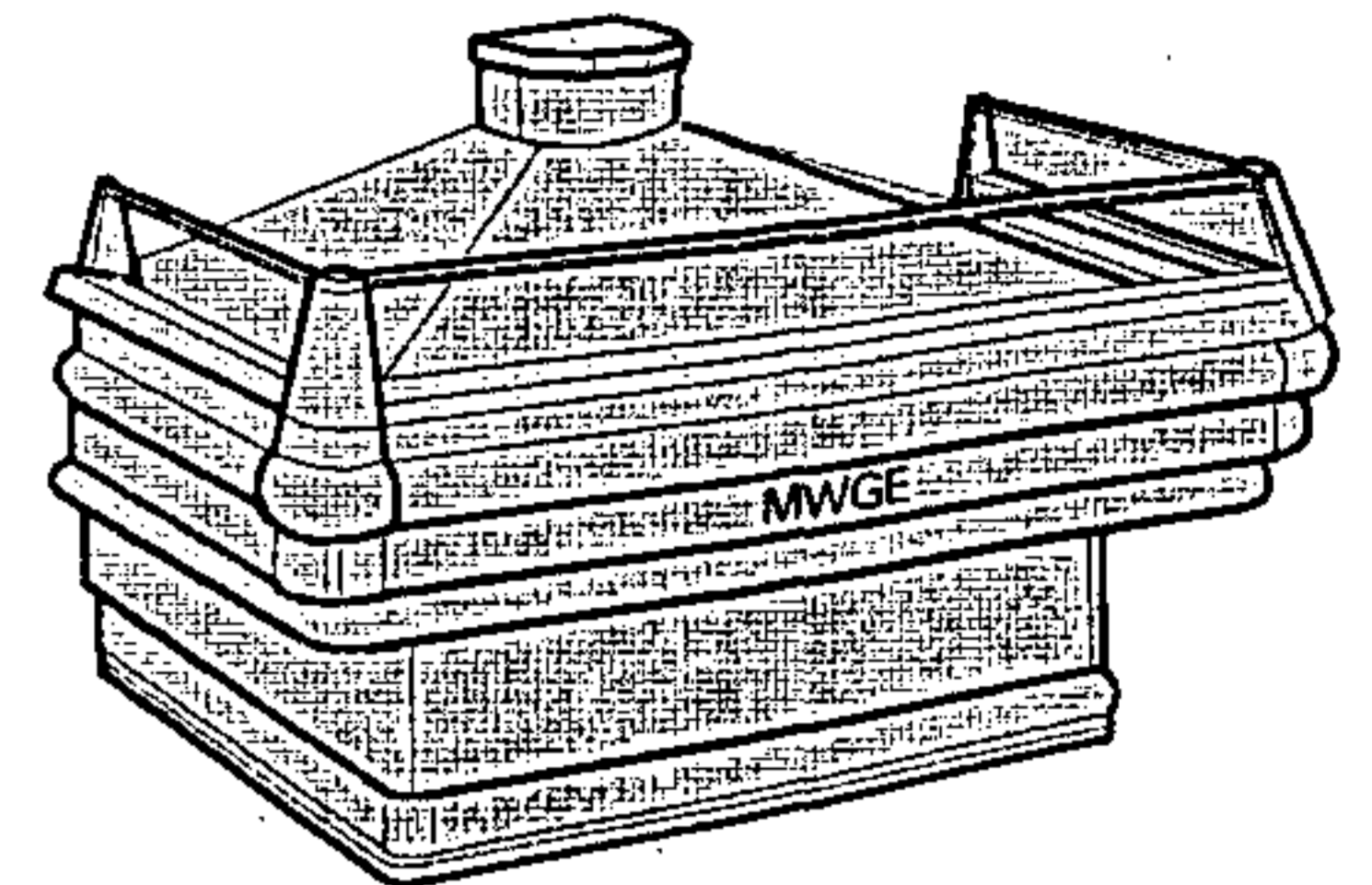

RETROFIT KIT

**NOTE:** Carefully unpack and inspect the MWGE Fan and Honeycomb Retrofit Kit, making sure there is no breakage or damage.

**⚠ WARNING**

Always disconnect the electrical power at the main disconnect when servicing or replacing any electrical component. This includes, but is not limited to, such items as fans, heaters, thermostats and lights.

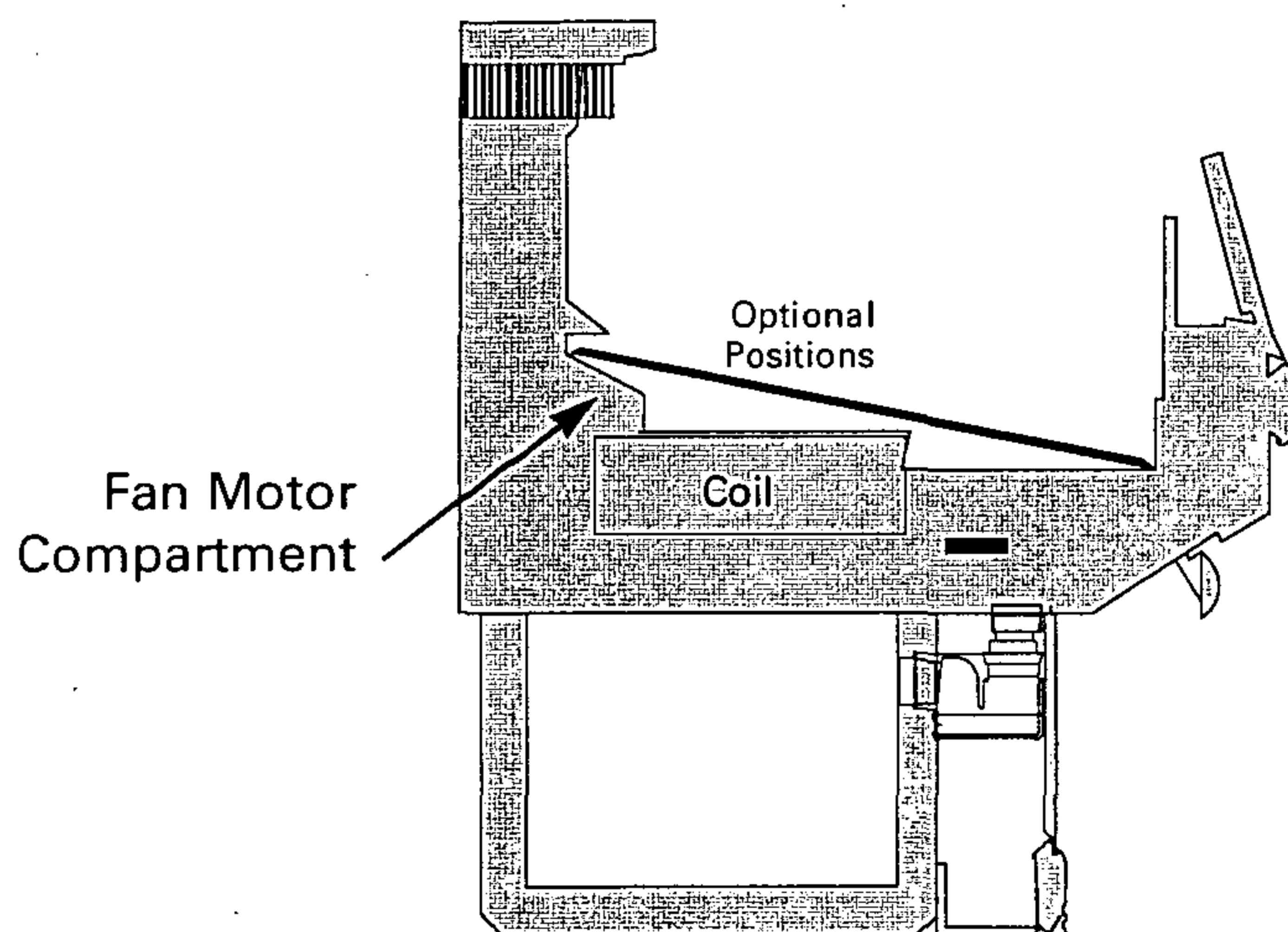
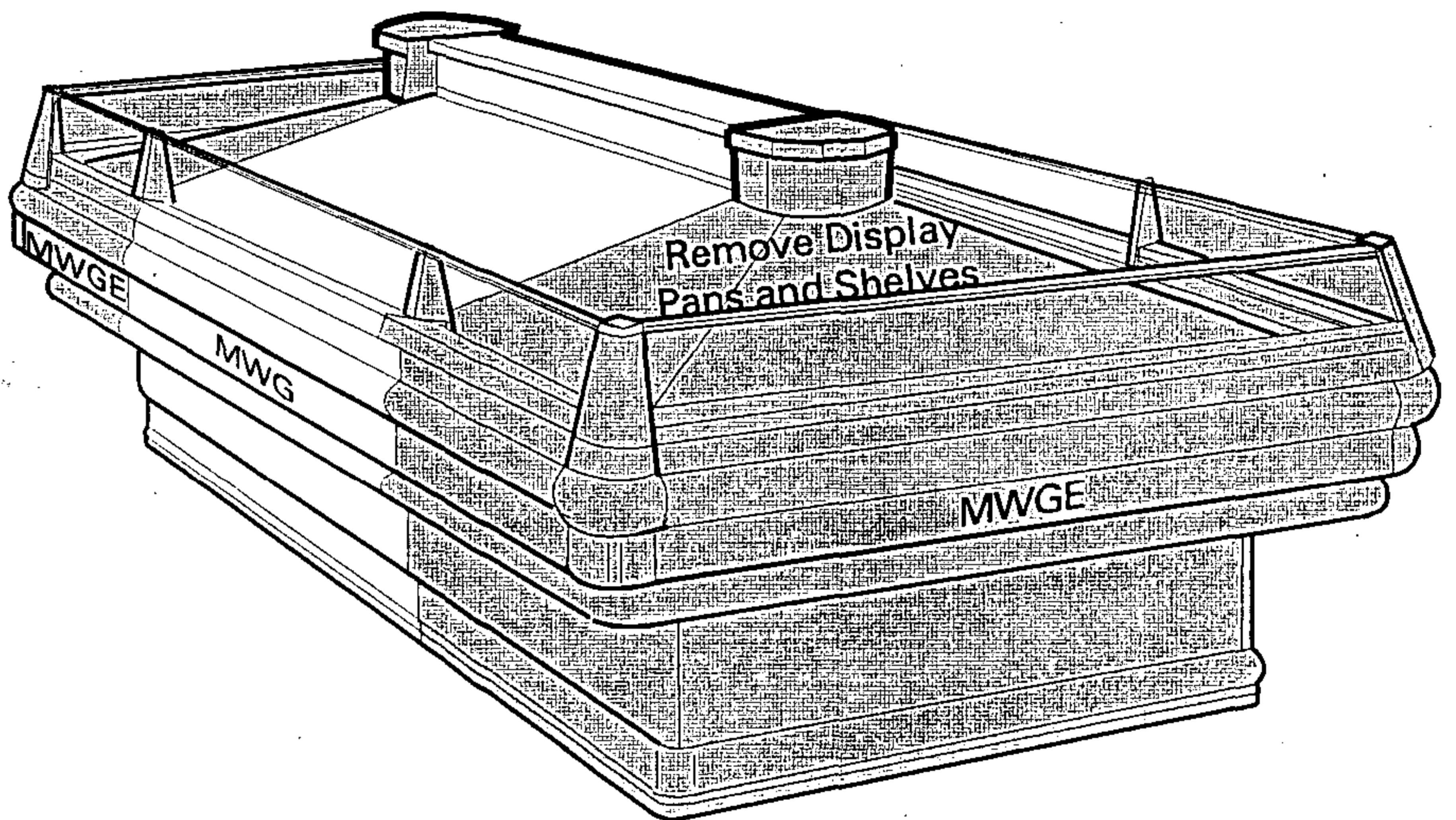

SIDE VIEW

### STEPS

- 1 Remove **product, display shelves** and **display pans** to gain access to the fan motor compartment.

**Fig. 1.** Removing Shelves and Display Pans

August, 1998  
P/N 413747



- 2** Remove the (8) screws from the **Front Plenum Cover** and save for reinstallation later, as shown in Figure 2.

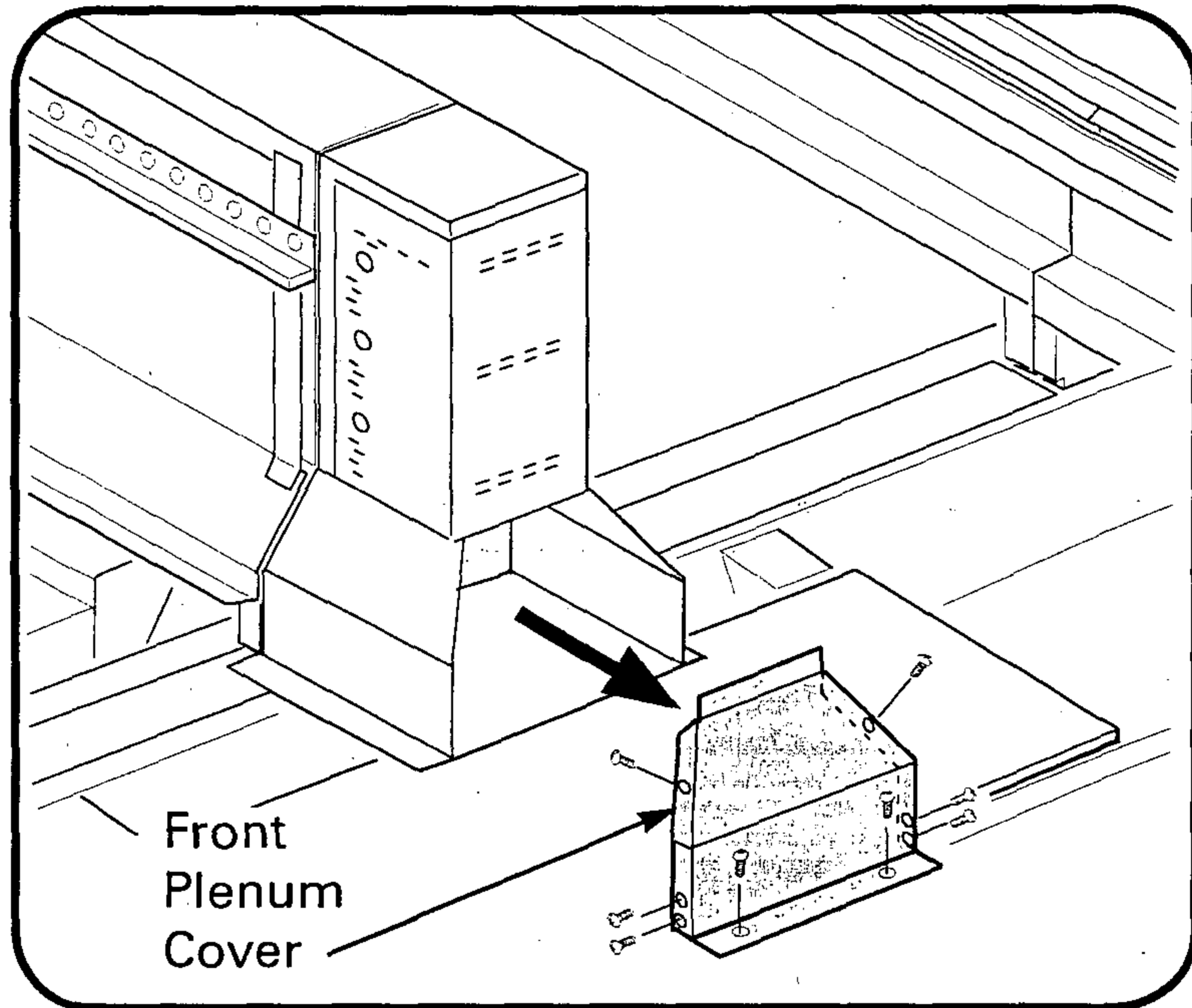

**Fig. 2.** Removing Front Plenum Motor Cover

- 3** Remove the **Fan Motor Assembly** from the center flue by unscrewing the (4) screws that attach the assembly to the flue.

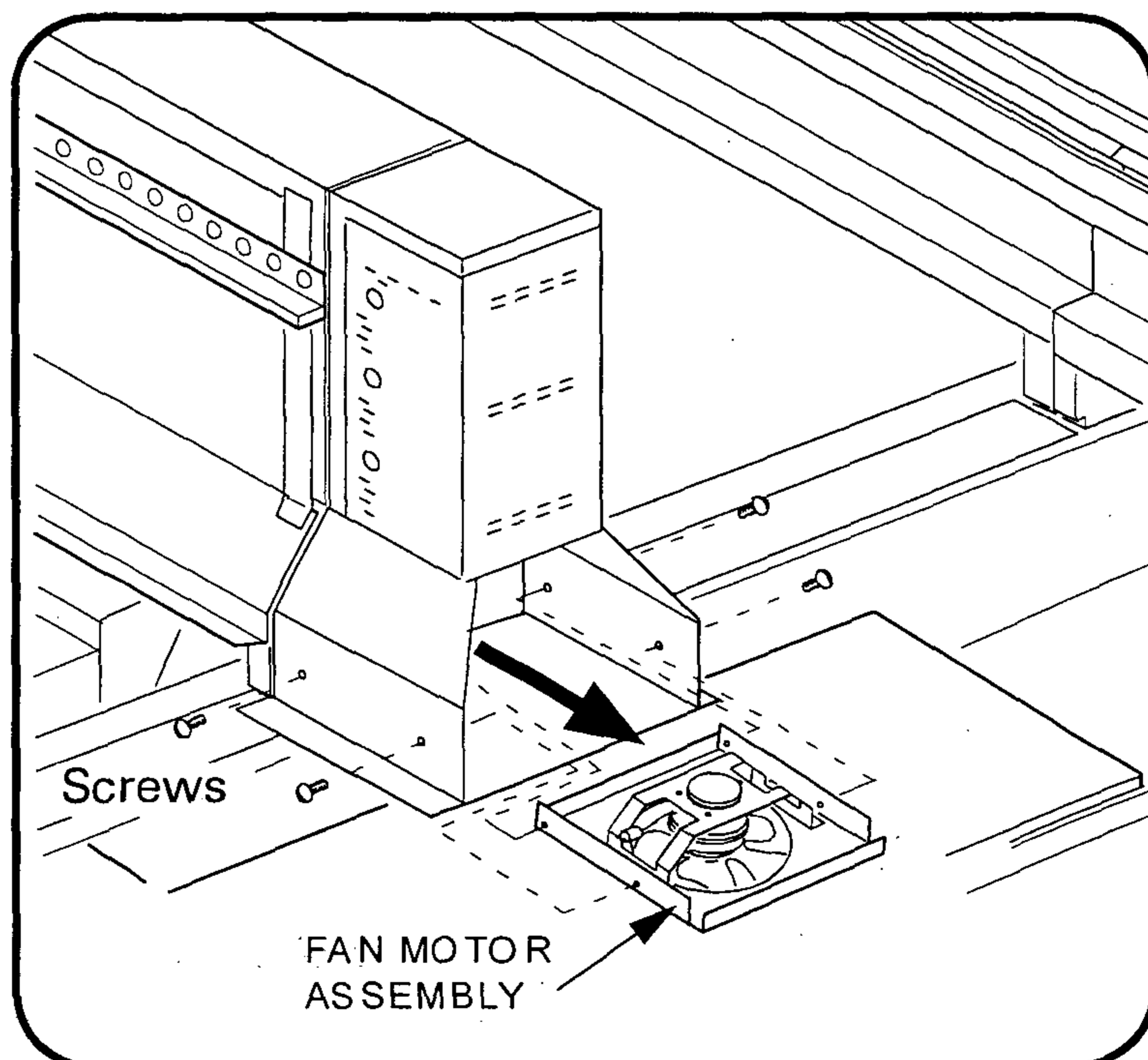

**Fig. 3.** Removing Fan Motor Assembly



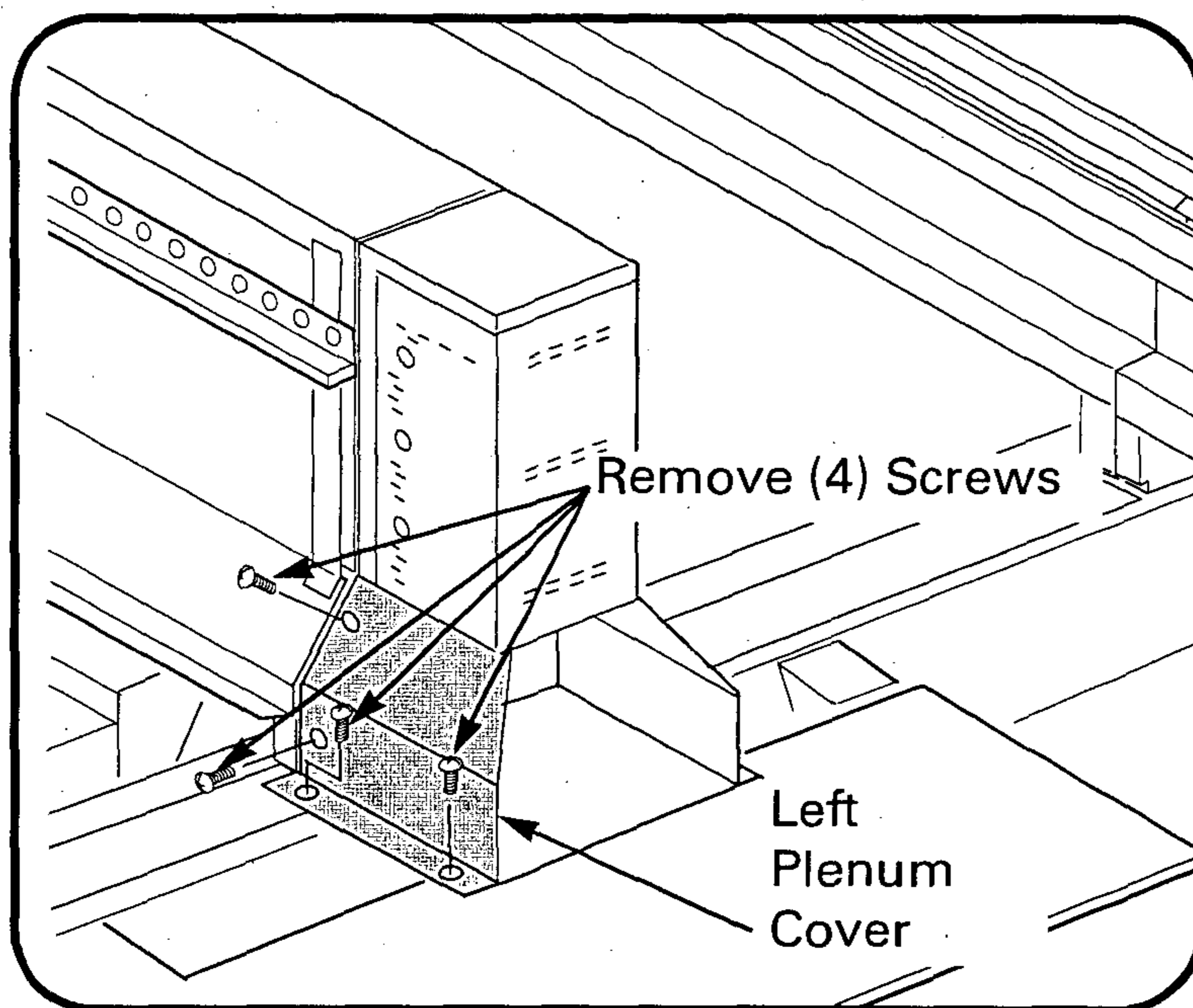

Fig. 4. Removing Front Plenum Motor Cover

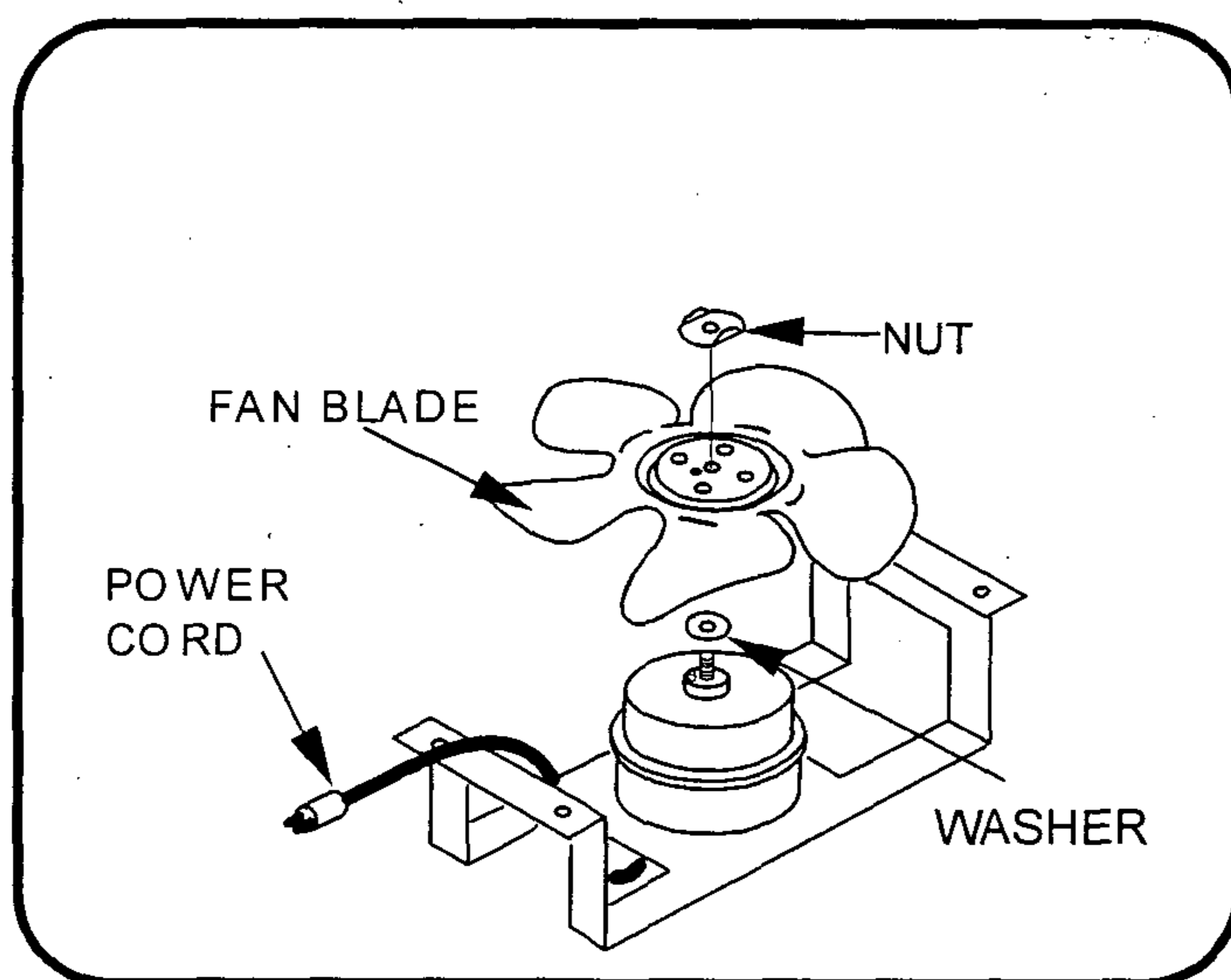

Fig. 5. Installing New Fan Blade

**4** Remove the (4) Screws from the *Left Plenum Cover* and save for reinstallation later, as shown in Figure 4.

**5** Unplug the electrical connector to the motor.

**6** Remove Nut and Fan Blade from the motor shaft.

**7** Install the *New Aluminum Fan Blade* (5 paddle, 8" in diameter with a 30° pitch). Be sure the *Part Number 124150*, is facing towards the fan motor.

**8** Align the hole with the alignment pin. Reinstall nut onto motor shaft and tighten.



**9** Plug the motor power cord back into the electrical connector.

**10** Reverse Steps 1, 2, 3 and 4.

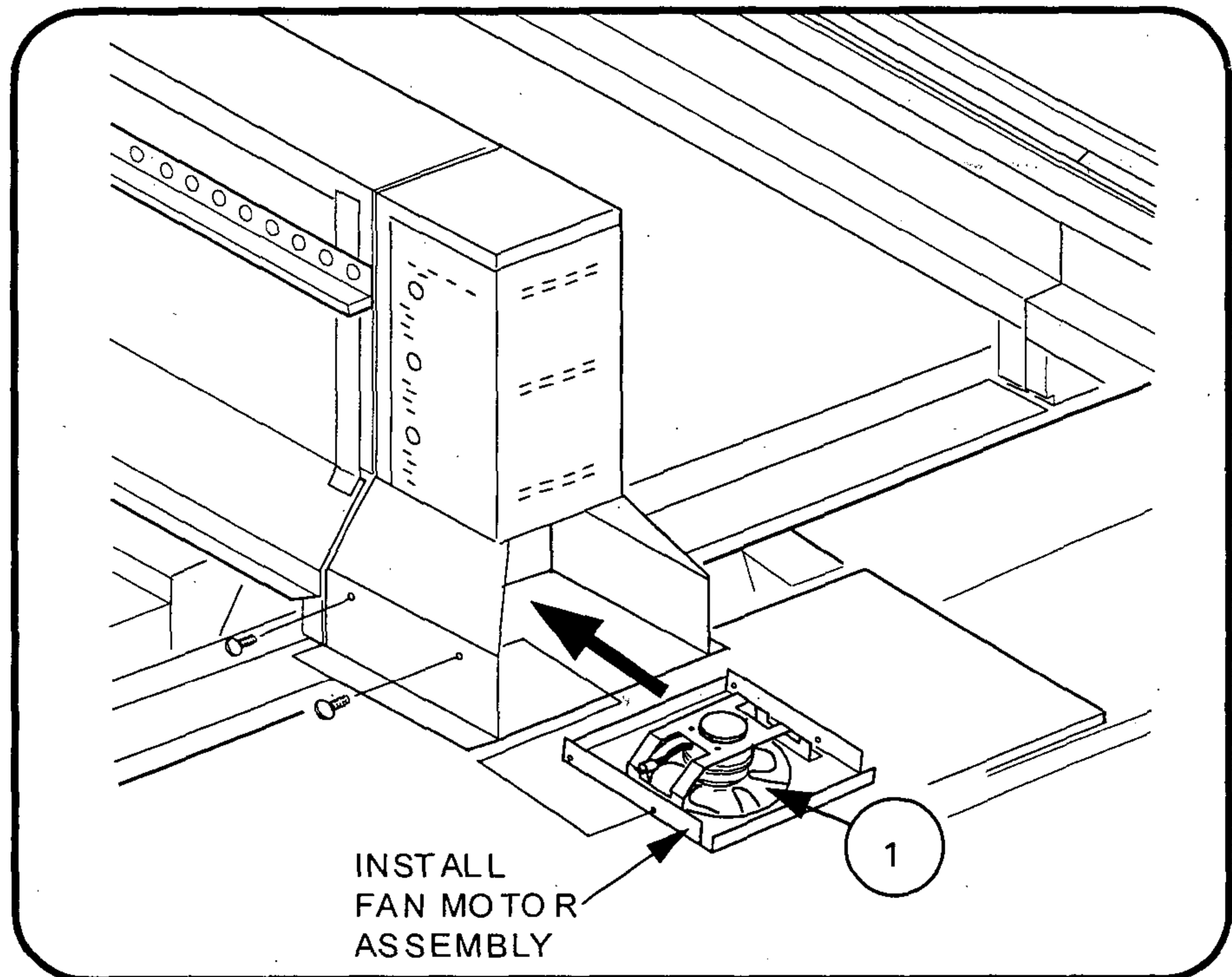
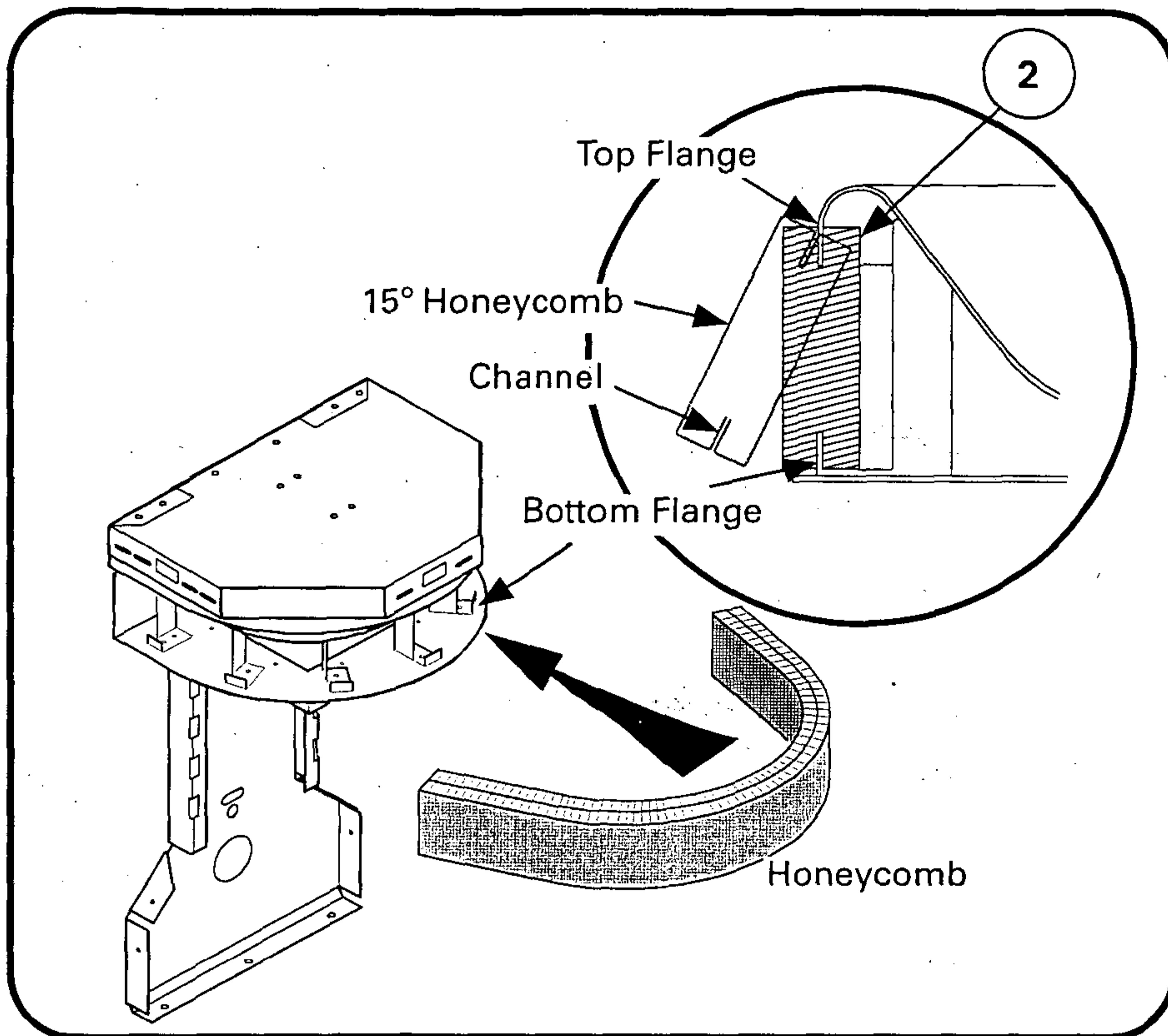

**Fig. 6.** Re-installing Fan Motor Assembly

**! CAUTION**

Make sure the fan blade does not come into contact with the refrigeration coil. If fan blade does come into contact with the refrigeration coil, refer to Steps 13— to 18.





**Fig. 7** Installing New Honeycomb

**11** Remove standard 1/4" honeycomb from the end case by compressing and pulling it out of the top and bottom flanges.

**12** Insert *New 1/8", 15° angled Honeycomb* into place by pressing the honeycomb until the honeycomb's channel is properly seated in the top and bottom flanges. (See Figure 7).

**CAUTION**

Make sure honeycomb cells are angled downward. Failure to do so could result in poor or inadequate refrigeration performance.

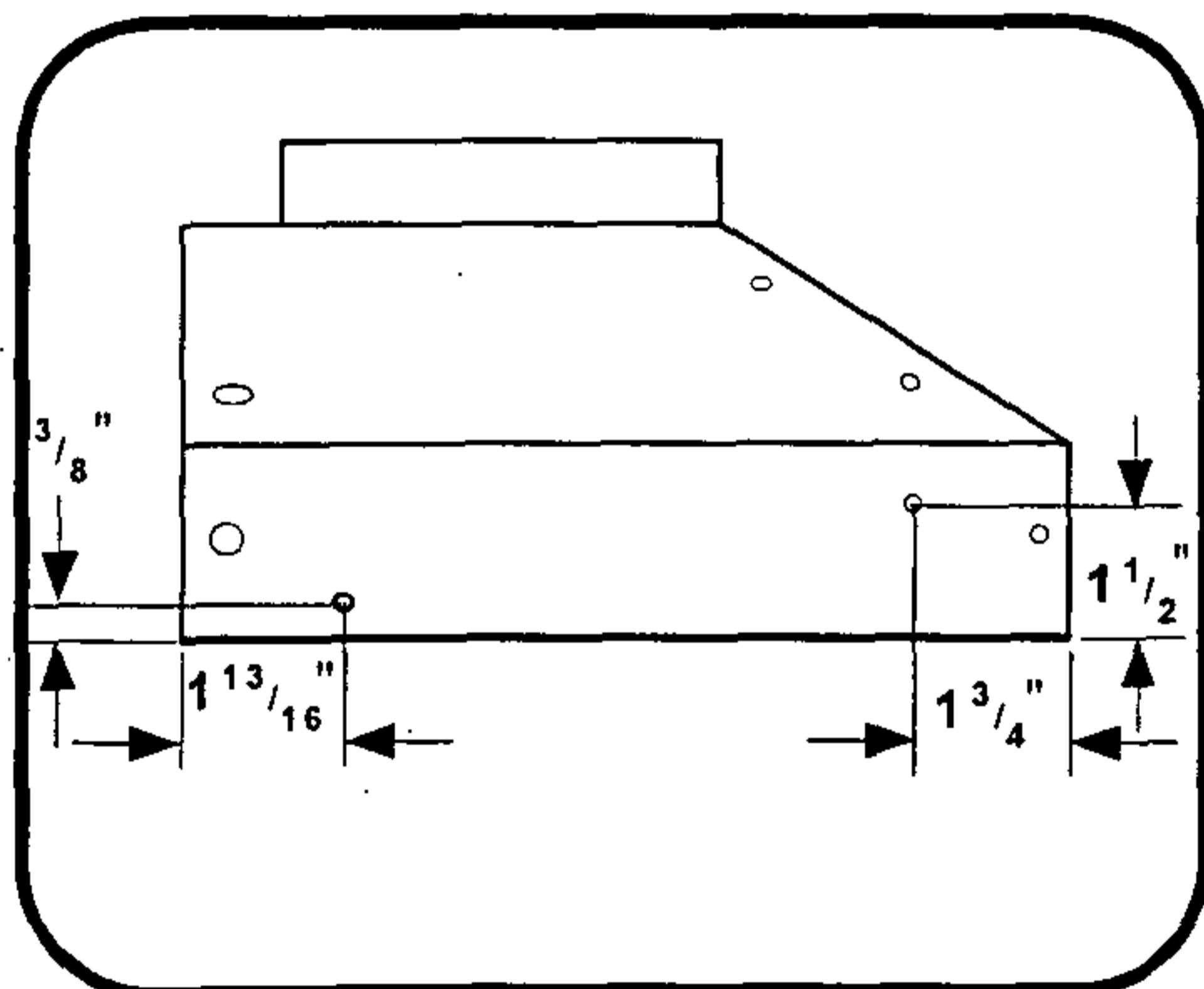

**Fig. 8** Left Plenum Cover Hole Location

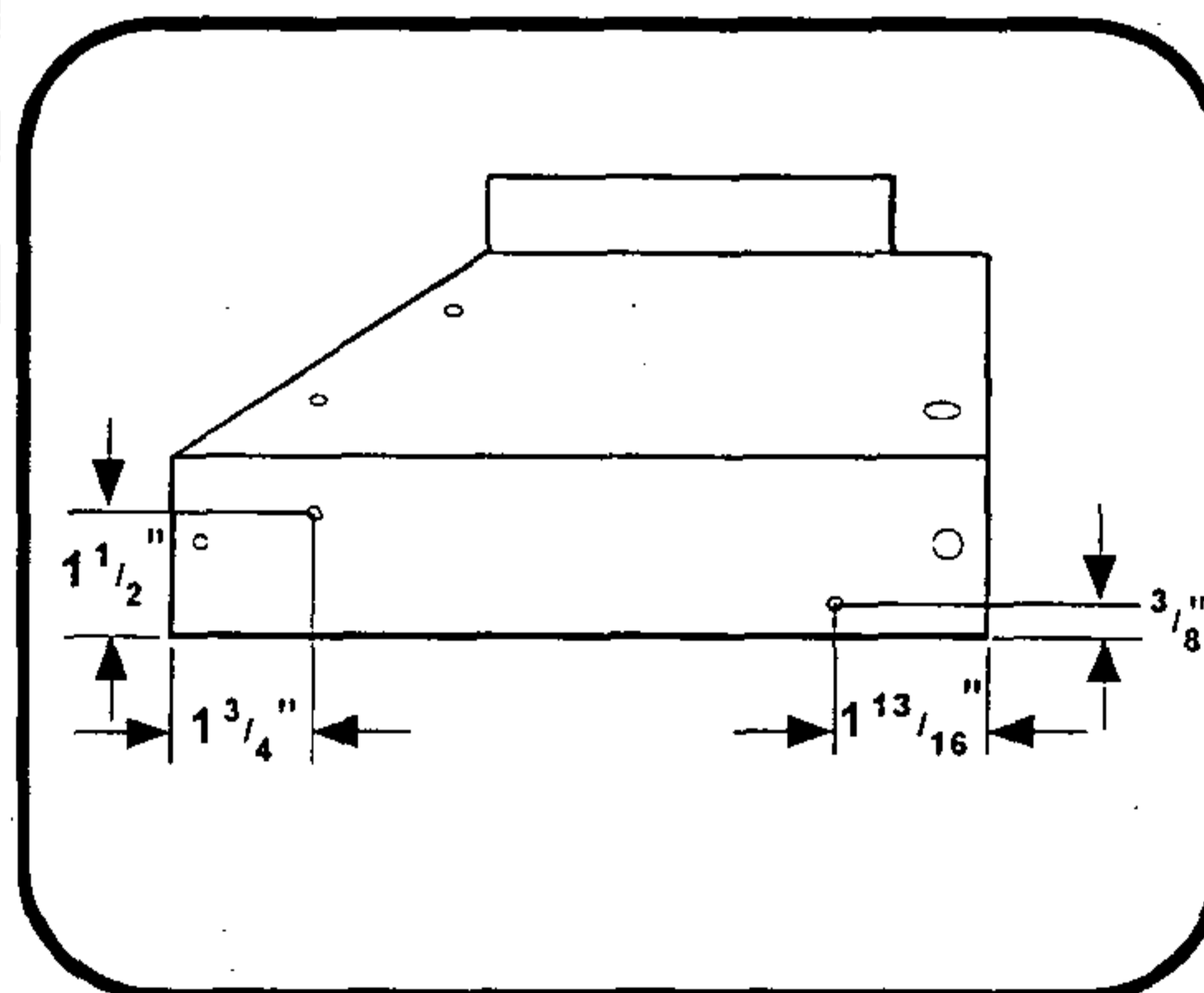

**Fig. 9** Right Plenum Cover Hole Location

**13** Remove Right Plenum Cover (follow same sequence as Step 4).

**14** Drill (2) — 1/4" holes in the *Left Plenum Cover* as shown in Figure 8.

**15** Drill (2) — 1/4" holes in the *Right Plenum Cover* as shown in Figure 9.



**16** Remove (4) screws from the plenum and save for reinstallation later, refer to Figure 10.

**17** Invert plenum and reattach Fan Motor Assembly to Plenum using Screws saved in Step 10.

**18** Reverse Steps 1, 2, 3 and 4, make sure the fan motor assembly is reinstalled using the (4) new holes that were drilled in Steps 14 and 15.

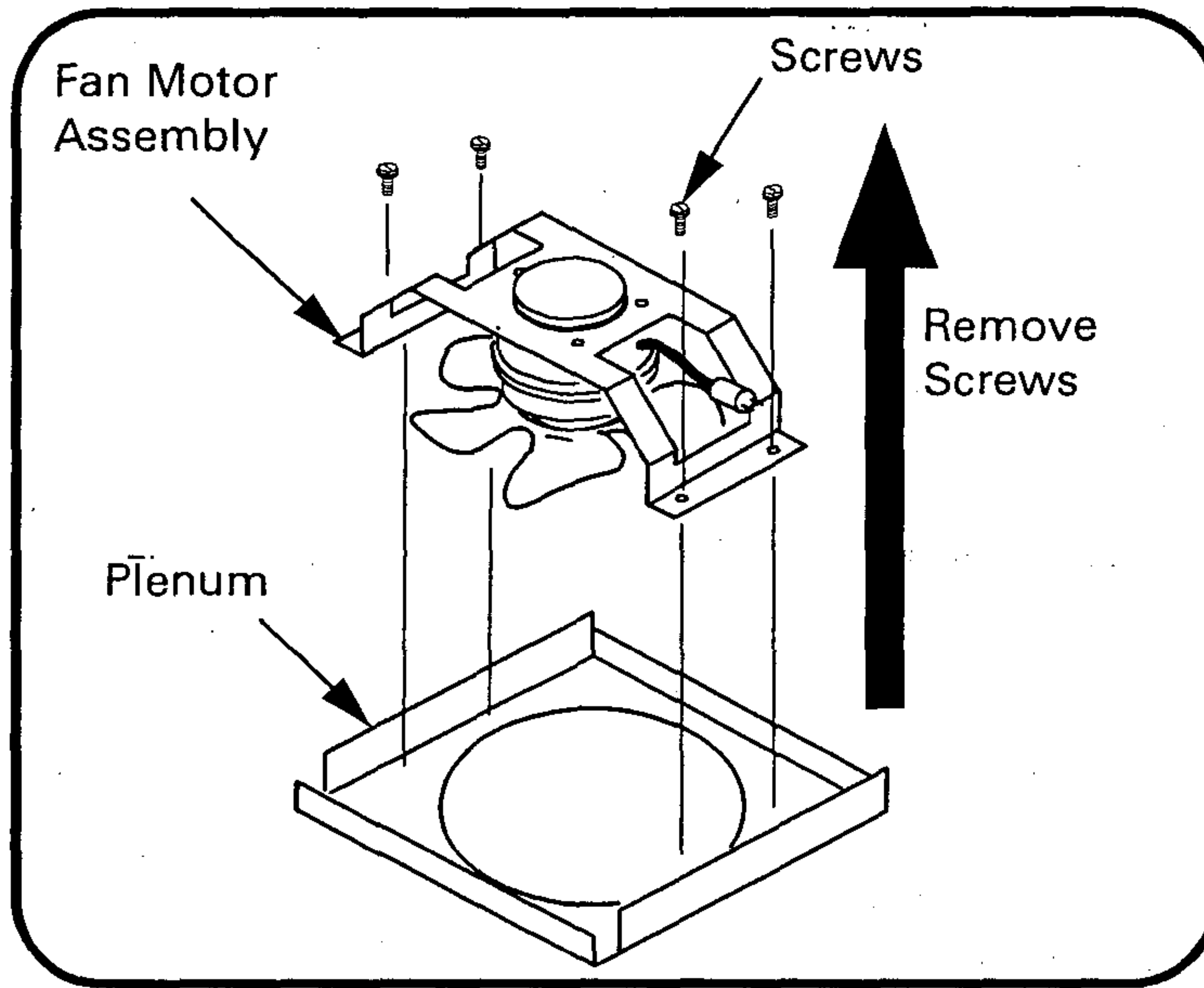

**Fig. 10** Removing Screws from Fan Plenum

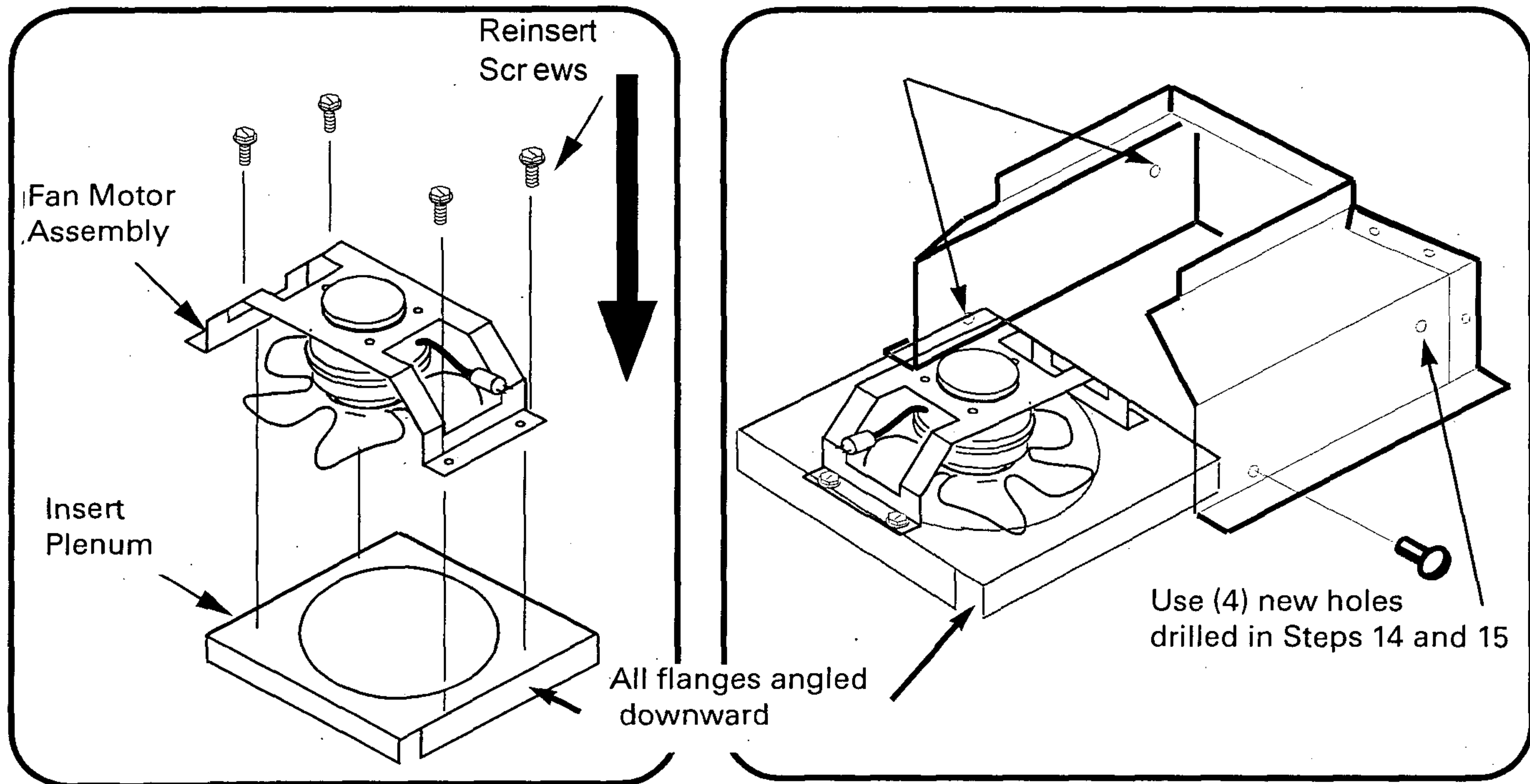

**Fig. 11** Installing Fan Motor Assembly and Plenum to Plenum Cover