

Single Level Wall Display

Vision NC1
Ice Cream

Refrigeration Data

Discharge Air °F	-20
Evaporator °F	-30
Unit Sizing °F	-33
<i>BTU/HR/FOOT</i>	
Parallel	370
Satellite	385
Conventional	425

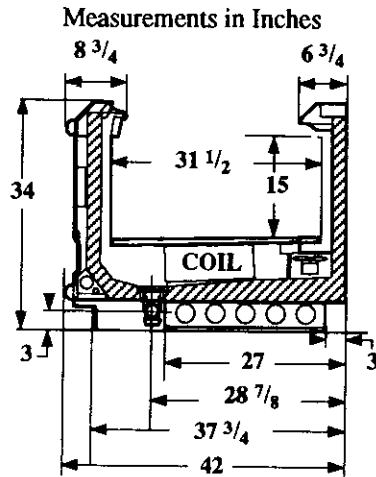

Defrost Data

Frequency Hrs	24
<i>ELECTRIC</i>	
Temp Term °F	52
Failsafe Min	60
<i>REVERSE AIR</i>	
Temp Term °F	48
Failsafe Min	90
<i>GAS</i>	
Duration Min	24
<i>OFFTIME</i>	
Duration Min	NA

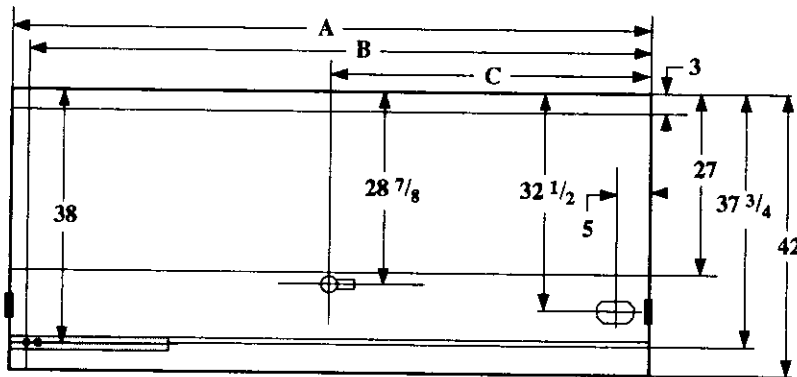

	Electrical Service	Dimension	8' Case	12' Case
	Waste Outlet	A	96 1/4	144 3/8
	Refrigeration Outlet	B	93 5/8	141 3/4
	Passageway Port	C	48 1/8	72 1/4

Conventional Controls

Low Pressure Backup Control	
CI/CO (PSIG)	
R-22 7/0	R-502 7/0
Indoor Condenser only, Pressure	
Defrost Termination (PSIG)	
R-22 NA	R-502 NA

Physical Data

Merchandiser	
Drip Pipe (ins)	1 1/2
Liquid Line (ins)	3/8
Suction Line (ins)	7/8

Evaporator Estimated Charge		
Length	R-22	R-502
	(lbs)	(lbs)
8	17	13
12	21	19

Length Added to Lineup by	
Ends and Partitions	
Each End (ins)	1 1/2
Each Insulated	
Parttion (ins)	1 1/2

Vision NC1 Ice Cream

Electrical Data
Merchandiser

Number of Fans - Evaporator

8Ft	12Ft
2	3

Merchandiser	Amperes		Watts	
	8Ft	12Ft	8Ft	12Ft
Fans				
Standard	1.20	1.80	80	120
Energy Efficient	0.40	0.60	40	60
Reverse Air	0.62	0.93	60	90
Constant on Anti-sweat Heaters	1.00	1.50	120	180
Cycling Anti-sweat Heaters	NA			
Min. Circuit Ampacity				
With Standard Fans	2.40	3.50		
With Energy Efficient Fans	1.60	2.30		
With Reverse Air Fans	1.82	2.63		
Max. Over Current Protection	20	20		
Supplemental Gas Heaters	0.2	0.2	25	25
208V 1Φ Electric Defrost	8.2	12.1	1706	2517
120V 1Φ Supplemental Rev. Air	6.8	9.9	816	1188

Standard Lighting

None

Revised 12-15-93