

Multideck, 6 Display Levels, 19 1/2 inch Front
Solid Back only

Vision ND6L UNLIT Dairy

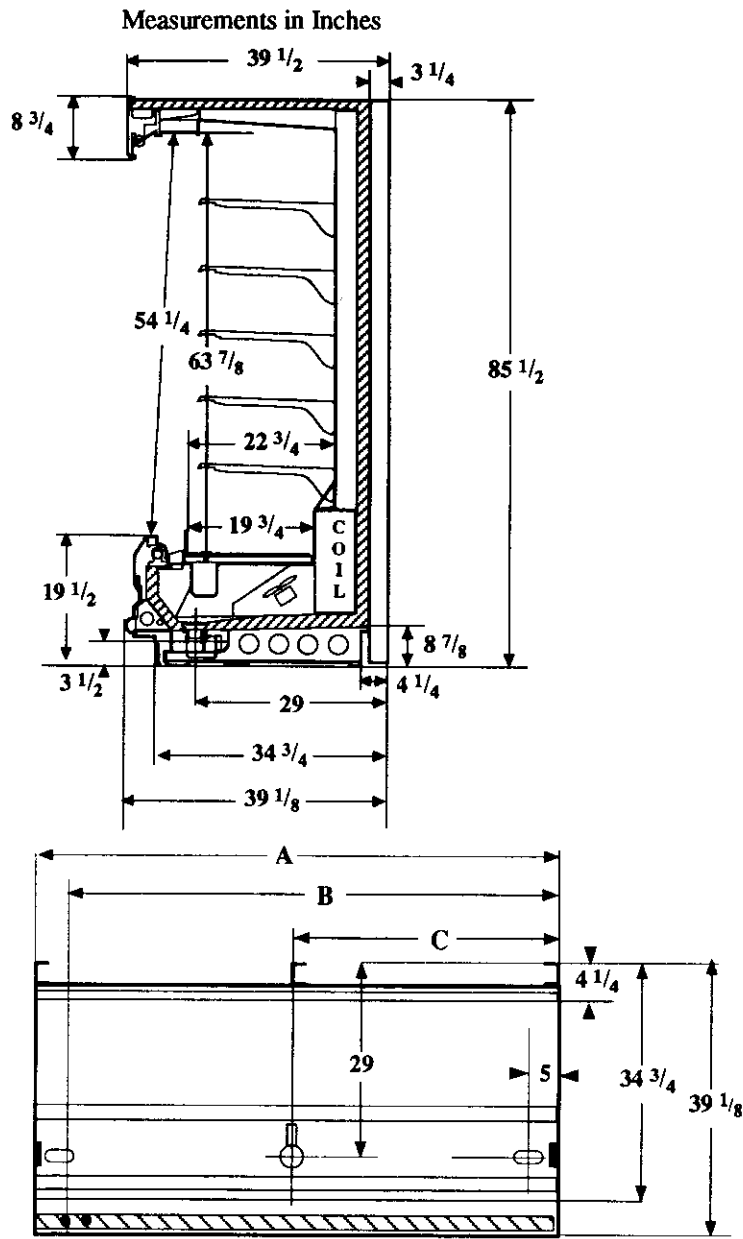

Dimension	8' Case	12' Case
A	96 1/4	144 3/8
B	92	140 1/8
C	48 1/8	72 1/8

Refrigeration Data

Discharge Air °F	32
Evaporator °F	21
Unit Sizing °F	19
BTU/HR/FOOT	
Shelf Depth (In.)	20
Parallel	1565
Satellite	Not Applied
Conventional	1645

Defrost Data

Frequency Hrs	6
ELECTRIC	
Temp Term °F	48
Failsafe Min	26
REVERSE AIR	
Temp Term °F	NA
Failsafe Min	
GAS	
Duration Min	14
OFFTIME	
Duration Min	40

Conventional Controls

Low Pressure Backup Control		
CI/CO (PSIG)		
R-22 37/27	R-502	45/35
Indoor Condenser only, Pressure		
Defrost Termination (PSIG)		
R-22 70	R-502	82

Physical Data

Merchandiser		
Drip Pipe (Ins)		1 1/2
Liquid Line (Ins)		3/8
Suction Line (Ins)		1 1/8
Evaporator Estimated Charge		
Length	R-22	R-502
	(lbs)	(lbs)
8	12	13
12	19	20

Length Added to Lineup by Ends and Partitions

Each End (Ins) 1 1/2

Each Insulated

Partition (Ins) 1 1/2

Vision ND6L UNLIT Dairy
--

Electrical Data

Merchandiser	8Ft	12Ft		
Number of Fans - Evaporator	3	4		
	Amperes		Watts	
Merchandiser	8Ft	12Ft	8Ft	12Ft
Enrg Eff Fans Standard	0.78	1.04	81	108
Constant on Anti-sweat Heaters	NA			
Cycling Anti-sweat Heaters	NA			
Min. Circuit Ampacity	0.98	1.24		
Max. Over Current Protection	20	20		
Supplemental Gas Heaters	NA			
208V 1Φ Electric Defrost	5.2	7.8	1082	1622
120V 1Φ Supplemental Rev. Air	NA			

Standard Lighting

1 Row Canopy				
Interior Ledge Light				
Advance	2.15	3.80	257	440
Valmont (GE)	—	4.20	—	514
Magnatec/Universal	2.10	3.60	257	430

Revised 12-15-93

HUSSMANN CORPORATION • BRIDGETON, MO 63044