

Meat and Deli, Single Curved Hinged Glass, 3 Display Levels
(including Mezzanine Shelves), Humidification, and Rear Sliding Doors

Vision NEBSHM
Meat

Refrigeration Data

Discharge Temp °F	24
Evaporator °F	20
Unit Sizing °F	18
<i>BTU/HR/FOOT</i>	
Parallel	489
Satellite	502
Conventional	515

Defrost Data

Frequency Hrs	24
<i>ELECTRIC</i>	
Temp Term °F	NA
Failsafe Min	NA
<i>REVERSE AIR</i>	
Temp Term °F	NA
Failsafe Min	NA
<i>GAS</i>	
Duration Min	NA
<i>OFFTIME</i>	
Duration Min	90

Conventional Controls

Low Pressure Backup Control	
CI/CO (PSIG)	
R-22 36/26	R-502 44/34
Indoor Condenser only, Pressure	
Defrost Termination (PSIG)	
R-22 76	R-502 89

Physical Data

Merchandiser	
Drip Pipe (in.)	1 1/2
Liquid Line (in.)	3/8
Suction Line (in.)	7/8

Evaporator Estimated Charge

Length	R-22 (lbs)	R-502 (lbs)
8'	17	17
12'	25	25

Length Added to Lineup by Ends and Partitions

Each End (in.)	1 1/2
Each Partition (in.)	1 1/2

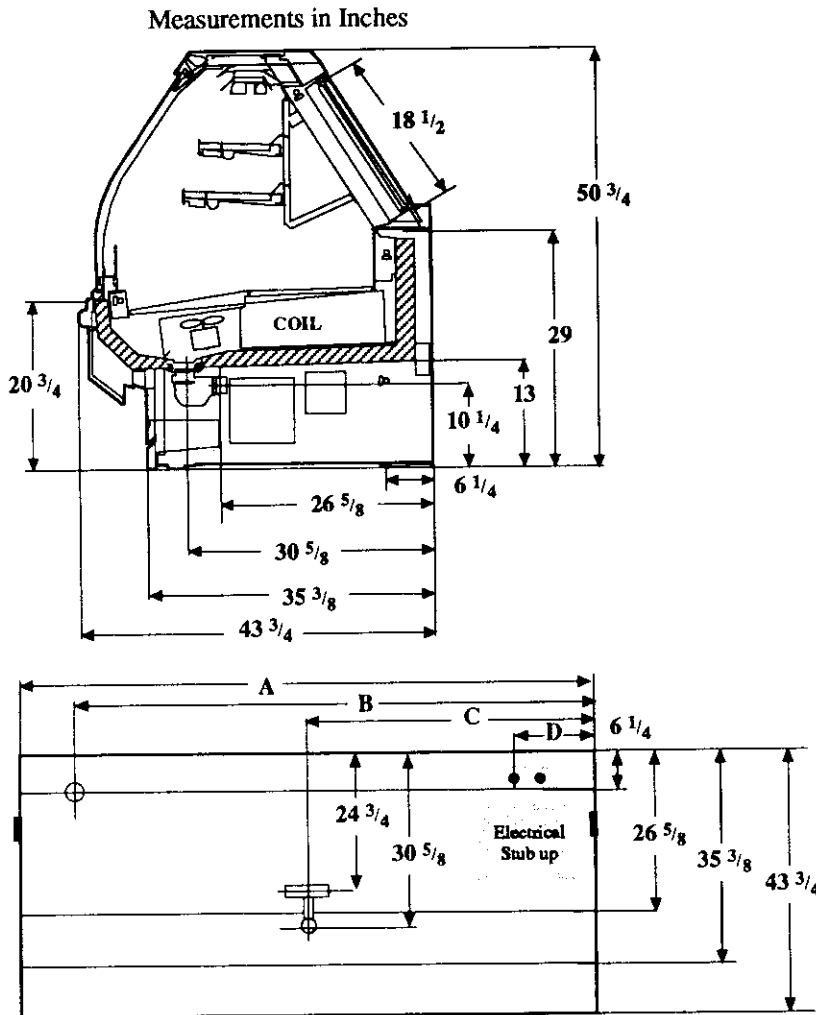

<ul style="list-style-type: none"> ○ Electrical Service ○ Waste Outlet ○ Refrigeration Outlet ■ Passageway Port 	Dimension	8' Case	12' Case
	A	96 1/4	144 3/8
	B	84 1/4	138 3/8
	C	48 1/8	72 1/4
	D	8 1/2	8 1/2

Revised 12-15-93

Vision NEBSHM Meat

Electrical Data

Merchandiser	8Ft	12Ft
Number of Fans - Evaporator	2	3

Merchandiser	Amperes		Watts	
	8Ft	12Ft	8Ft	12Ft
Fans				
Standard	1.2	1.8	80	120
Energy Efficient	NA			
Constant on Anti-sweat Heaters	0.7	1.1	84	132
Cycling Anti-sweat Heaters	NA			
Supplemental Gas Heaters	NA			
Humidifier System	4.0	4.0	230	230
Min. Circuit Ampacity				
With Standard Fans	2.1	3.1		
With Energy Efficient Fans	NA			
Max. Over Current Protection	20	20		
208V 1Φ Electric Defrost	NA			
120V 1Φ Supplemental Rev. Air	NA			

Standard Lighting*

1 Row Canopy	[2.0]	[3.0]		
Valmont (GE)	0.66	0.99	80	120
Robertson	0.66	0.99	No Listing	No Listing

*[] = Serial Plate Amperage includes wire harness for 2 rows of lighted mezzanine shelves.