

Double Curved Hinged Glass, 3 Display Levels (including Mezzanine Shelves), Gravity Coil, Induction Fan and Coil for Bottom Level, Rear Sliding Doors

Vision **NEGDH**
Meat

Refrigeration Data

Discharge Temp °F	24
Evaporator °F	21
Unit Sizing °F	19
<i>BTU/HR/FOOT</i>	
Parallel	422
Satellite	434
Conventional	445

Defrost Data

Frequency Hrs	24
<i>ELECTRIC</i>	
Temp Term °F	NA
Failsafe Min	NA
<i>REVERSE AIR</i>	
Temp Term °F	NA
Failsafe Min	NA
<i>GAS</i>	
Duration Min	NA
<i>OFFTIME</i>	
Duration Min	90

Conventional Controls

Low Pressure Backup Control	
C/CO (PSIG)	
R-22 37/27	R-502 45/35
Indoor Condenser only, Pressure Defrost Termination (PSIG)	
R-22 76	R-502 89

Physical Data

Merchandiser	
Drip Pipe (in.)	1 1/2
Liquid Line (in.)	3/8
Suction Line (in.)	5/8

Evaporator Estimated Charge		
Length	R-22	R-502
	(lbs)	(lbs)
8'	15	15
12'	22	22

Length Added to Lineup by Ends and Partitions

Each End (in.)	1 1/2
Each Insulated Partition (in.)	1 1/2

Measurements in Inches

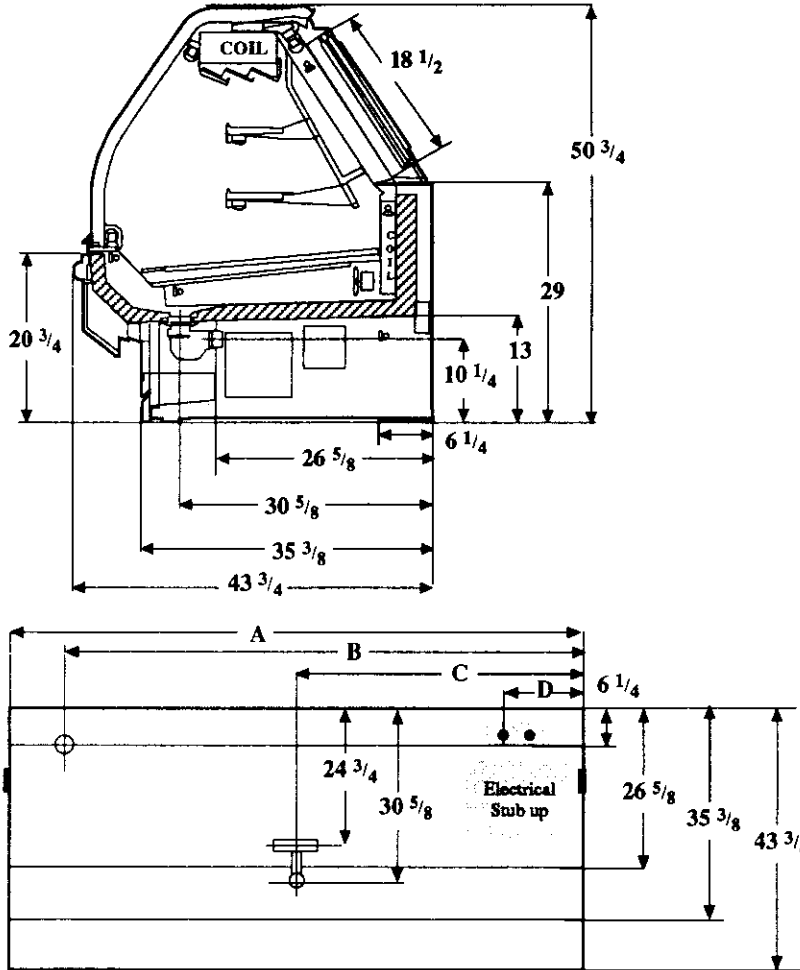

○	Electrical Service	Dimension	8' Case	12' Case
○	Waste Outlet	A	96 1/4	144 3/8
○	Refrigeration Outlet	B	84 1/4	138 3/8
■	Passageway Port	C	48 1/8	72 1/4
		D	8 1/2	8 1/2

Revised 12-15-93