

Single Level Wide Island Display

Vision NFCW
Meat

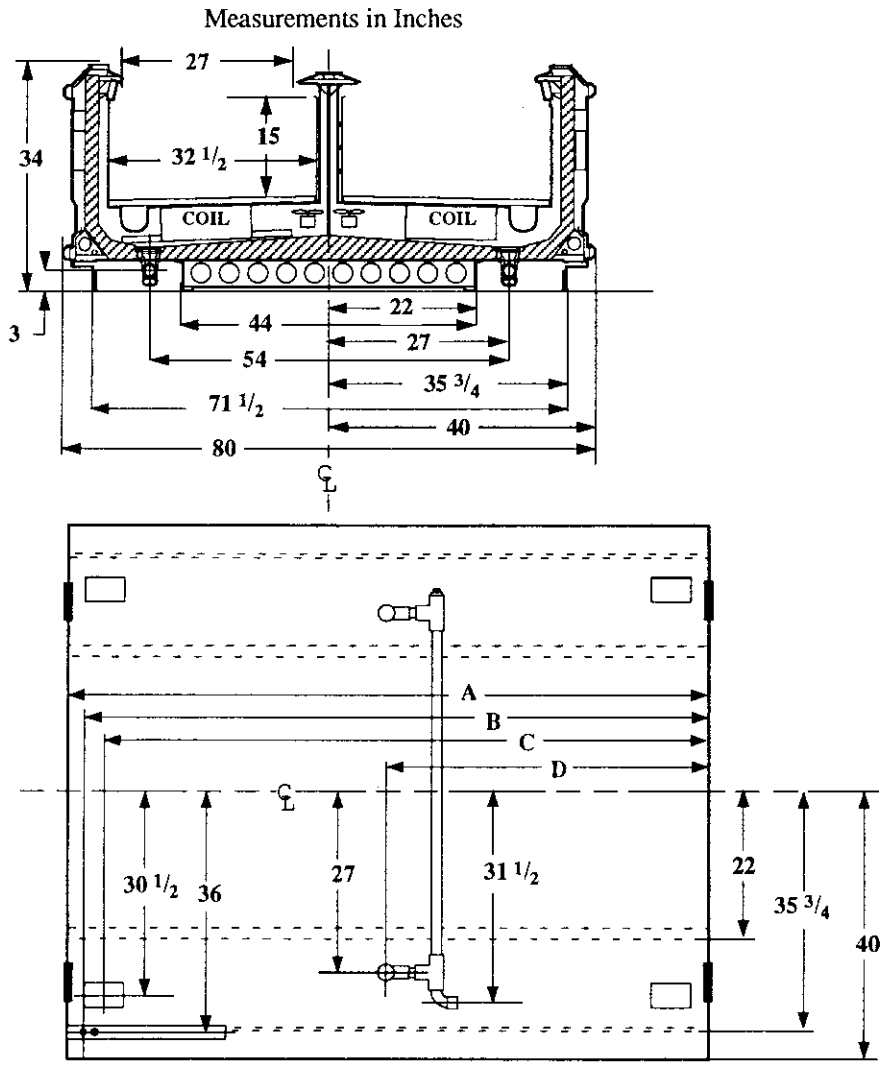

	Dimension	8' Case	12' Case
●	A	96 3/8	144 1/2
○	B	93 3/4	141 7/8
□	C	91 3/4	139 7/8
┆	D	48 1/4	72 1/4

Refrigeration Data

Discharge Air °F	20	22	*24
Evaporator °F	14	16	18
Unit Sizing °F	12	14	16
BTU/HR/FOOT**			
Parallel	515	500	485
Satellite	525	520	495
Conventional	540	525	510

* Hussmann recommends.
** Includes BOTH sides.

Defrost Data

Frequency Hrs	24
ELECTRIC	
Temp Term °F	52
Failsafe Min	60
REVERSE AIR	
Temp Term °F	48
Failsafe Min	60
GAS	
Duration Min	20
OFFTIME	
Duration Min	NA

Conventional Controls

Low Pressure Backup Control		
CI/CO (PSIG)		
R-22	34/24	R-502 42/32

Indoor Condenser only, Pressure Defrost Termination (PSIG)
R-22 NA R-502 NA

Physical Data

Merchandiser	
Drip Pipe (ins)	1 1/2
Liquid Line (ins)	3/8
Suction Line (ins)	7/8

Evaporator Estimated Charge

Length	R-22 (lbs)	R-502 (lbs)
8	17	13
12	21	19

Length Added to Lineup by Ends and Partitions

Each End (ins)	6 1/2
Each Insulated	
Partition (ins)	1 1/2

Vision NFCW Meat

Electrical Data

Merchandiser	Number of Fans - Evaporator		Watts	
	8Ft	12Ft	8Ft	12Ft
	4	6		
Merchandiser	Amperes		Watts	
	8Ft	12Ft	8Ft	12Ft
Fans				
Standard	2.40	3.60	160	240
Energy Efficient	0.80	1.20	80	120
Reverse Air	1.24	1.96	120	180
Constant on Anti-sweat Heaters	1.60	2.40	192	288
Cycling Anti-sweat Heaters	NA			
Min. Circuit Ampacity				
With Standard Fans	4.20	6.20		
With Energy Efficient Fans	2.60	3.80		
With Reverse Air Fans	3.04	4.56		
Max. Over Current Protection	20	20		
Supplemental Gas Heaters	0.4	0.4	50	50
208V 1Φ Electric Defrost	16.4	24.2	3411	5034
120V 1Φ Supplemental Rev. Air	14.2	21.0	1704	2520

Standard Lighting

None