

MINIMUM CLEARANCE REQUIREMENTS:

ACTUAL CLEARANCE REQUIREMENTS ARE DEPENDENT UPON AUTHORITY HAVING JURISDICTION AND MAY EXCEED DIMENSIONS SHOWN.

A) 42.0" CLEARANCE BETWEEN CONTROL PANEL AND ANY WALL

B) 48.0" CLEARANCE BETWEEN CONTROL PANEL AND ANY LIVE PANEL

C) 30.0" CLEARANCE FOR WORK SPACE, ADJUSTMENT AND REPLACEMENT OF PARTS

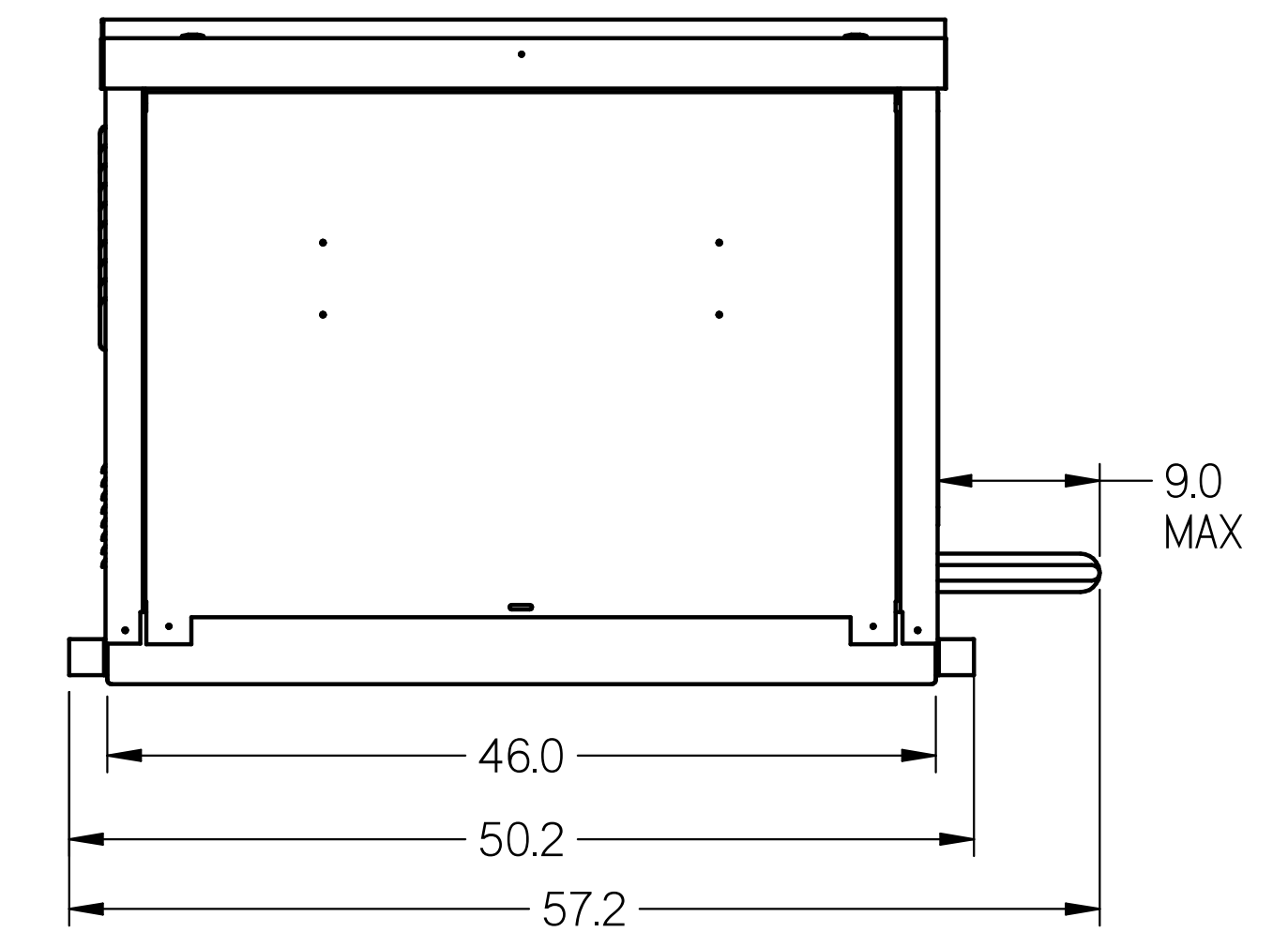
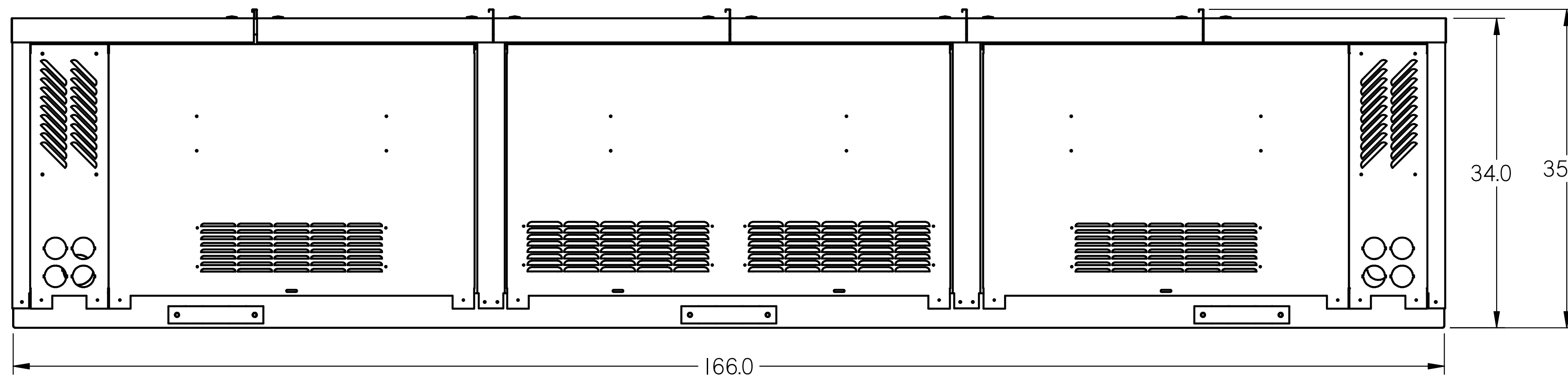
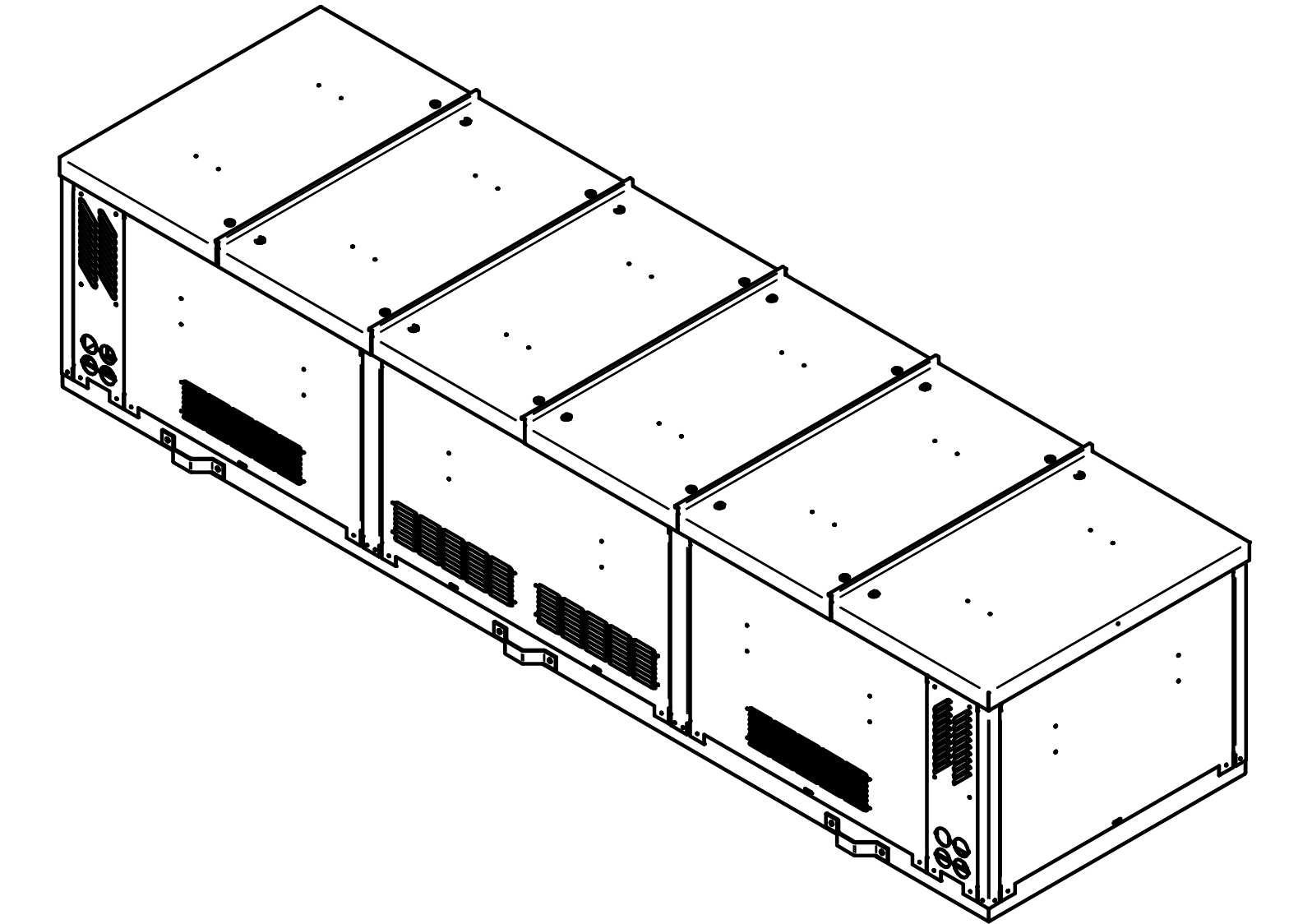
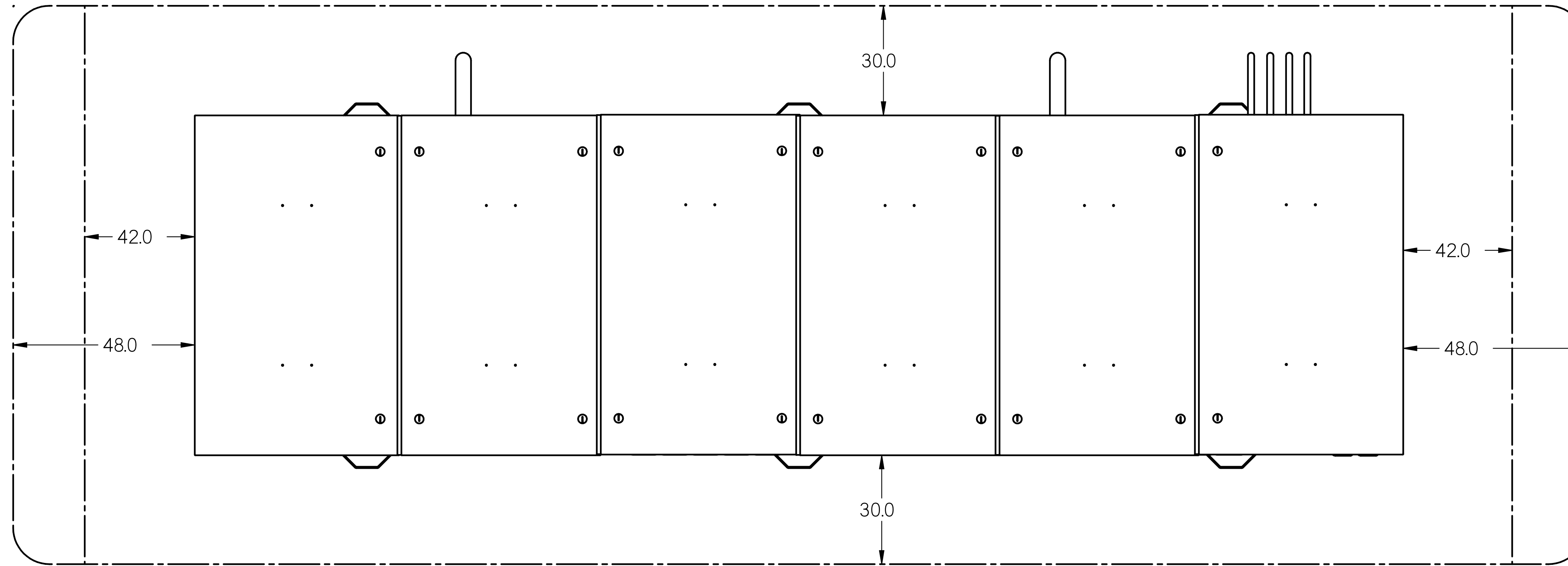

NOTES:

1. IT IS THE RESPONSIBILITY OF THE INSTALLING CONTRACTOR TO ENSURE THAT THE FINAL EQUIPMENT INSTALLATION MEETS ALL APPLICABLE CODE REQUIREMENTS.
2. ILLUSTRATION SHOWN IS FOR GENERAL REPRESENTATION ONLY. ACTUAL PRODUCT WILL VARY DEPENDENT UPON APPLICATION.
3. OVERALL DIMENSIONS: 166.0 L X 57.2 W X 35.1 T.
4. APPROXIMATE WEIGHT OF THE UNIT = 2500 LBS
5. OLP: OUT DOOR LOW PROFILE, A PRODUCT OF HUSSMANN CORP.

UNLESS OTHERWISE SPECIFIED DIMENSIONS ARE IN INCHES.	HUSSMANN [®]	
	ASSY OLP 6 COMPR UNIT	
THIRD ANGLE PROJECTION	P/N PD-000000092	REV A
SHEET 1 OF 2		SWN 1.0 SHEET SIZE D

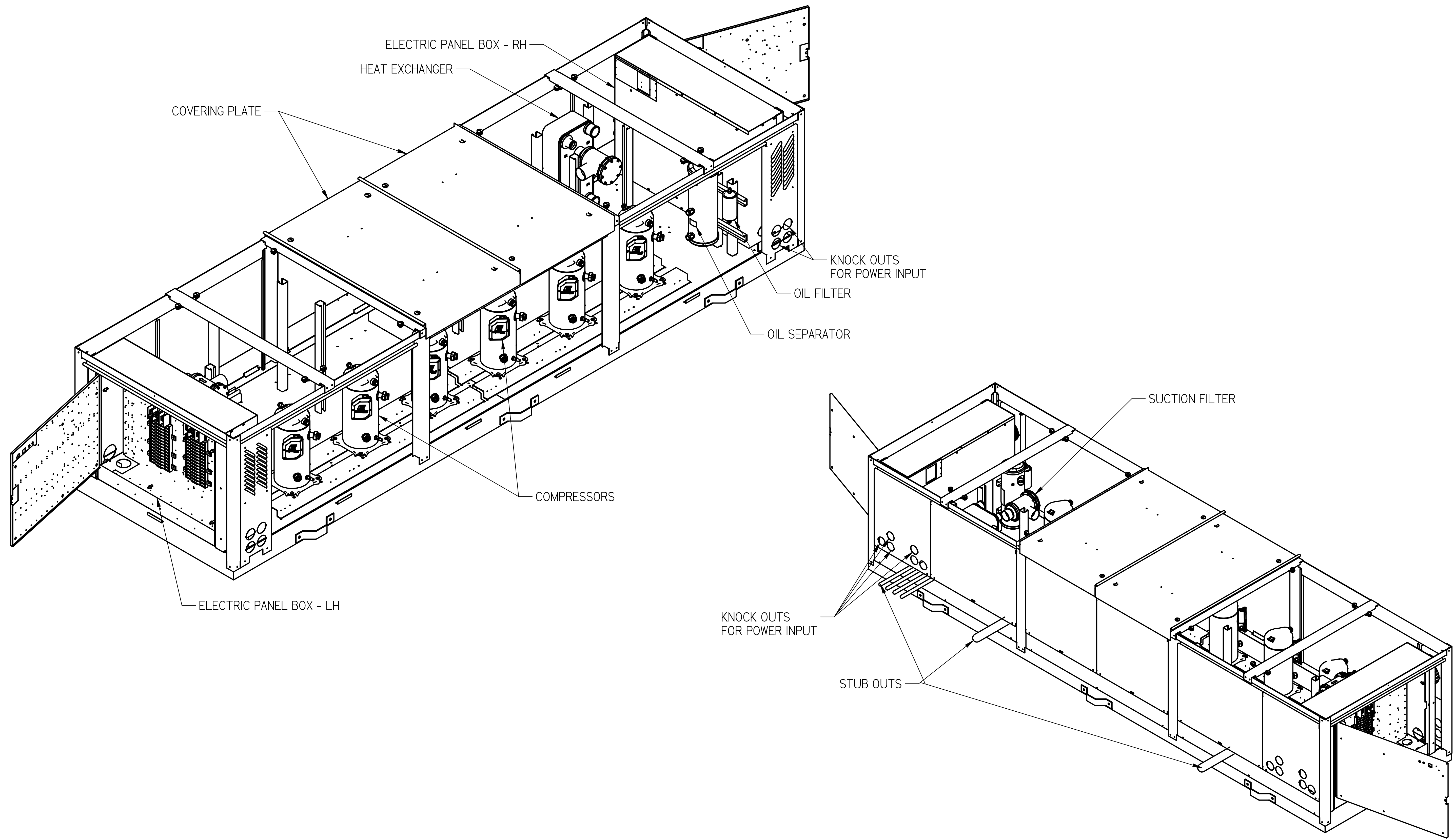

NOTES:

1. IT IS THE RESPONSIBILITY OF THE INSTALLING CONTRACTOR TO ENSURE THAT THE FINAL EQUIPMENT INSTALLATION MEETS ALL APPLICABLE CODE REQUIREMENTS.
2. ILLUSTRATION SHOWN IS FOR GENERAL REPRESENTATION ONLY. ACTUAL PRODUCT WILL VARY DEPENDENT UPON APPLICATION.
3. OVERALL DIMENSIONS: 166.0 L X 57.2 W X 35.1 T.
4. APPROXIMATE WEIGHT OF THE UNIT = 2500 LBS
5. OLP: OUT DOOR LOW PROFILE, A PRODUCT OF HUSSMANN CORP.

UNLESS OTHERWISE SPECIFIED DIMENSIONS ARE IN INCHES.	HUSSMANN [®]	
	ASSY OLP 6 COMPR UNIT	
	THIRD ANGLE PROJECTION	P/N PD-000000092 REV A
SHEET 2 OF 2		

SWN 1.0 SHEET SIZE D