

GPM (Armstrong)	Motor HP	Weight, Lbs. (operating & shipping)	Voltage	MCA (Min. Circuit Ampacity)	MOPD (Max. Overcurrent Protection)
150	7.5	2500 / 2200	208/230	31	50
			460	14	25
			575	12	20
200	10	2500 / 2200	208/230	39	60
			460	18	30
			575	14	25

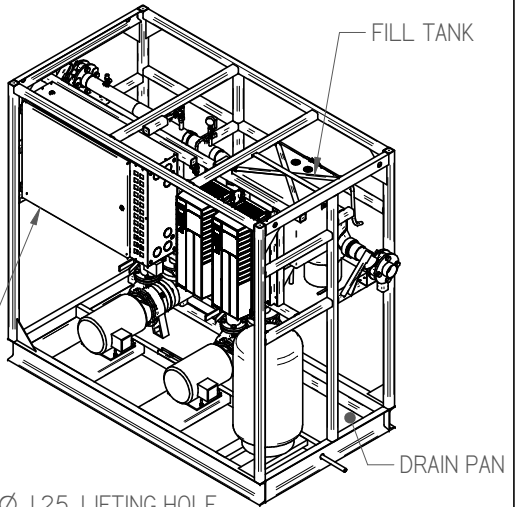

TOP VIEW AND CLEARANCE REQUIREMENTS ON SHEET 3

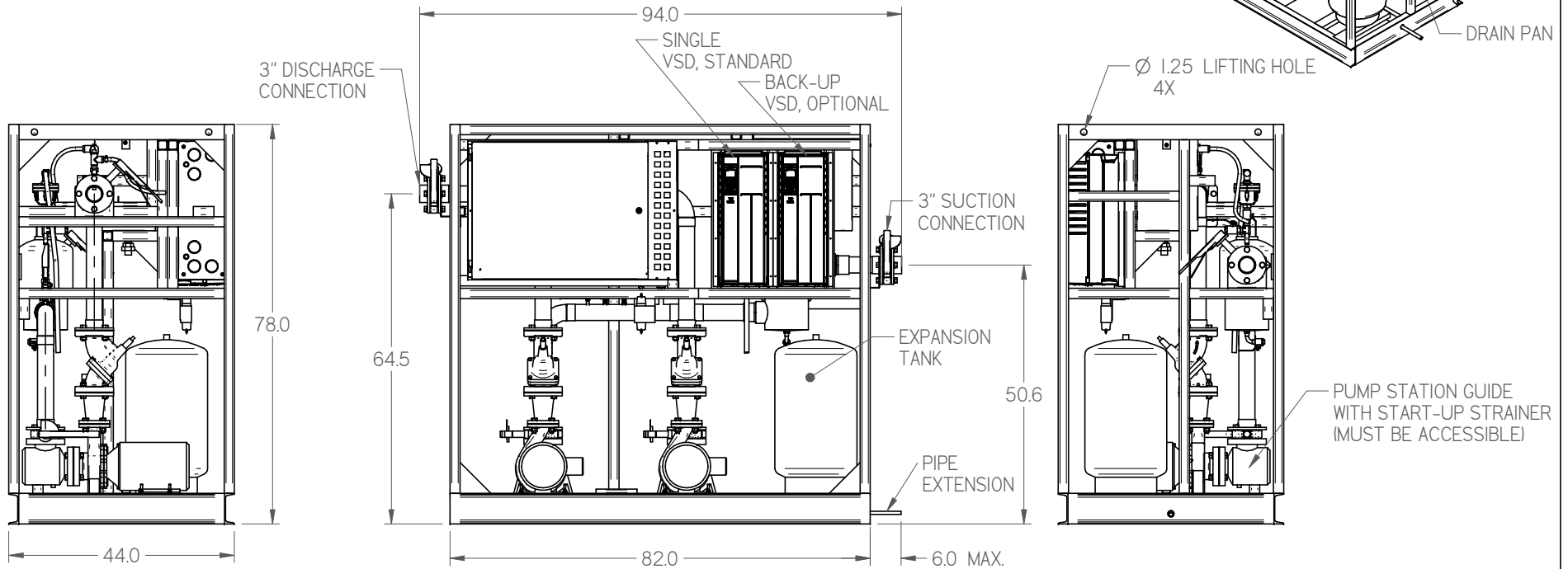

NOTES:

1. IT IS THE RESPONSIBILITY OF THE INSTALLING CONTRACTOR TO ENSURE THAT THE FINAL EQUIPMENT INSTALLATION MEETS ALL APPLICABLE CODE REQUIREMENTS.
2. ILLUSTRATION SHOWN IS FOR GENERAL REPRESENTATION ONLY. ACTUAL PRODUCT WILL VARY DEPENDENT UPON APPLICATION.
3. OVERALL DIMENSIONS: 94.0 L X 44.0 W X 78.0 H.

DIMENSIONS ARE IN INCHES.
DATE DRAWN: 2017/09/14

HUSSmann®

PUMP STATION-150
AND 200 GPM

ARMSTRONG

DOC PD-00000022



THIRD
ANGLE
PROJECTION

INFORMATION SUBJECT TO CHANGE

SHEET 1 OF 3

REV B

SHEET SUBMITTAL SHEET SIZE D

MINIMUM CLEARANCE REQUIREMENTS:

ACTUAL CLEARANCE REQUIREMENTS ARE DEPENDENT UPON AUTHORITY HAVING JURISDICTION, AND MAY EXCEED DIMENSIONS SHOWN.

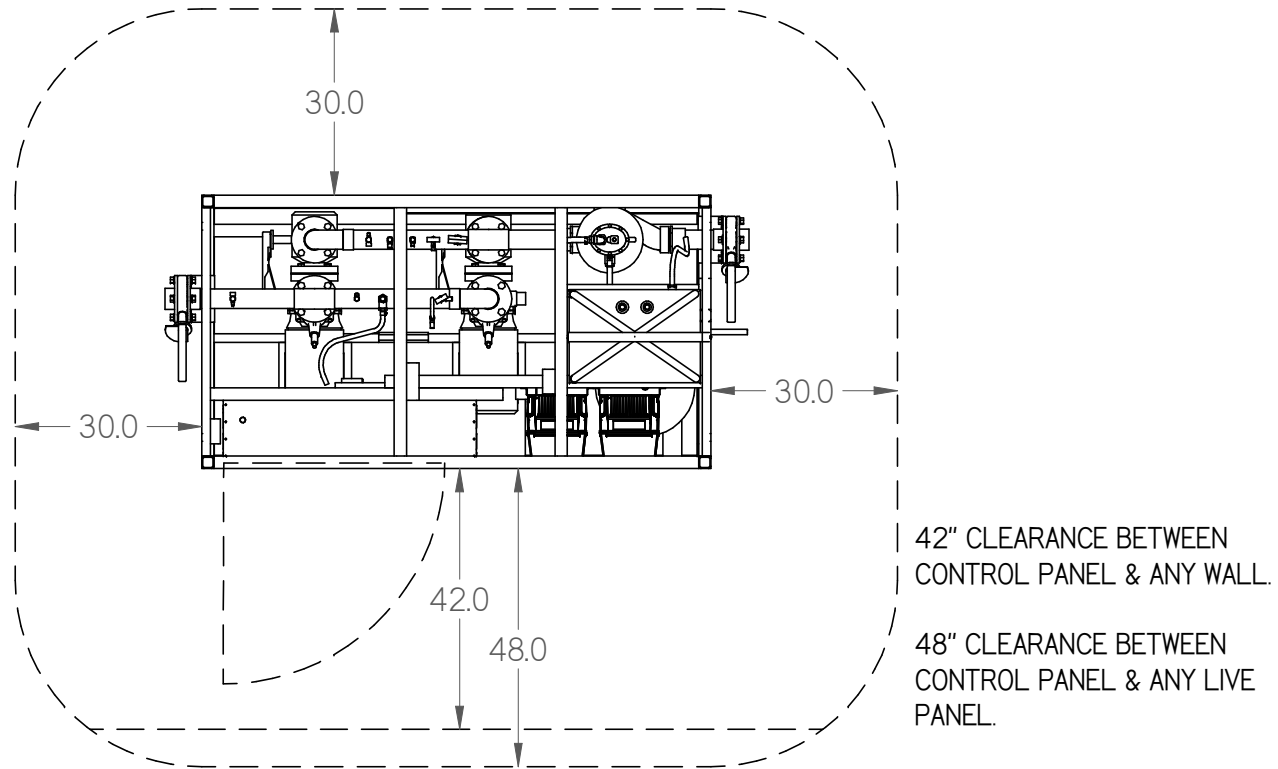

NOTES:

1. IT IS THE RESPONSIBILITY OF THE INSTALLING CONTRACTOR TO ENSURE THAT THE FINAL EQUIPMENT INSTALLATION MEETS ALL APPLICABLE CODE REQUIREMENTS.
2. ILLUSTRATION SHOWN IS FOR GENERAL REPRESENTATION ONLY. ACTUAL PRODUCT WILL VARY DEPENDENT UPON APPLICATION.
3. OVERALL DIMENSIONS: 94.0 L X 44.0 W X 78.0 H.

DIMENSIONS ARE IN INCHES.
DATE DRAWN: 2017/09/14

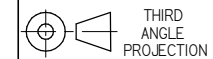

THIRD
ANGLE
PROJECTION

INFORMATION SUBJECT TO CHANGE

SHEET 3 OF 3

HUSSmann®

PUMP STATION-150
AND 200 GPM
ARMSTRONG

DOC PD-00000022 REV B

SWIN10 SUBMITTAL SHEET SIZE D

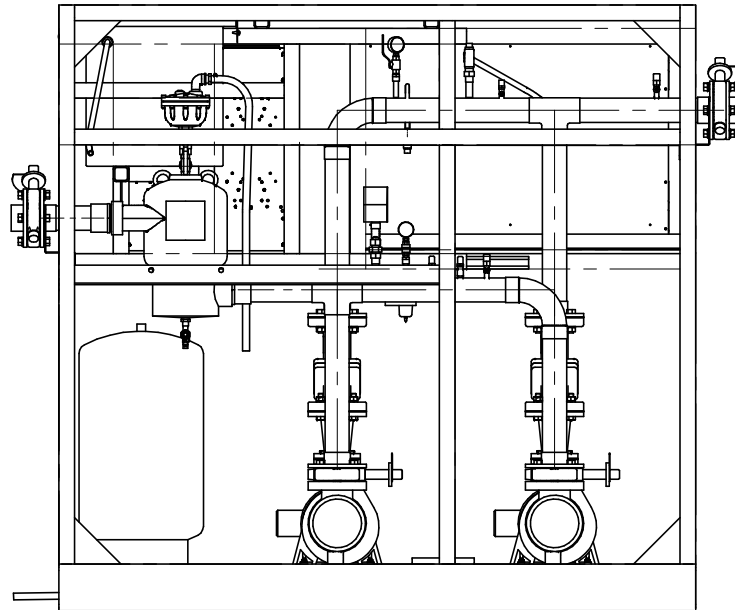

BACK VIEW

NOTES:

1. IT IS THE RESPONSIBILITY OF THE INSTALLING CONTRACTOR TO ENSURE THAT THE FINAL EQUIPMENT INSTALLATION MEETS ALL APPLICABLE CODE REQUIREMENTS.
2. ILLUSTRATION SHOWN IS FOR GENERAL REPRESENTATION ONLY. ACTUAL PRODUCT WILL VARY DEPENDENT UPON APPLICATION.
3. OVERALL DIMENSIONS: 94.0 L X 44.0 W X 78.0 H.

DIMENSIONS ARE IN INCHES.
DATE DRAWN: 2017/09/14



THIRD
ANGLE
PROJECTION

INFORMATION SUBJECT TO CHANGE

SHEET 2 OF 3

HUSSmann®

PUMP STATION-150
AND 200 GPM
ARMSTRONG

DOC PD-00000022 REV B

SHEET 2 OF 3 SUBMITTAL SHEET SIZE D