

GPM (Armstrong)	Motor HP	Weight, Lbs. (operating)	Voltage	MCA (Min. Circuit Ampacity)	MOPD (Max. Overcurrent Protection)
250	10	3000 / 2600	208/230	39	60
			460	18	30
			575	14	25
300	15	3500 / 3100	208/230	58	100
			460	27	40
			575	22	35
350	15	3500 / 3100	208/230	58	100
			460	27	40
			575	22	35

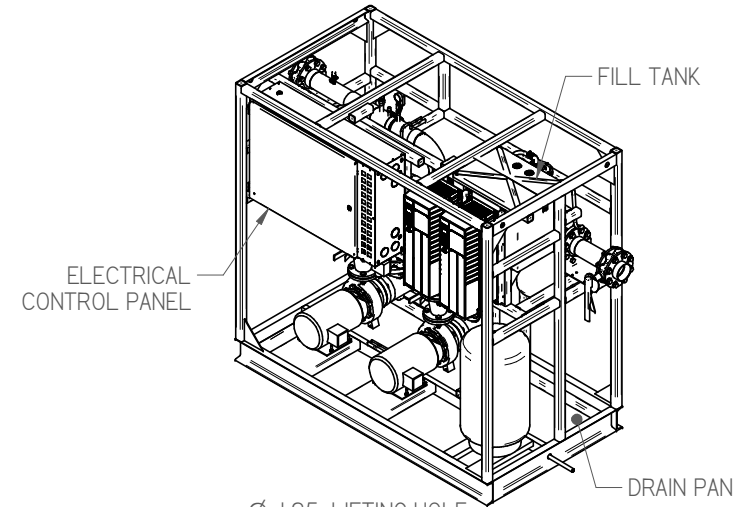

TOP VIEW AND CLEARANCE REQUIREMENTS ON SHEET 3

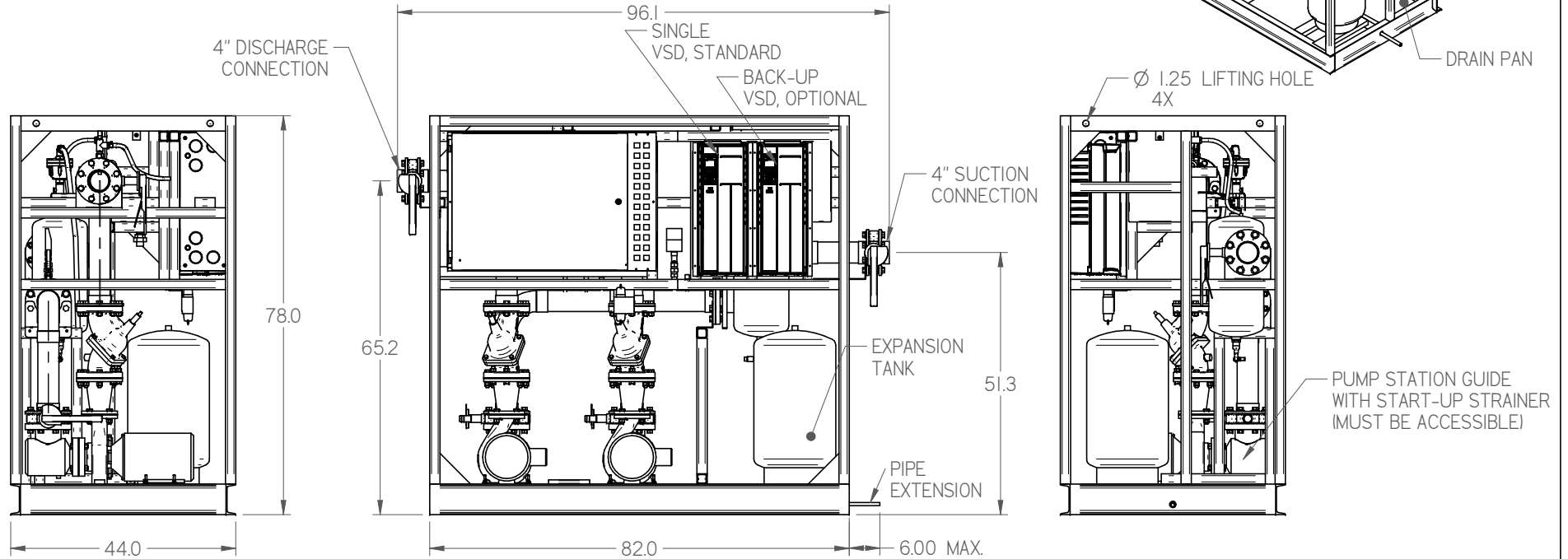

NOTES:

1. IT IS THE RESPONSIBILITY OF THE INSTALLING CONTRACTOR TO ENSURE THAT THE FINAL EQUIPMENT INSTALLATION MEETS ALL APPLICABLE CODE REQUIREMENTS.
2. ILLUSTRATION SHOWN IS FOR GENERAL REPRESENTATION ONLY. ACTUAL PRODUCT WILL VARY DEPENDENT UPON APPLICATION.
3. OVERALL DIMENSIONS: 96.1 L X 44.0 W X 78.0 H.

DIMENSIONS ARE IN INCHES. DATE DRAWN: 2017/09/14	THIRD ANGLE PROJECTION	HUSSMANN® PUMP STATION-250, 300 AND 350 GPM ARMSTRONG
		DOC PD-00000023 REV B

INFORMATION SUBJECT TO CHANGE

SHEET 1 OF 3

SHEET SUBMITTAL SHEET SIZE D

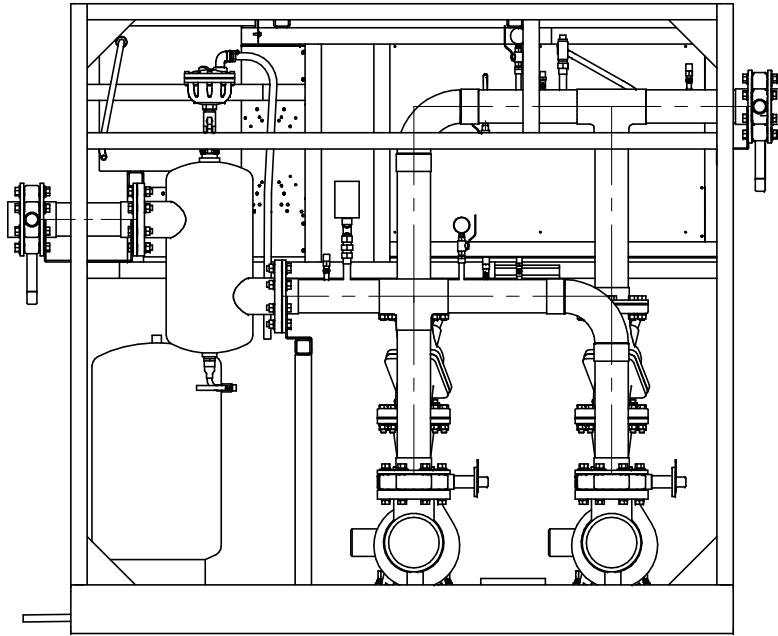

BACK VIEW

NOTES:

1. IT IS THE RESPONSIBILITY OF THE INSTALLING CONTRACTOR TO ENSURE THAT THE FINAL EQUIPMENT INSTALLATION MEETS ALL APPLICABLE CODE REQUIREMENTS.
2. ILLUSTRATION SHOWN IS FOR GENERAL REPRESENTATION ONLY. ACTUAL PRODUCT WILL VARY DEPENDENT UPON APPLICATION.
3. OVERALL DIMENSIONS: 96.1 L X 44.0 W X 78.0 H.

DIMENSIONS ARE IN INCHES.
DATE DRAWN: 2017/09/14



HUSSmann®

PUMP STATION-250,
300 AND 350 GPM
ARMSTRONG

INFORMATION SUBJECT TO CHANGE

SHEET 2 OF 3

DOC PD-000000023 REV B

SHEET SUBMITTAL SHEET SIZE D

MINIMUM CLEARANCE REQUIREMENTS:
 ACTUAL CLEARANCE REQUIREMENTS
 ARE DEPENDENT UPON AUTHORITY
 HAVING JURISDICTION, AND MAY EXCEED
 DIMENSIONS SHOWN.

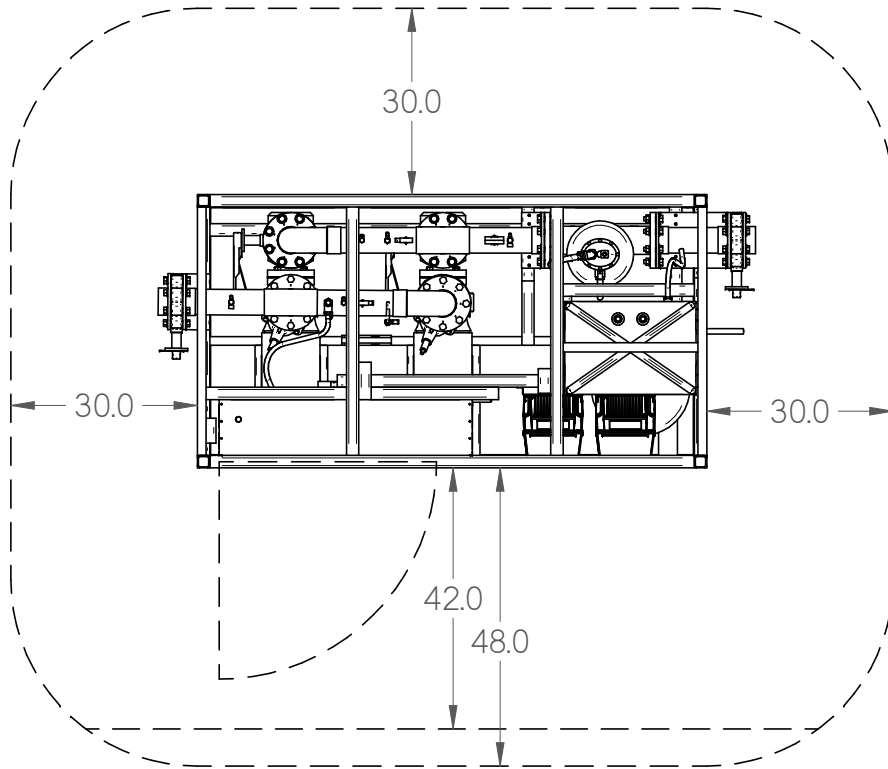

42" CLEARANCE BETWEEN
 CONTROL PANEL & ANY WALL.

48" CLEARANCE BETWEEN
 CONTROL PANEL & ANY LIVE
 PANEL.

NOTES:

1. IT IS THE RESPONSIBILITY OF THE INSTALLING CONTRACTOR TO ENSURE THAT THE FINAL EQUIPMENT INSTALLATION MEETS ALL APPLICABLE CODE REQUIREMENTS.
2. ILLUSTRATION SHOWN IS FOR GENERAL REPRESENTATION ONLY. ACTUAL PRODUCT WILL VARY DEPENDENT UPON APPLICATION.
3. OVERALL DIMENSIONS: 96.1 L X 44.0 W X 78.0 H.

INFORMATION SUBJECT TO CHANGE

DIMENSIONS ARE IN INCHES. DATE DRAWN: 2017/09/14  THIRD ANGLE PROJECTION	HUSSmann®	
	PUMP STATION-250, 300 AND 350 GPM ARMSTRONG	
SHEET 3 OF 3		DOC PD-00000023 REV B

SHEET SUBMITTAL SHEET SIZE D