

GPM (B & G)	Motor HP	Weight, Lbs. (operating)	Voltage	MCA (Min. Circuit Ampacity)	MOPD (Max. Overcurrent Protection)
150 - 200	7.5	2500 / 2200	208/230	31	50
			460	14	25
			575	12	20

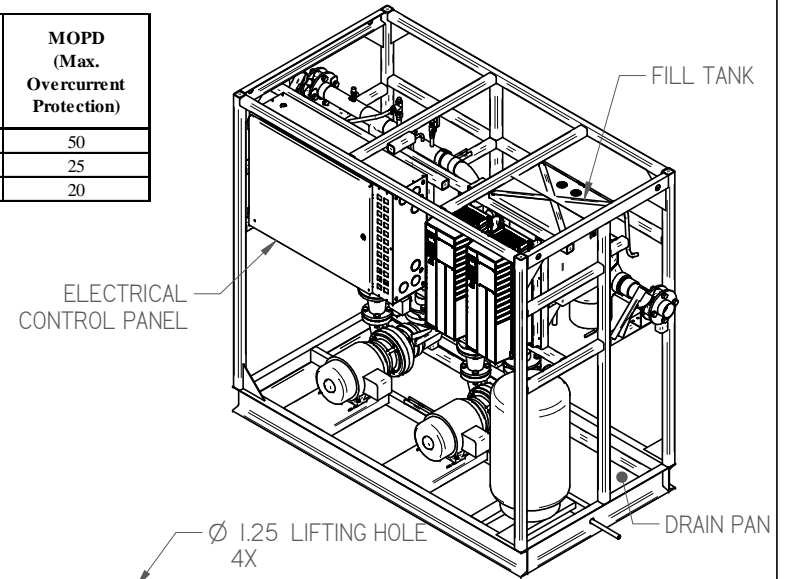

TOP VIEW AND CLEARANCE REQUIREMENTS ON SHEET 3

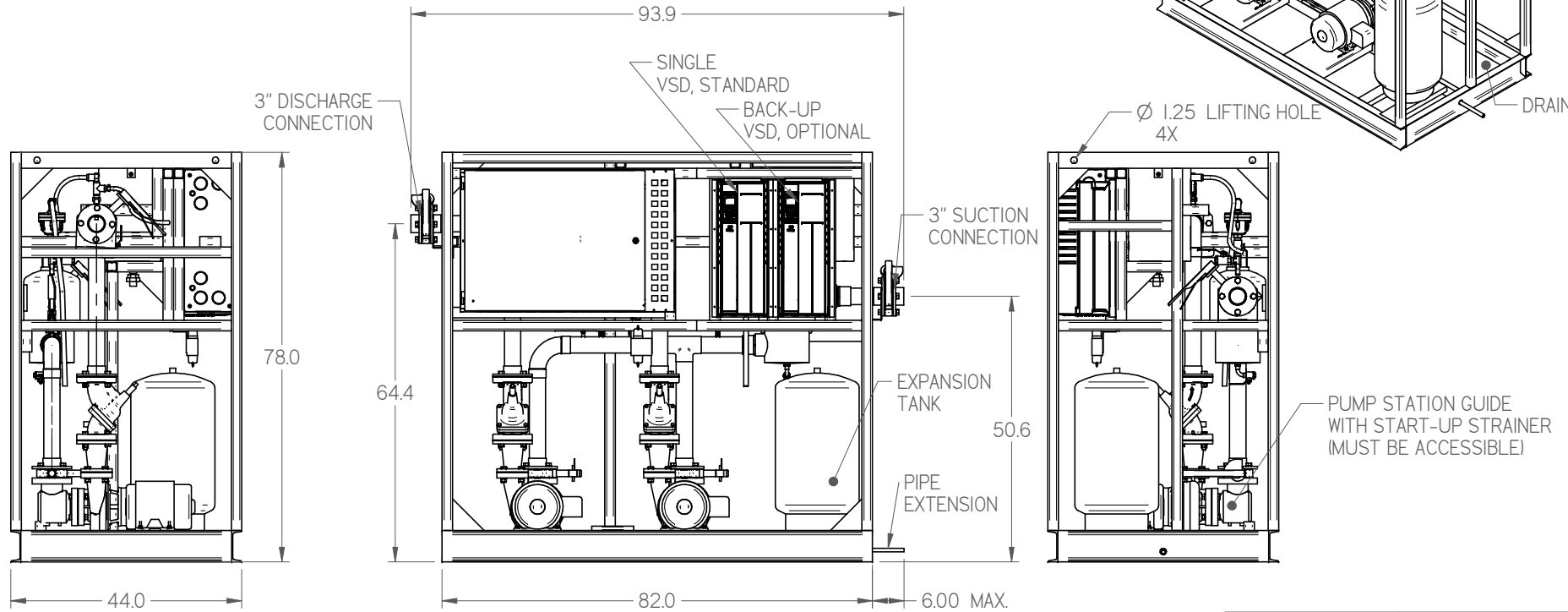

NOTES:

1. IT IS THE RESPONSIBILITY OF THE INSTALLING CONTRACTOR TO ENSURE THAT THE FINAL EQUIPMENT INSTALLATION MEETS ALL APPLICABLE CODE REQUIREMENTS.
2. ILLUSTRATION SHOWN IS FOR GENERAL REPRESENTATION ONLY. ACTUAL PRODUCT WILL VARY DEPENDENT UPON APPLICATION.
3. OVERALL DIMENSIONS: 93.9 L X 44.0 W X 78.0 H.

DIMENSIONS ARE IN INCHES.
DATE DRAWN: 2017/09/15



HUSSmann®

PUMP STATION-200
GPM B AND G

INFORMATION SUBJECT TO CHANGE

SHEET 1 OF 3

DOC PD-000000025 REV B

SWIN10 SUBMITTAL SHEET SIZE D

MINIMUM CLEARANCE REQUIREMENTS:
 ACTUAL CLEARANCE REQUIREMENTS
 ARE DEPENDENT UPON AUTHORITY
 HAVING JURISDICTION, AND MAY EXCEED
 DIMENSIONS SHOWN.

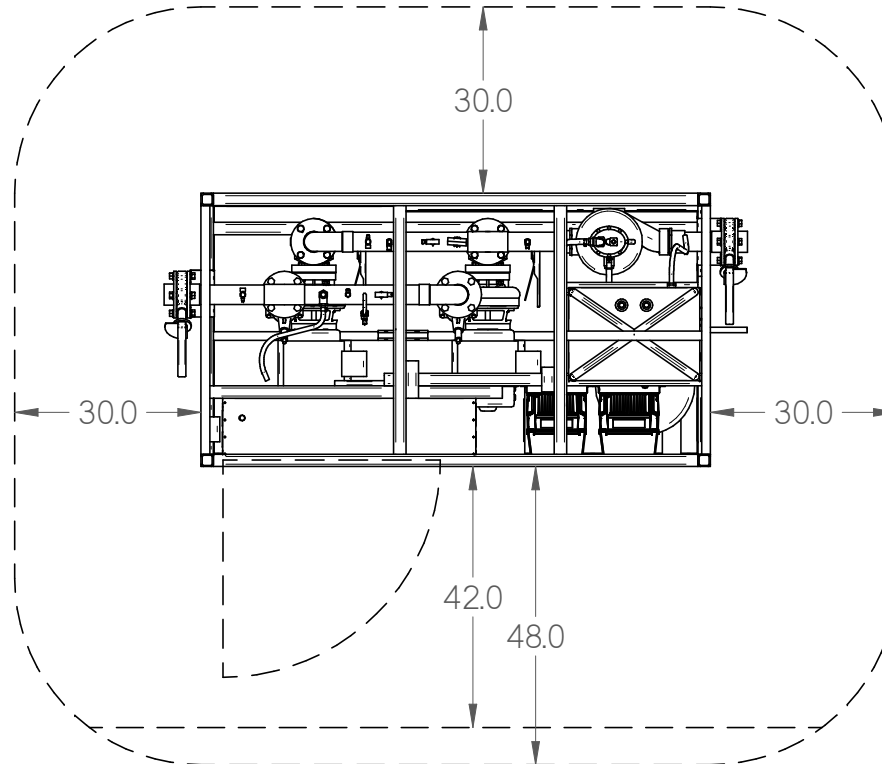

42" CLEARANCE BETWEEN
 CONTROL PANEL & ANY WALL.

48" CLEARANCE BETWEEN
 CONTROL PANEL & ANY LIVE
 PANEL.

NOTES:

1. IT IS THE RESPONSIBILITY OF THE INSTALLING CONTRACTOR TO ENSURE THAT THE FINAL EQUIPMENT INSTALLATION MEETS ALL APPLICABLE CODE REQUIREMENTS.
2. ILLUSTRATION SHOWN IS FOR GENERAL REPRESENTATION ONLY. ACTUAL PRODUCT WILL VARY DEPENDENT UPON APPLICATION.
3. OVERALL DIMENSIONS: 93.9 L X 44.0 W X 78.0 H.

DIMENSIONS ARE IN INCHES.
 DATE DRAWN: 2017/09/15



THIRD
 ANGLE
 PROJECTION

INFORMATION SUBJECT TO CHANGE

SHEET 3 OF 3

HUSSmann®

PUMP STATION-200
 GPM B AND G

DOC PD-000000025 REV B

SHEET SUBMITTAL SHEET SIZE D

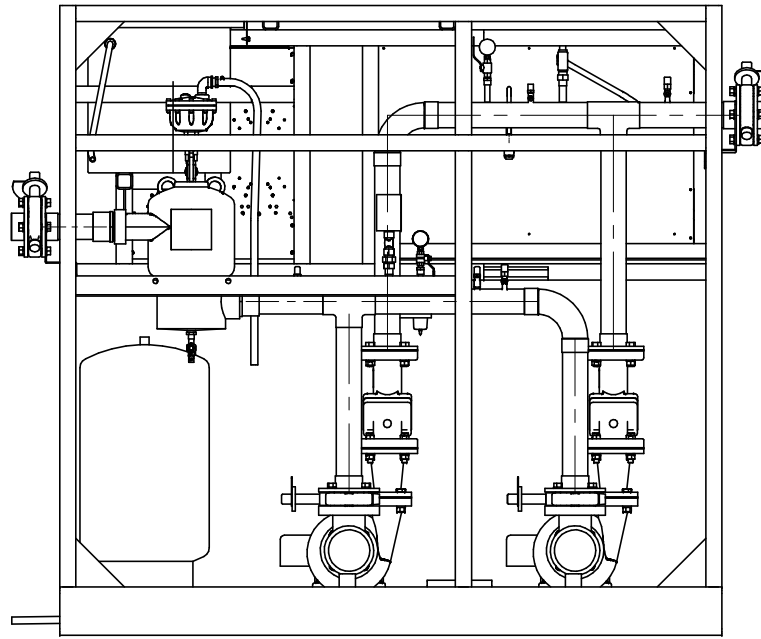

BACK VIEW

NOTES:

1. IT IS THE RESPONSIBILITY OF THE INSTALLING CONTRACTOR TO ENSURE THAT THE FINAL EQUIPMENT INSTALLATION MEETS ALL APPLICABLE CODE REQUIREMENTS.
2. ILLUSTRATION SHOWN IS FOR GENERAL REPRESENTATION ONLY. ACTUAL PRODUCT WILL VARY DEPENDENT UPON APPLICATION.
3. OVERALL DIMENSIONS: 93.9 L X 44.0 W X 78.0 H.

INFORMATION SUBJECT TO CHANGE

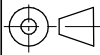
DIMENSIONS ARE IN INCHES. DATE DRAWN: 2017/09/15	HUSSmann®
 THIRD ANGLE PROJECTION	PUMP STATION-200 GPM B AND G
SHEET 2 OF 3	DOC PD-000000025 REV B

SHEET SUBMITTAL SHEET SIZE D