

GPM (Armstrong)	Motor HP	Weight, Lbs. (operating)	Voltage	MCA (Min. Circuit Ampacity)	MOPD (Max. Overcurrent Protection)
350-450	15	3750 / 3300	208/230	58	100
			460	27	40
			575	22	35

## TOP VIEW AND CLEARANCE REQUIREMENTS ON SHEET 3

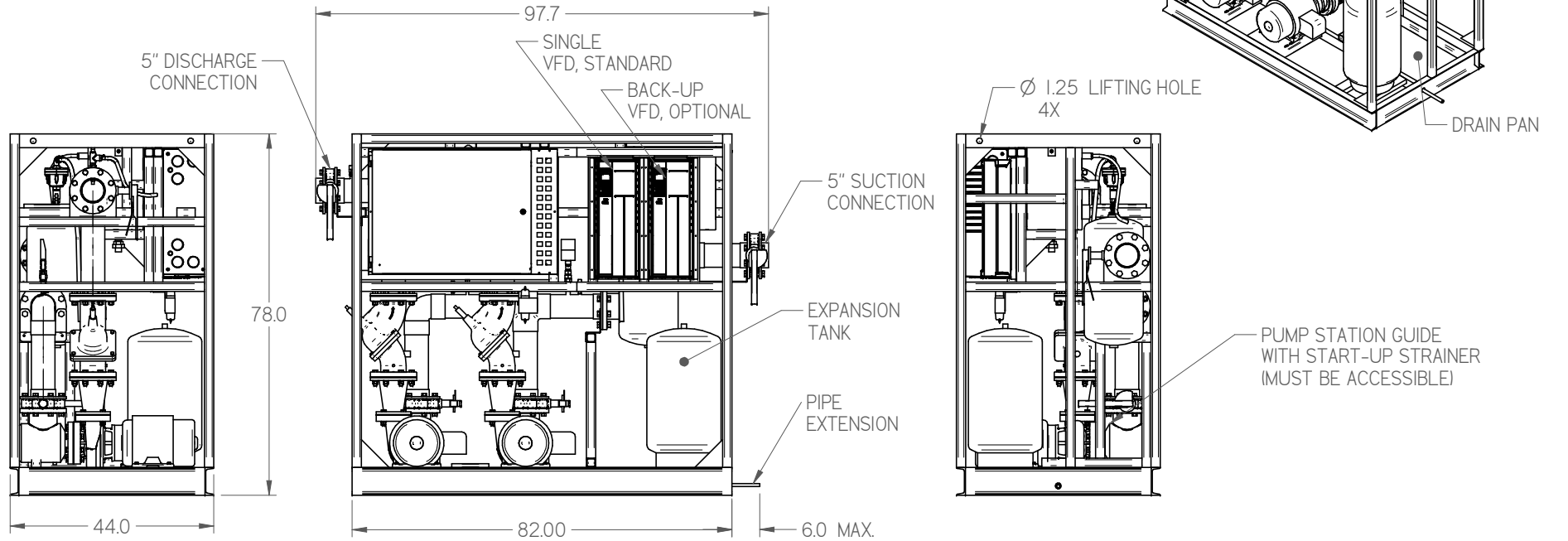

### NOTES:

1. IT IS THE RESPONSIBILITY OF THE INSTALLING CONTRACTOR TO ENSURE THAT THE FINAL EQUIPMENT INSTALLATION MEETS ALL APPLICABLE CODE REQUIREMENTS.
2. ILLUSTRATION SHOWN IS FOR GENERAL REPRESENTATION ONLY. ACTUAL PRODUCT WILL VARY DEPENDENT UPON APPLICATION.
3. OVERALL DIMENSIONS: 97.7 L X 44.0 W X 78.0 T.
4. B AND G STANDS FOR PUMP VENDOR "BELL AND GOSSETT".

INFORMATION SUBJECT TO CHANGE

DIMENSIONS ARE IN INCHES. DATE DRAWN: 2017/09/15  THIRD ANGLE PROJECTION	<b>HUSSmann®</b> PUMP STATION-450 GPM B AND G
	DOC PD-000000027 REV B

SHEET 1 OF 3

***MINIMUM CLEARANCE REQUIREMENTS:***

ACTUAL CLEARANCE REQUIREMENTS ARE DEPENDENT UPON AUTHORITY HAVING JURISDICTION, AND MAY EXCEED DIMENSIONS SHOWN.

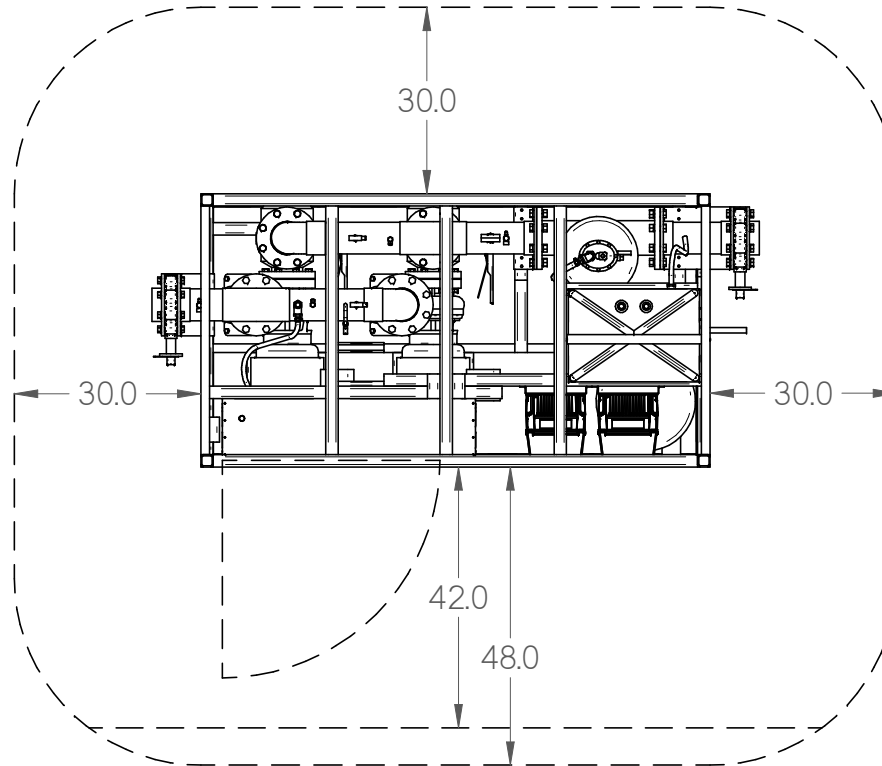

42" CLEARANCE BETWEEN CONTROL PANEL & ANY WALL.

48" CLEARANCE BETWEEN CONTROL PANEL & ANY LIVE PANEL.

**NOTES:**

1. IT IS THE RESPONSIBILITY OF THE INSTALLING CONTRACTOR TO ENSURE THAT THE FINAL EQUIPMENT INSTALLATION MEETS ALL APPLICABLE CODE REQUIREMENTS.
2. ILLUSTRATION SHOWN IS FOR GENERAL REPRESENTATION ONLY. ACTUAL PRODUCT WILL VARY DEPENDENT UPON APPLICATION.
3. OVERALL DIMENSIONS: 97.7 L X 44.0 W X 78.0 T.
4. B AND G STANDS FOR PUMP VENDOR "BELL AND GOSSETT".

DIMENSIONS ARE IN INCHES.  
DATE DRAWN: 2017/09/15



THIRD  
ANGLE  
PROJECTION

**HUSSmann®**

PUMP STATION-450  
GPM B AND G

INFORMATION SUBJECT TO CHANGE

SHEET 3 OF 3

DOC PD-000000027 REV B

SWIN10 SUBMITTAL SHEET SIZE D

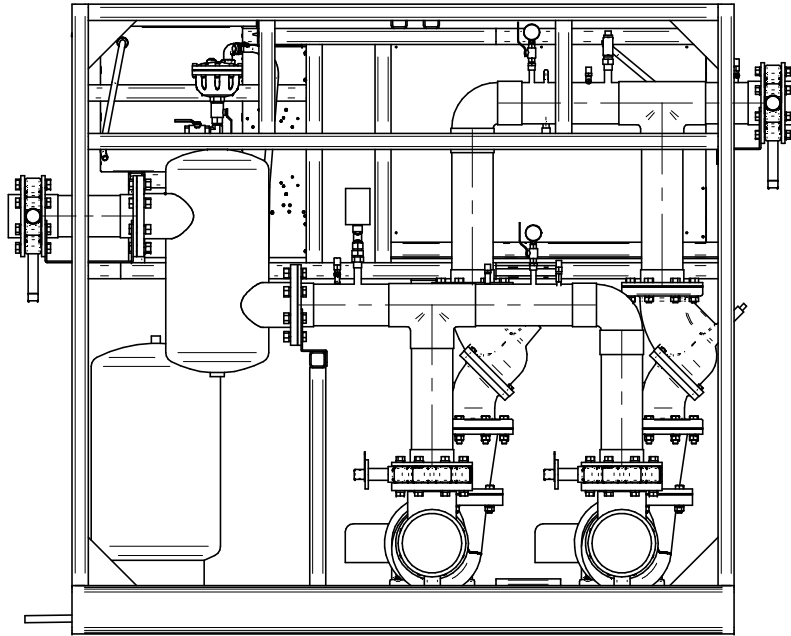

BACK VIEW

NOTES:

1. IT IS THE RESPONSIBILITY OF THE INSTALLING CONTRACTOR TO ENSURE THAT THE FINAL EQUIPMENT INSTALLATION MEETS ALL APPLICABLE CODE REQUIREMENTS.
2. ILLUSTRATION SHOWN IS FOR GENERAL REPRESENTATION ONLY. ACTUAL PRODUCT WILL VARY DEPENDENT UPON APPLICATION.
3. OVERALL DIMENSIONS: 97.7 L X 44.0 W X 78.0 T.
4. B AND G STANDS FOR PUMP VENDOR "BELL AND GOSSETT".

 THIRD ANGLE PROJECTION	<b>HUSSmann®</b> PUMP STATION-450 GPM B AND G
	DIMENSIONS ARE IN INCHES. DATE DRAWN: 2017/09/15
INFORMATION SUBJECT TO CHANGE	DOC PD-000000027 REV B
SHEET 2 OF 3	SWIN10 SUBMITTAL SHEET SIZE D