

TOP VIEW AND CLEARANCE REQUIREMENTS ON SHEET 3

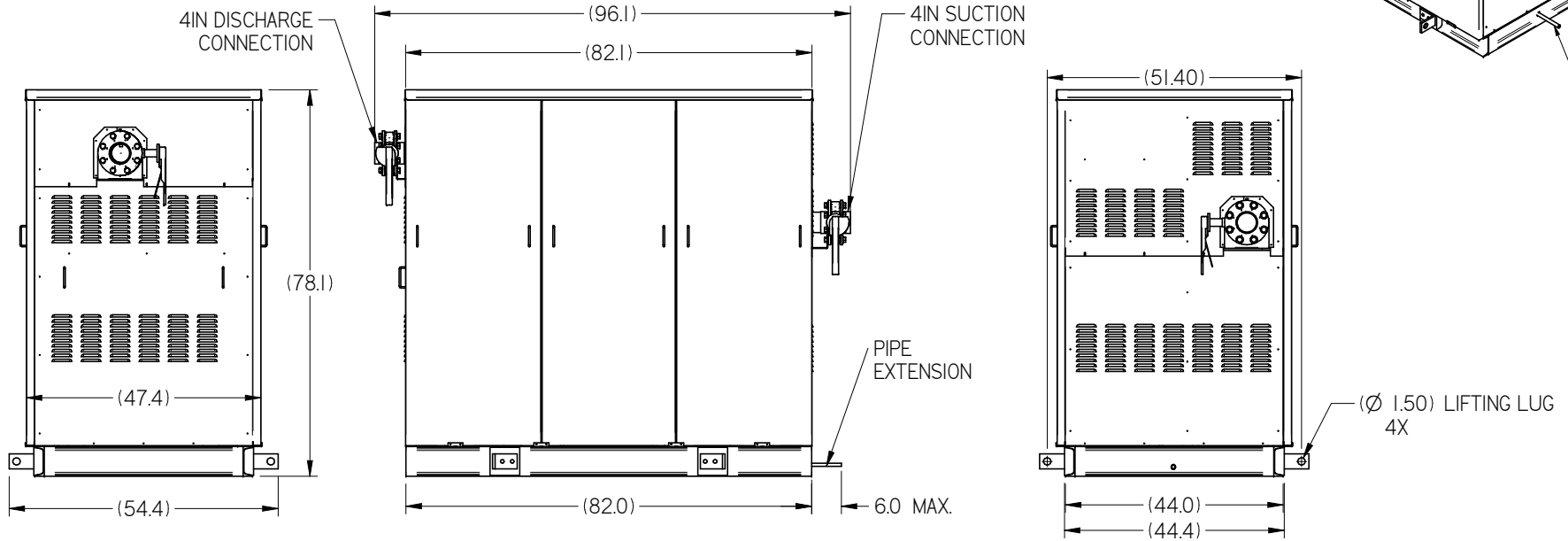
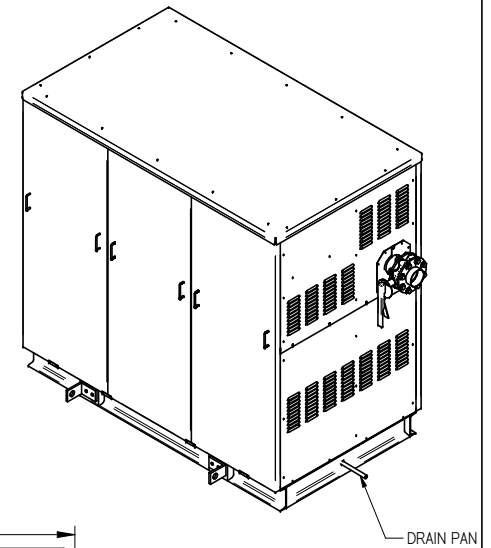

- NOTES:
1. IT IS THE RESPONSIBILITY OF THE INSTALLER TO ENSURE THAT THE FINAL EQUIPMENT INSTALLATION MEETS ALL APPLICABLE CODE REQUIREMENTS.
 2. ILLUSTRATION SHOWN IS FOR GENERAL REPRESENTATION ONLY. ACTUAL PRODUCT WILL VARY DEPENDENT UPON APPLICATION.
 3. OVERALL DIMENSIONS: 96.1 L X 54.4 W X 78.1 H.

DIMENSIONS ARE IN INCHES. DATE DRAWN: 2017/09/14	THIRD ANGLE PROJECTION	HUSSmann®	
		PUMP STATION-4IN OUTDOOR FRAME AND SKINS	
SHEET 1 OF 3		DOC PD-000000089	REV B

INFORMATION SUBJECT TO CHANGE

SHEET SUBMITTAL SHEET SIZE D

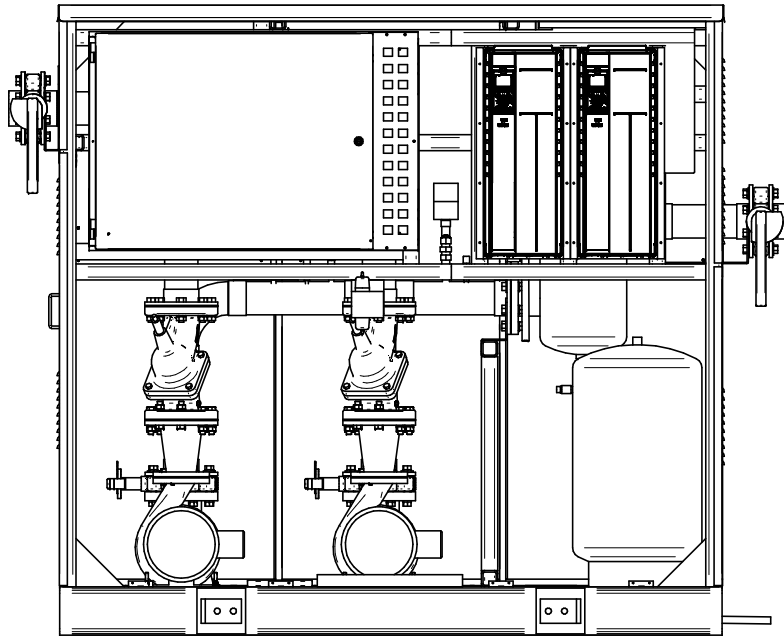

FRONT VIEW WITHOUT DOORS
 ARMSTRONG PUMPS CONFIGURATION SHOWN,
 B & G IS DIFFERENT

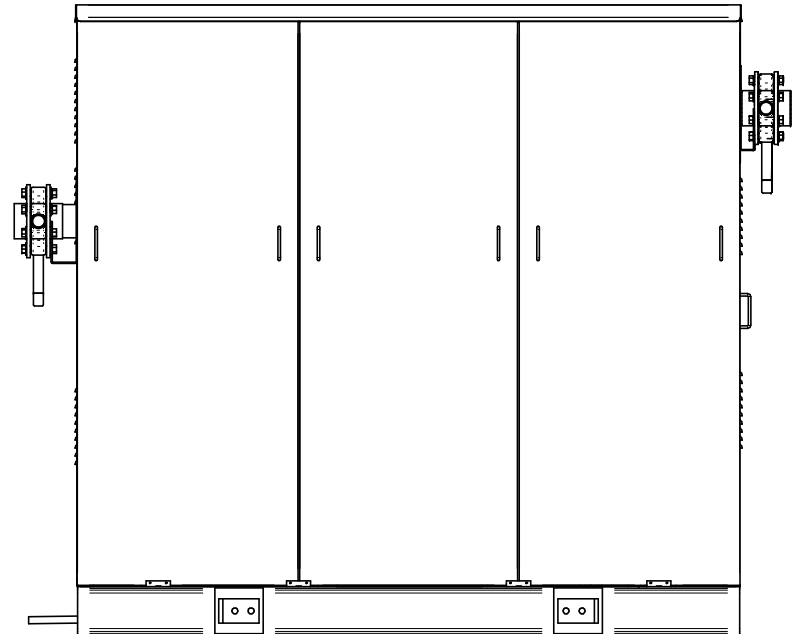

BACK VIEW

- NOTES:
1. IT IS THE RESPONSIBILITY OF THE INSTALLER TO ENSURE THAT THE FINAL EQUIPMENT INSTALLATION MEETS ALL APPLICABLE CODE REQUIREMENTS.
 2. ILLUSTRATION SHOWN IS FOR GENERAL REPRESENTATION ONLY. ACTUAL PRODUCT WILL VARY DEPENDENT UPON APPLICATION.
 3. OVERALL DIMENSIONS: 96.1 L X 54.4 W X 78.1 H.

DIMENSIONS ARE IN INCHES. DATE DRAWN: 2017/09/14  THIRD ANGLE PROJECTION	HUSSmann®	
	PUMP STATION-4IN OUTDOOR FRAME AND SKINS	
SHEET 2 OF 3	DOC PD-000000089	REV B

SHEET SUBMITTAL SHEET SIZE D

MINIMUM CLEARANCE REQUIREMENTS:

ACTUAL CLEARANCE REQUIREMENTS ARE DEPENDENT UPON AUTHORITY HAVING JURISDICTION, AND MAY EXCEED DIMENSIONS SHOWN.

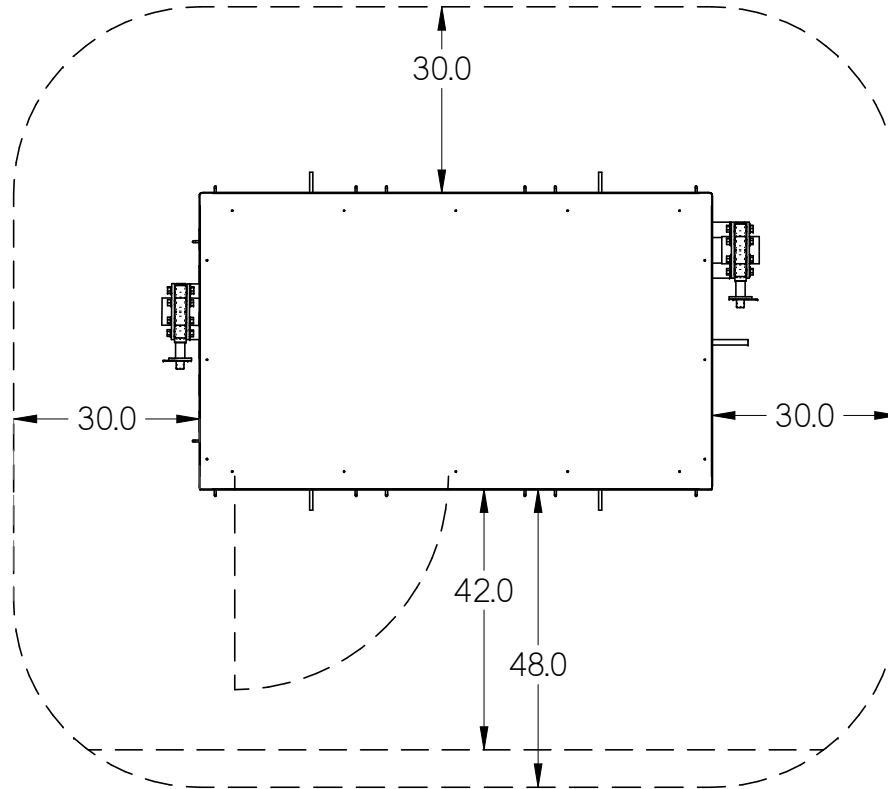

42" CLEARANCE BETWEEN CONTROL PANEL & ANY WALL.

48" CLEARANCE BETWEEN CONTROL PANEL & ANY LIVE PANEL.

- NOTES:
1. IT IS THE RESPONSIBILITY OF THE INSTALLER TO ENSURE THAT THE FINAL EQUIPMENT INSTALLATION MEETS ALL APPLICABLE CODE REQUIREMENTS.
 2. ILLUSTRATION SHOWN IS FOR GENERAL REPRESENTATION ONLY. ACTUAL PRODUCT WILL VARY DEPENDENT UPON APPLICATION.
 3. OVERALL DIMENSIONS: 96.1 L X 54.4 W X 78.1 H.

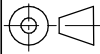
DIMENSIONS ARE IN INCHES. DATE DRAWN: 2017/09/14	HUSSmann®
 THIRD ANGLE PROJECTION	PUMP STATION-4IN OUTDOOR FRAME AND SKINS
SHEET 3 OF 3	DOC PD-000000089 REV B

SWIN10 SUBMITTAL SHEET SIZE D