

HUSSMANN®



Intertek



Intertek

Q3SS6S Medium Temperature Self Contained

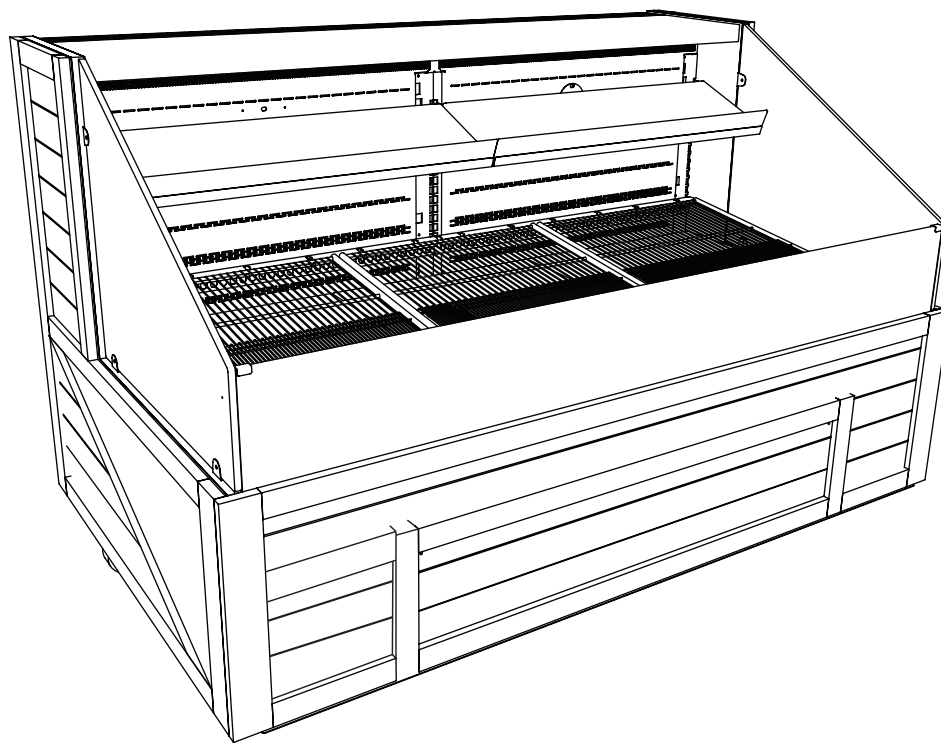

Installation & Operation Manual

IMPORTANT
Keep in store for
future reference!

P/N 0553787_G
June 2020

ATTENTION

Merchandiser must operate for 24 hours
before loading product!

Regularly check merchandiser temperatures.

Do not break the cold chain. Keep products
in cooler before loading into merchandiser.

These merchandisers are designed
for pre-chilled products only.



IMPORTANT
KEEP IN STORE FOR FUTURE REFERENCE
Quality that sets industry standards!

12999 St. Charles Rock Road • Bridgeton, MO 63044-2483

U.S. & Canada 1-800-922-1919 • Mexico 1-800-890-2900

www.hussmann.com

© 2020 Hussmann Corporation

ANSI Z535.5 DEFINITIONS iv

INSTALLATION

NSF Listing 1-1
Federal / State Regulation 1-1
Husmann Product Control 1-1
Shipping Damage 1-1
Location 1-1
Self Contained (Location) 1-2
Unloading 1-3
Exterior Loading 1-3
Shipping Skid 1-3
Merchandiser Leveling 1-4
Serial Plate Location 1-4
Refrigeration Unit Access 1-4
Self-Contained Refrigeration Equipment
Start Up Check List 1-5

ELECTRICAL / REFRIGERATION

Merchandiser Electrical Data 2-1
Field Wiring 2-1
Electrical Connections 2-1
Electrical Outlet 2-1
Refrigeration (Self Contained Models) .. 2-1
Waste Outlet and Water Seal 2-2

START UP / OPERATION

Controller Operation 3-1
Data 3-4
Controls and Adjustments 3-6
Start-Up 3-7
TEV Adjustment 3-7
Load Limits 3-8
Stocking 3-8
Thermometer 3-8

MAINTENANCE

Care and Cleaning 4-1
Removing Scratches from Bumper 4-2
Cleaning Under Fan Plenum 4-2
Cleaning Discharge Air Louvers 4-2
Cleaning Stainless Steel Surfaces 4-3
Cleaning Coils 4-3
Cleaning Evaporation Pan 4-4
Self-Contained Refrigeration Equipment
Maintenance Check List 4-5

SERVICE

Replacing Fan Motors and Blades 5-1
Replacement Parts List 5-2

APPENDIX

Plan View A-1
Cross Section A-2
Refrigeration Data A-3
Defrost Data A-3
Physical Data A-3
Electrical Data A-4
Product Data A-4
Shipping Weights and Amps A-5
Wiring Diagram A-6

WARRANTY

REVISION HISTORY

REVISION G

Page 3-6 - Controls and Adjustments; Page 5-2 - Parts
List Page A-3 to A-5 - Data

ORIGINAL ISSUE — AUGUST 2015

ANSI Z535.5 DEFINITIONS



• **DANGER** – Indicate[s] a hazardous situation which, if not avoided, will result in death or serious injury.



• **WARNING** – Indicate[s] a hazardous situation which, if not avoided, could result in death or serious injury.



• **CAUTION** – Indicate[s] a hazardous situation which, if not avoided, could result in minor or moderate injury.

• **NOTICE** – *Not related to personal injury* – Indicates[s] situations, which if not avoided, could result in damage to equipment.

INSTALLATION

NSF LISTING

These merchandisers are manufactured to meet ANSI / UL 471 standard requirements for safety. Proper installation is required to maintain this listing. Near the serial plate, each case carries a label identifying the type of conditions for which the merchandiser was tested.

ANSI/NSF-7 Type I – Display Refrigerator / Freezer Intended for 75°F / 55% RH Ambient Application

ANSI/NSF-7 Type II – Display Refrigerator / Freezer Intended for 80°F / 55% RH Ambient Application

ANSI/NSF-7 – Display Refrigerator Intended for Bulk Produce

FEDERAL / STATE REGULATION

These merchandisers, at the time they are manufactured, meet all federal and state / provincial regulations.

HUSSMANN PRODUCT CONTROL

The serial number and shipping date of all equipment is recorded in Hussmann's files for warranty and replacement part purposes. All correspondence pertaining to warranty or parts ordering must include the serial number of each piece of equipment involved. This is to ensure the customer is provided with the correct parts.

SHIPPING DAMAGE

All equipment should be thoroughly examined for shipping damage before and during unloading. This equipment has been carefully inspected at our factory. Any claim for loss or damage must be made to the carrier. The carrier will provide any necessary inspection reports and/or claim forms.

Apparent Loss or Damage

If there is an obvious loss or damage, it must be noted on the freight bill or express receipt and signed by the carrier's agent; otherwise, carrier may refuse claim.

Concealed Loss or Damage

When loss or damage is not apparent until after equipment is uncrated, retain all packing materials and submit a written response to the carrier for inspection within 15 days.

LOCATION

These merchandisers are designed for displaying products in air conditioned stores where temperature is maintained at or below the ANSI / NSF-7 specified level and relative humidity is maintained at or below 55%.

Recommended operating ambient temperature is between 65°F (18°C) to 75°F (23.9°C). Maximum relative humidity is 55%.

Placing refrigerated merchandisers in direct sunlight, near hot tables or near other heat sources could impair their efficiency. Like other merchandisers, these merchandisers are sensitive to air disturbances. Air currents passing around merchandisers will seriously impair their operation. Do NOT allow air conditioning, electric fans, open doors or windows, etc. to create air currents around the merchandiser.

1-2 INSTALLATION

SELF CONTAINED (LOCATION)

Product should always be maintained at proper temperature. This means that from the time the product is received, through storage, preparation and display, the temperature of the product must be controlled to maximize the life of the product.

BE SURE TO POSITION SELF CONTAINED MERCHANDISERS PROPERLY.

SELF CONTAINED models have vented base panels to allow air circulation through the condensing unit. Allow for a minimum 4 in. clearance from walls, merchandisers, and any other large objects near the merchandiser's vented base panels (for self contained models). Blocking or restricting air flow will adversely affect performance and may damage the refrigeration system.

For California Businesses:

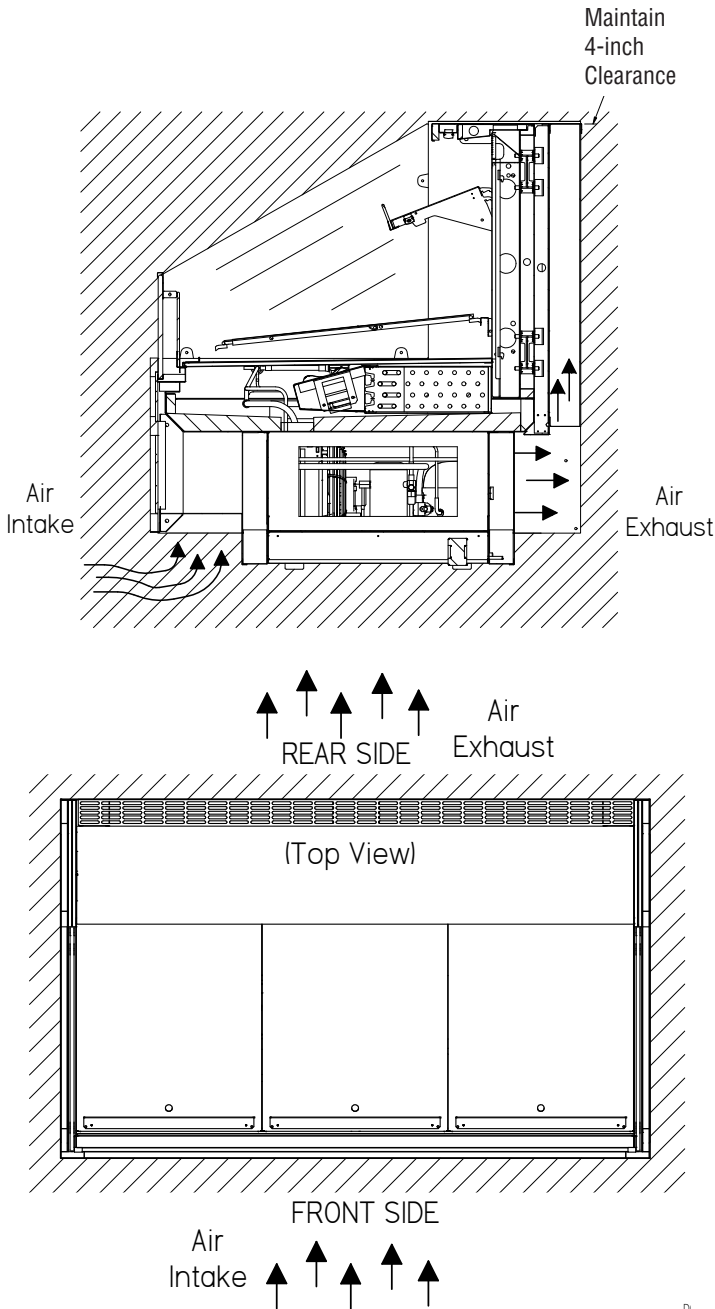

⚠ WARNING

This product may contain chemicals known to the State of California to cause cancer, birth defects, or other reproductive harm.

This warning is the result of the California State law known as the California Safe Drinking Water and Toxic Enforcement Act of 1986, which is commonly referred to as "Proposition 65."

This warning does not mean that Hussmann products will cause cancer or reproductive harm, or is in violation of any product-safety standards or requirements. As clarified by the California State government, Proposition 65 can be considered more of a 'right to know' law than a pure product safety law. When used as designed, Hussmann believes that our products are not harmful. We provide the Proposition 65 warning to stay in compliance with California State law. It is your responsibility to provide accurate Proposition 65 warning labels to your customers when necessary. For more information on Proposition 65, please visit the California State government website.

UNLOADING

Unloading from Trailer:

Lever Bar (also known as a Mule, Johnson Bar, J-bar, Lever Dolly, or Pry Lever)

Move the merchandiser as close as possible to its permanent location and remove all packaging. Check for damage before discarding packaging. Remove all separately packed accessories such as kits and shelves.

Improper handling may cause damage to the merchandiser when unloading. To avoid damage:

1. Do not drag the merchandiser out of the trailer. Use a Johnson bar (mule).
2. Use a forklift or dolly to remove the merchandiser from the trailer.



WARNING

Do NOT stand or walk on top of merchandiser. Do not store items or flammable materials atop the unit.

EXTERIOR LOADING

Do NOT walk on top of merchandisers or damage to the merchandisers and serious personal injury could occur.

MERCHANDISERS ARE NOT STRUCTURALLY DESIGNED TO SUPPORT EXTERNAL LOADING such as the weight of a person. Do not place heavy objects on the merchandiser.

SHIPPING SKID

Each merchandiser is shipped on a skid to protect the merchandiser's base, and to make positioning the case easier.

Remove the top of the crate and detach walls from each other. Lift crate from the skid. Unscrew the case from the skid. The fixture can now be lifted off the crate skid. **Lift only at base of skid!** Remove any braces and/or skids attached (blanket wrapped merchandiser may have skids).

DO NOT LAY MERCHANDISER OVER ON THE FLOOR TO REMOVE SKID.

Once the skid is removed, the merchandiser must be lifted —NOT PUSHED— to reposition. To remove the skid, remove screws attaching skid to the merchandiser.

Check floor where cases are to be set to see if it is a level area. Determine the highest part of the floor.



WARNING

Do NOT remove shipping crate until the merchandiser is positioned for installation.

1-4 INSTALLATION

MERCHANDISER LEVELING

BE SURE TO POSITION MERCHANDISERS PROPERLY. Level the merchandiser by all four corners. Merchandiser(s) must be installed level to ensure proper operation of the refrigeration system, and to ensure proper drainage of defrost water.

SERIAL PLATE LOCATION

The serial plate is located on the inside of the merchandiser's display area as shown below.

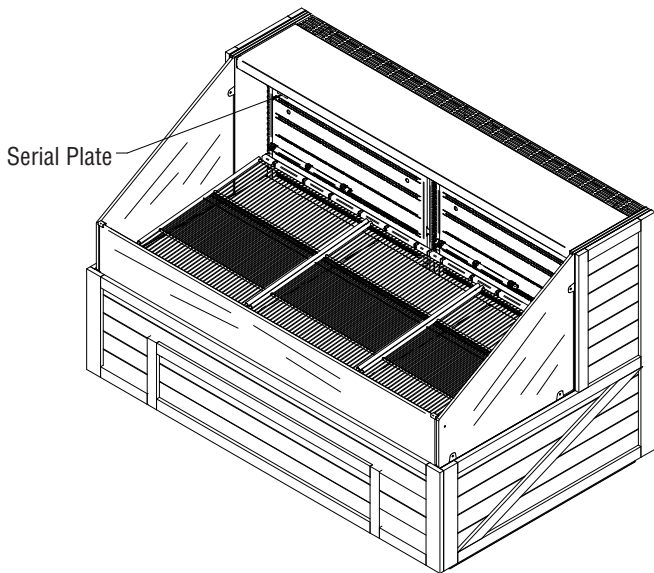

REFRIGERATION UNIT ACCESS

The rear front panel may be removed by lifting the panel straight upward and over the tabs on which it is hanging. Screws will have to be removed from either end of the panel. The panel is installed by reversing the above procedure. Ensure lower front panel is flat against the floor when installed to prevent air circulation problems.

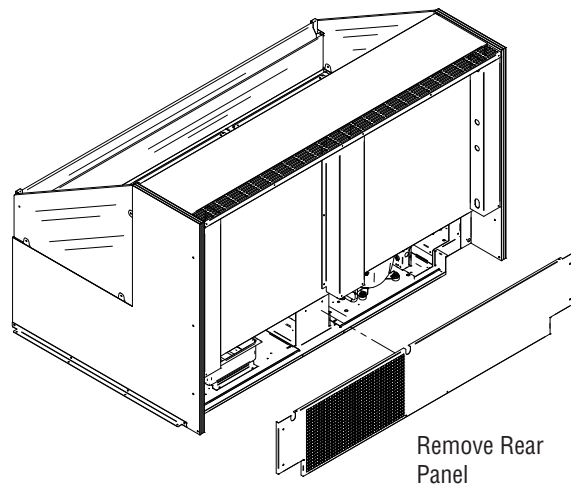

Hussmann Self-Contained Refrigeration Equipment Start Up Check List

Please note that failure to follow this start-up document may void your factory warranty

Step	Startup Activity	Check
1	Locate, read and maintain install/operation manual in a safe place for future reference.	<input type="checkbox"/>
2	Examine unit. Confirm there is NO damage or concealed damage.	<input type="checkbox"/>
3	Level the unit, side to side and front to rear.	<input type="checkbox"/>
4	Remove all shipping brackets/compressor straps/bolts etc.	<input type="checkbox"/>
5	Unit must be run on a dedicated electrical circuit without the use of an extension cord.	<input type="checkbox"/>
6	Ensure that the proper electrical requirements for the equipment are supplied.	<input type="checkbox"/>
7	Verify field electrical connections are tight.	<input type="checkbox"/>
8	Verify all electrical wiring is secured and clear of any sharp edges or hot lines.	<input type="checkbox"/>
9	Verify the condensate drain line is properly trapped and pitched.	<input type="checkbox"/>
10	Verify all required clearances on the sides and back of unit.	<input type="checkbox"/>
11	Verify there are no air disturbances external to the unit. Heat and air registers, fans, and doors etc.	<input type="checkbox"/>
Advise owner/operator that merchandiser must operate at temperature for 24 hrs prior to loading with product.		

Form HSCW01 Rev. 30MAY12 P/N 0525209_B

LEGAL DISCLAIMER:

Hussmann shall not be liable for any repair or replacements made without the written consent of Hussmann, or when the product is installed or operated in a manner contrary to the printed instructions covering installation and service which accompanied such product.

1-6 INSTALLATION

NOTES:

ELECTRICAL / REFRIGERATION

MERCHANDISER ELECTRICAL DATA

Refer to the technical data sheets and merchandiser serial plate for electrical information.

FIELD WIRING

Field wiring must be sized for component amperes stamped on the serial plate. Actual ampere draw may be less than specified.

**ALWAYS CHECK THE SERIAL PLATE FOR
COMPONENT AMPERES**

ELECTRICAL CONNECTIONS

All wiring must be in compliance with NEC and local codes.

ELECTRICAL OUTLET

Before the merchandiser is connected to any wall circuit, use a voltmeter to check that the outlet is at 100% of the rated voltage. The wall circuit must be dedicated for the merchandiser. Failure to do so voids the warranty. Do not use an extension cord. Never plug in more than one merchandiser per electrical circuit.

- Always use a dedicated circuit with the amperage stated on the unit.
- Plug into an outlet designed for the plug.
- Do not overload the circuit
- Do not use long or thin extension cords. Never use adapters.
- If in doubt, call an electrician.

Self-contained models have factory-installed power cords attached at the electrical box.

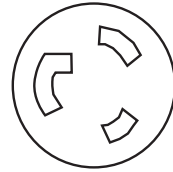

NEMA L6-20R
Receptacle

REFRIGERATION (Self Contained Models)

Each self contained model is equipped with its own condensing unit and control panel located beneath the display area. The correct type of refrigerant will be stamped on each merchandiser's serial plate. The merchandiser refrigeration piping is leak tested. The unit is charged with refrigerant, and shipped from the factory with all service valves open.

WATER OUTLET AND WATER SEAL

The condensate water outlet is located in the center of the merchandiser. The outlet has a factory installed, external water seal.

For self contained models, this water seal drains into the condensate evaporator pan located beneath the merchandiser.

NOTE: All lower base panels must be in place when the refrigerator is operating. If not, air-flow from the condenser will be directed over the evaporator pan and defrost water in the pan may overflow.

**WARNING**

Product will be degraded and may spoil if allowed to sit in a non-refrigerated area.

**WARNING**

Refrigeration lines are under pressure. Refrigerant must be recovered before attempting any connection or repair.

**WARNING**

— LOCK OUT / TAG OUT —

To avoid serious injury or death from electrical shock, always disconnect the electrical power at the main disconnect when servicing or replacing any electrical component. This includes, but is not limited to, such items as doors, lights, fans, heaters, and thermostats.

**WARNING**

**Merchandiser must be grounded.
Do not remove the power supply cord ground.**

**CAUTION**

Risk of Electric Shock. If cord or plug becomes damaged, replace only with a cord and plug of the same type.

START UP / OPERATION

Operation

Display

The values will be shown with three digits, and with a setting you can determine whether the temperature are to be shown in °C or in °F.

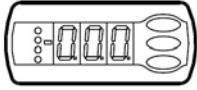

Light-emitting diodes (LED) on front panel

HACCP = HACCP function is active

The other LED's on the front panel will light up when the belonging relay is activated.

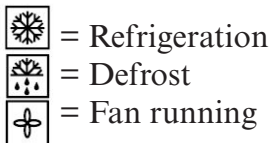

The light-emitting diodes will flash when there is an alarm.

In this situation you can download the error code to the display and cancel/sign for the alarm by giving the top knob a brief push.

The Buttons

When you want to change a setting, the upper and the lower buttons will give you a higher or lower value depending on the button you are pushing. But before you change the value, you must have access to the menu. You obtain this by pushing the upper button for a couple of seconds - you will then enter the column with parameter codes. Find the parameter code you want to change and push the middle buttons until value for the parameter is shown. When you have changed the value, save the new value by once more pushing the middle button.

Reprinted with permission from the controller manufacturer.

Examples

Set menu

1. Push the upper button until a parameter r01 is shown
2. Push the upper or the lower button and find that parameter you want to change
3. Push the middle button until the parameter value is shown
4. Push the upper or the lower button and select the new value
5. Push the middle button again to freeze the value.

Cutout alarm relay / receipt alarm/see alarm code

- Push short the upper button
- If there are several alarm codes they are found in a rolling stack. Push the uppermost or lowermost button to scan the rolling stack.

Set temperature

1. Push the middle button until the temperature value is shown
2. Push the upper or the lower button and select the new value
3. Push the middle button again to conclude the setting.

Reading the temperature at defrost sensor

- Push short the lower button

Manual start or stop of a defrost

- Push the lower button for four seconds. (Though not for application 4).

Defrost

During defrost a -d- is shown in the display. This view will continue up till 15 min. after the cooling has resumed.

However the view of -d- will be discontinued if:
 -The temperature is suitable within the 15 minutes
 -The regulation is stopped with “Main Switch”
 -A high temperature alarm appears

Alarms

The controller can give alarm in different situations. When there is an alarm all the light-emitting diodes (LED) will flash on the controller front panel, and the alarm relay will cut in.

Upper alarm limit

Here you set when the alarm for high temperature is to start. The limit value is set in °C (absolute value). The limit value will be raised during night operation. The value is the same as the one set for night setback, but will only be raised if the value is positive.

The limit value will also be raised in connection with reference displacement r39.

Lower alarm limit

Here you set when the alarm for low temperature is to start. The limit value is set in °C (absolute value). The limit value will also be raised in connection with reference displacement r39.

Signal to the alarm thermostat

Here you have to define the ratio between the sensors which the alarm thermostat has to use. S3, S4 or a combination of the two. With setting 0% only S3 is used. With 100% only S4 is used.

Connections

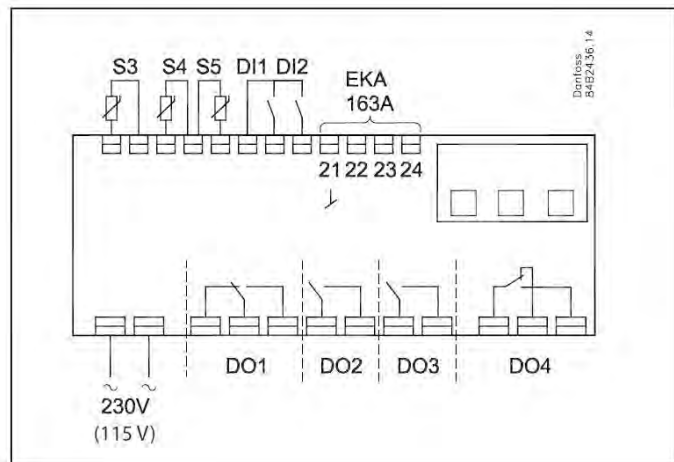

Power supply

230 V a.c.

Sensors

S3 and S4 are thermostat sensors. A setting determines whether S3 or S4 or both of them are to be used. S5 is a defrost sensor and is used if defrost has to be stopped based on temperature.

Digital On/Off signals

A cut-in input will activate a function. The possible functions are described in menus o02 and o37.

External display

Connection of display type EKA 163A (EKA 164A).

Relays

The general uses are mentioned here. See also page 6 where the different applications are shown.

- DO1: Refrigeration. The relay will cut in when the controller demands refrigeration
- DO2: Defrost. The relay will cut in when defrost is in progress

DO3: For either fans or refrigeration 2

Fans: The relay will cut in when the fans have to operate
Refrigeration 2: The relay will cut in when refrigeration step 2 has to be cut in

DO4: For either alarm, rail heat, light or hotgas defrost

Alarm: Cf. diagram. The relay is cut in during normal operation and cuts out in alarm situations and when the controller is dead (de-energised)

Rail heat: The relay cuts in when rail heat is to operate

Light: The relay cuts in when the light has to be switched on
Hotgas defrost: See diagram. The relay will cut out when defrost has to be done

Data communication

The controller is available in several versions where data communication can be carried out with one of the following systems: MOD-bus or LON-RS485.

If data communication is used, it is important that the installation of the data communication cable is performed correctly.

See separate literature No. RC8AC...

Electric noise

Cables for sensors, DI inputs and data communication **must** be kept separate from other electric cables:

- Use separate cable trays
- Keep a distance between cables of at least 10 cm
- Long cables at the DI input should be avoided



WARNING

Product will be degraded and may spoil if allowed to sit in a non-refrigerated area.

Data

Supply voltage	230 V a.c. +10/-15 %, 2.5 VA, 50/60 Hz		
Sensors 3 pcs off either	Pt 1000 or PTC 1000 or NTC-M2020 (5000 ohm / 25°C)		
Accuracy	Measuring range	-60 to +99°C	
	Controller	±1 K below -35°C ±0.5 K between -35 to +25°C ±1 K above +25°C	
	Pt 1000 sensor	±0.3 K at 0°C ±0.005 K per grad	
Display	LED, 3-digits		
External display	EKA 163A		
Digital inputs	Signal from contact functions Requirements to contacts: Gold plating Cable length must be max. 15 m Use auxiliary relays when the cable is longer		
Electrical connection cable	Max. 1,5 mm ² multi-core cable		
Relays*		CE (250 V a.c.)	UL *** (240 V a.c.)
	DO1. Refrigeration	10 (6) A	10 A Resistive 5FLA, 30LRA
	DO2. Defrost	10 (6) A	10 A Resistive 5FLA, 30LRA
	DO3. Fan	6 (3) A	6 A Resistive 3FLA, 18LRA 131 VA Pilot duty
	DO4. Alarm	4 (1) A Min. 100 mA**	4 A Resistive 131 VA Pilot duty
Environments	0 to +55°C, During operations -40 to +70°C, During transport 20 - 80% Rh, not condensed No shock influence / vibrations		
Density	IP 65 from front. Buttons and packing are imbedded in the front.		
Escapement reserve for the clock	4 hours		
Approvals	EU Low Voltage Directive and EMC demands re CE-marking complied with LVD tested acc. EN 60730-1 and EN 60730-2-9, A1, A2 EMC tested acc. EN61000-6-3 and EN 61000-6-2		

* DO1 and DO2 are 16 A relays. DO3 and DO4 are 8 A relays. Max. load must be kept.
 ** Gold plating ensures make function with small contact loads
 *** UL-approval based on 30000 couplings

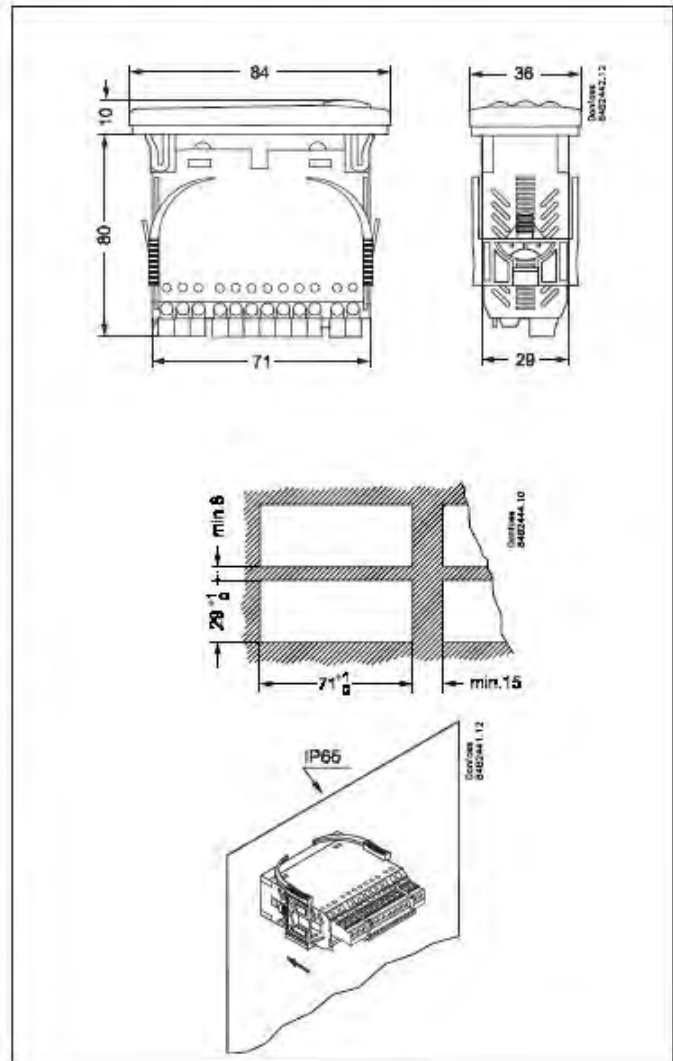

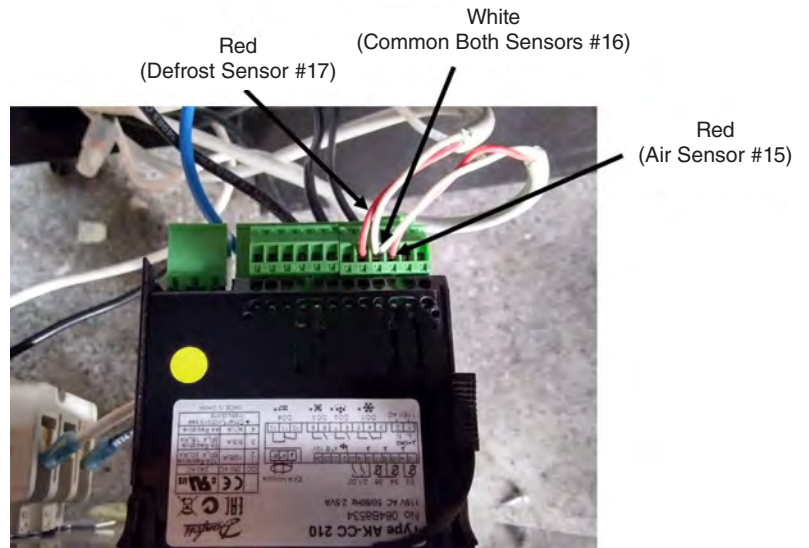
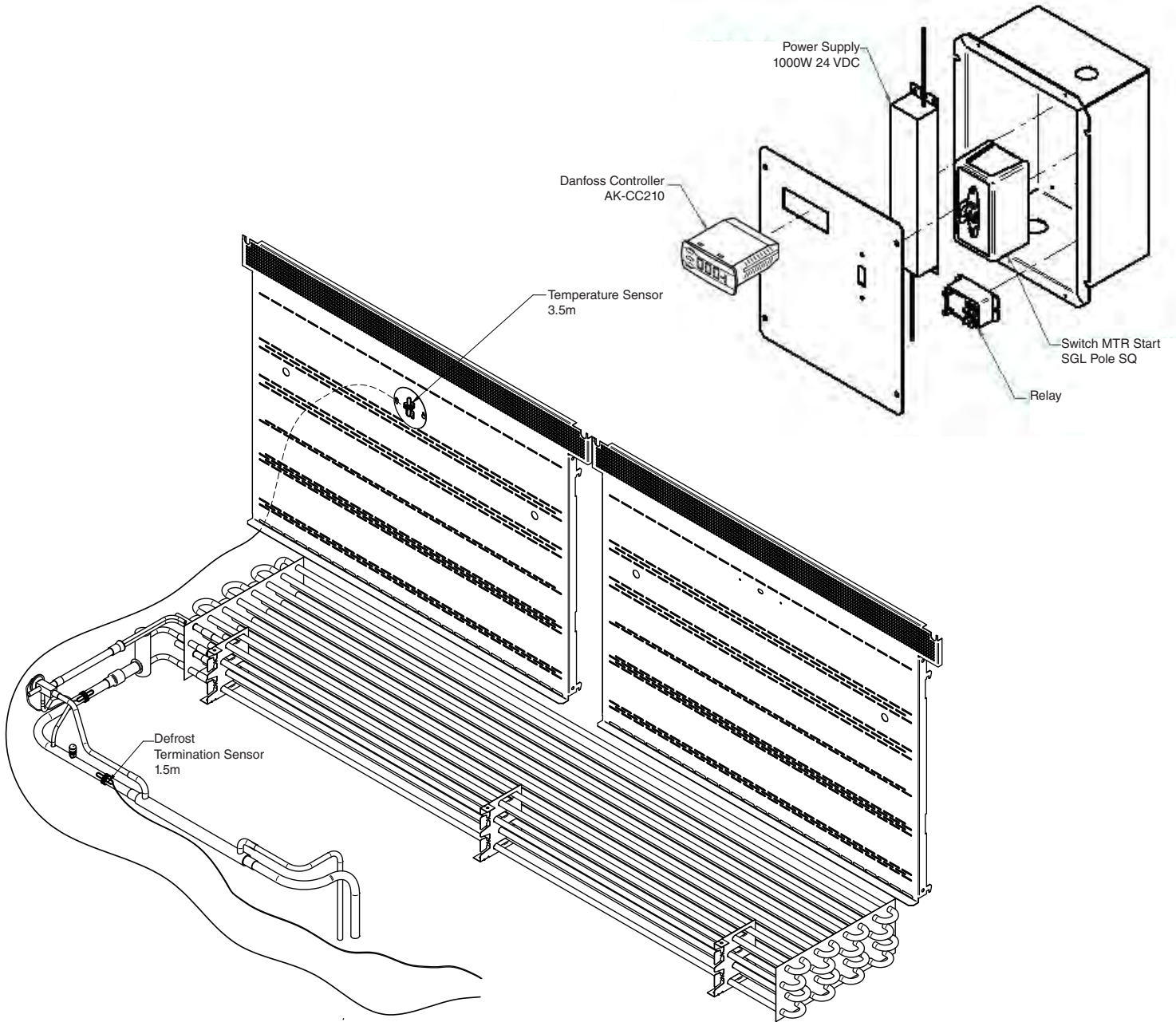

CONTROLS and ADJUSTMENTS						
Refrigeration Controls			Defrost Controls			
Model	Product Application	Discharge Air Temperature	Defrost Frequency (per day)	Type of Defrost	Temp. Termination	Failsafe Time (Minutes)
Q3SS6S Self Contained	Medium Temp. (Dairy, Deli)	21° F	4	Off Time	48° F	50

1. Controller controls refrigeration temperature. This is factory installed in the control panel. Adjust this control knob to maintain the discharge air temperature shown. Measure discharge air temperatures at the center of the discharge louver.

Defrosts are time initiated and temperature terminated for self contained. The defrost setting is factory set as shown above.

To ensure a thorough defrost, defrost must be terminated by the temperature termination setting — not by time.

START UP

Follow the start up procedures as detailed in Section 3 of this manual.

Each self contained merchandiser has its own evaporator coil and a pre-set thermostatic expansion valve (TEV). The TEV has been factory set at design conditions to provide the recommended performance.

Low Pressure
Cut In: 30 psi
Cut out: 10 psi

High Pressure
Cut Out: 325 psi

TEV ADJUSTMENT

Expansion valves may be adjusted to fully feed the evaporator. Before attempting to adjust valves, make sure the evaporator is clear or only lightly covered with frost, and the merchandiser is within 10°F of its expected operating temperature.

Adjust the valve as Follows:

- a. Attach a probe to the suction line near the expansion valve bulb.
- b. Obtain a pressure reading from the factory installed Schraeder valve. Convert the pressure reading to a saturated temperature for the refrigerant.

Temperature (b) minus Temperature (a) is the superheat. The valve should be adjusted so that the greatest difference between the two temperatures is 3°F to 5° F.

Make adjustments of no more than 1/2 turn of the valve stem at a time and wait for at least 15 minutes before rechecking the probe temperature and making further adjustments.

3-8 START UP / OPERATION

LOAD LIMITS

Each merchandiser has a load limit decal. Shelf life of perishables will be short if load limit is violated.

AT NO TIME SHOULD MERCHANDISERS BE STOCKED BEYOND THE LOAD LIMITS INDICATED.



STOCKING

Product should NOT be placed inside the merchandisers until merchandisers are at proper operating temperature.

Allow merchandiser 24 hours to operate before loading product.

Proper rotation of product during stocking is necessary to prevent product loss. Always bring the oldest product to the top and set the newest to the bottom.

AIR DISCHARGE AND RETURN FLUES MUST REMAIN OPEN AND FREE OF OBSTRUCTION AT ALL TIMES to provide proper refrigeration and air curtain performance. Do not allow product, packages, signs, etc. to block these grilles. Do not use non-approved shelving, baskets, display racks, or any accessory that could hamper air curtain performance.

Do not allow product to be placed outside of the designated load limits in the illustration.

THERMOMETER

Q3SS6S models have a solar thermometer. The thermometer is located at the top interior of the merchandiser.

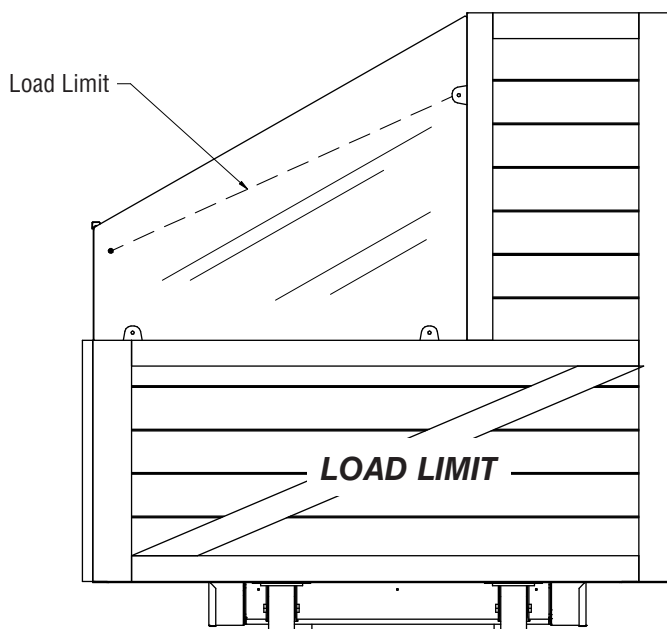

MAINTENANCE

CARE AND CLEANING

Long life and satisfactory performance of any equipment is dependent upon the care it receives. To ensure long life, proper sanitation and minimum maintenance costs, these merchandisers should be thoroughly cleaned, all debris removed and the interiors washed down, weekly.

Exterior Surfaces

The exterior surfaces must be cleaned with a mild detergent and warm water to protect and maintain their attractive finish. **NEVER USE ABRASIVE CLEANSERS OR SCOURING PADS.**

Interior Surfaces

The interior surfaces may be cleaned with most domestic detergents, ammonia based cleaners and sanitizing solutions with no harm to the surface. Self contained models empty into a limited capacity evaporation pan, which will overflow if excess water is used in cleaning.

Do NOT Use:

- Abrasive cleansers and scouring pads, as these will mar the finish.
- Coarse paper towels on coated glass.
- Ammonia-based cleaners on acrylic parts.
- Solvent, oil or acidic based cleaners on any interior surfaces.
- Do not use high pressure water hoses.

Do:

- Remove the product and all loose debris to avoid clogging the waste outlet.
- Store product in a refrigerated area such as a cooler. Remove only as much product as can be taken to the cooler in a timely manner.
- Disconnect electrical power before cleaning.**
- Thoroughly clean all surfaces with soap and hot water. **DO NOT USE STEAM OR HIGH WATER PRESSURE HOSES TO WASH THE INTERIOR. THESE WILL DESTROY THE MERCHANDISERS' SEALING CAUSING LEAKS AND POOR PERFORMANCE.**
- Take care to minimize direct contact between fan motors and cleaning or rinse water.
- Do NOT flood merchandiser with water. **NEVER INTRODUCE WATER FASTER THAN THE WASTE OUTLET CAN REMOVE IT.**

SELF CONTAINED MODELS EMPTY INTO AN EVAPORATION PAN THAT WILL OVERFLOW IF TOO MUCH WATER IS INTRODUCED DURING CLEANING.

- Allow merchandisers to dry before resuming operation.
- After cleaning is completed, turn on power to the merchandiser.

 **WARNING**

Product will be degraded and may spoil if allowed to sit in a non-refrigerated area.

 **WARNING**

Do NOT allow cleaning agent or cloth to contact food product.

WARNING

Do NOT use HOT water on Cold glass Surfaces. This can cause the glass to shatter and could result in personal injury. Allow glass fronts, to warm before applying hot water.

REMOVING SCRATCHES FROM BUMPER

Most scratches and dings can be removed using the following procedure.

1. Use steel wool to smooth out the surface area of the bumper.
2. Clean area.
3. Apply vinyl or car wax and polish surface for a smooth glossy finish.

CLEANING UNDER FAN PLENUM

After cleaning be sure the plenum is properly lowered into position OR PRODUCT LOSS WILL RESULT due to improper refrigeration.

WARNING

— LOCK OUT / TAG OUT —

To avoid serious injury or death from electrical shock, always disconnect the electrical power at the main disconnect when servicing or replacing any electrical component. This includes, but is not limited to, such items as doors, lights, fans, heaters, and thermostats.

WARNING

SHUT FANS OFF DURING CLEANING PROCESS.

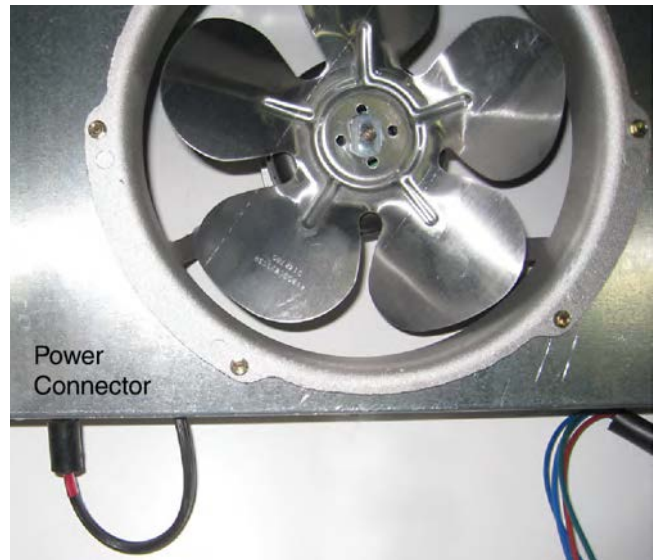

CLEANING DISCHARGE AIR LOUVERS

Discharge air louvers should be cleaned every six months. Dirty louvers will cause merchandisers to perform poorly. The louvers may be cleaned with a vacuum cleaner. Soap and water may be used if all water is removed from the louvers cells before replacing. Be careful not to damage the louvers.

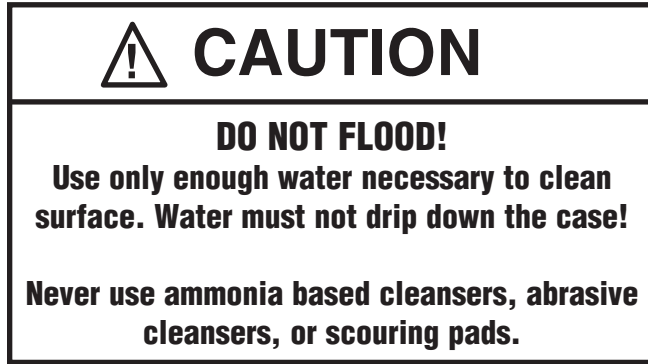

CLEANING STAINLESS STEEL SURFACES

Use non-abrasive cleaning materials, and always polish with grain of the steel. Use warm water or add a mild detergent to the water and apply with a cloth. Always wipe rails dry after wetting.

Use alkaline chlorinated or non-chlorine containing cleaners such as window cleaners and mild detergents. Do not use cleaners containing salts as this may cause pitting and rusting of the stainless steel finish. Do not use bleach.

CLEANING COILS

Condenser coils should be cleaned at least once per month. Additional cleaning may be needed depending on the operational environment. A dirty condenser blocks normal airflow through the coils.

Airflow blockage increases energy consumption and reduces the merchandiser's ability to maintain operating temperature.

To clean the coils, use a vacuum cleaner with a wand attachment and a soft (non-metallic) brush to remove dirt and debris. Do not bend coil fins. Always wear gloves and protective eye wear when cleaning near sharp coil fins and dust particles.

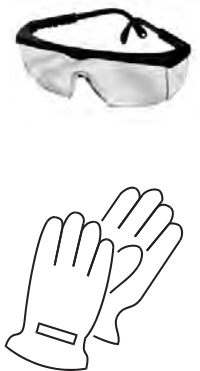

NEVER USE SHARP OBJECTS AROUND COILS. Use a soft brush or vacuum brush to clean debris from coils. *Do not puncture coils!* Do not bend fins. Contact an authorized service technician if a coil is punctured, cracked, or otherwise damaged.

ICE in or on the coil indicates the refrigeration and defrost cycle is not operating properly. Contact an authorized service technician to determine the cause of icing, and to make adjustments as necessary. To maintain product integrity, move all product to a cooler until the unit has returned to normal operating temperatures.



CAUTION

Evaporation Pan is Hot!

and poses risk of bodily injury – Always Wear gloves and protective eye wear when servicing. Turn off evaporation pan heater, and allow pan to cool.

CLEANING EVAPORATION PAN

(SELF CONTAINED ONLY)

The condensate water outlet for self contained models empties into a limited capacity evaporation pan.

Debris or dirt accumulation inside the condensate evaporation pan or on the heater coil will reduce the pan's evaporation capacity and cause premature heater failure. The evaporation pan waste water will overflow and spill onto the floor if the heater is not properly operating.

Remove accumulated debris from the evaporation pan. Wipe down heater coil with a cloth and warm water. Be sure to remove any dirt, debris or liquids from the heater coil.

Water introduced during cleaning will cause the evaporation pan to overflow.



PRECAUTION CLEANING PRECAUTIONS

When Cleaning:

- Do not use high pressure water hoses
- Do not introduce water faster than waste outlet can drain
- NEVER INTRODUCE WATER ON SELF CONTAINED UNIT WITH AN EVAPORATION PAN
- NEVER USE A CLEANING OR SANITIZING SOLUTION THAT HAS OIL BASE (these will dissolve the butyl sealants) or an AMMONIA BASE (this will corrode the copper components of the merchandiser)
- TO PRESERVE THE ATTRACTIVE FINISH:
 - Use a water and a mild detergent for the exterior only
 - Do NOT use a chlorinated cleaner on any surface
 - Do NOT use abrasives or steel wool scouring pads (these will mar the finish)

Self-Contained Refrigeration Equipment Maintenance Check List

***** Warranty does not cover issues caused by improper installation or lack of basic preventative maintenance. *****	
Record starting date	
Store Name and Number	
Store Address	
Unit Model Number	
Unit Serial Number	
Contractor/Technician	

	Technician		Q1	Q2	Q3	Q4	Q1	Q2	Q3	Q4
	Quarterly	Semi-Annually								
PM activity-For visual inspection items, denote "ok or complete" in the column to right when PM has been performed. For measured data requested, record data requested in the appropriate column to the right)										
Check in with store manager, record any complaints or issues they have with unit.	X									
Look unit over for any damage, vibrations or abnormal noise.	X									
Verify unit is level side to side and front to rear.	X									
Confirm refrigerant lines properly are secured and not touching or rubbing other lines, wires or frame work.	X									
Verify fan motors and motor mounts are tight.	X									
Confirm fan blade/s are tight and not rubbing or hitting.	X									
Make sure all electrical connections, factory and field, are tight.	X									
Verify electrical connections at lamps are they secure and dry.	X									
Check for and replace any frayed or chaffed wiring.	X									
Check all electrical wiring make sure it is secured and not on any sharp edges or hot lines.	X									
Check for air disturbances external to the unit. Heat and air registers, fans, and doors etc.	X									
Check for water leaks.	X									
Clean evaporator coil/s and fan blade/s. Do not use an acid base cleaner. Rinse off any cleaner residue.		X								
Clean discharge air honeycombs or grilles. Do not use an acid base cleaner. Rinse off any cleaner residue.		X								
Clean condenser coil/s and fan blade/s. Do not use an acid base Cleaner. Rinse off any cleaner residue.		X								
Clean condensate drain pan and drain line.		X								
Verify condensate drain lines are clear and functioning.		X								
Record voltage reading at unit with unit off?		X								
Verify condenser and evaporator fans are working.	X									
Record condenser air inlet temperature	X									
Record condenser air outlet temperature	X									
Is condenser air inlet or air exhaust restricted or recirculating?	X									
Verify there are no visual oil or refrigerant leaks.	X									
Record voltage reading with unit running.		X								
Record compressor amp draw.		X								
Record defrost heater voltage and amp draw.		X								
Record anti-sweat heater voltage and amp draw.		X								
Record case product temperature.	X									
Record unit discharge air temperature.	X									
Record unit return air temperature.	X									
Record ambient conditions around unit (wet Bulb temperature and dry bulb temperature).	X									
Check product loading, do not load beyond the units load limits.	X									
Verify clearances on sides/back of unit.	X									
Check unit controller for proper operation. See controller or 1/0 Manual for proper controller operation.		X								
Confirm door switches function.	X									
Verify unit doors and lids work and are sealed correctly.	X									
Verify that all the panels, shields and covers are in place.	X									

Technician Notes:

NOTES:

SERVICE

REPLACING FAN MOTORS AND
BLADES

Should it ever be necessary to service or replace the fan motors or blades be certain that the fan blades are reinstalled correctly. **THE BLADES MUST BE INSTALLED WITH RAISED EMBOSING (PART NUMBER ON PLASTIC BLADES) POSITIONED AS INDICATED ON THE PARTS LIST.**

For access to these fans:

1. Remove product and place in a refrigerated area. Turn off power to the merchandiser.
2. Remove bottom display pans.
3. **Disconnect fan from wiring harness.**
4. Remove fan blade.
5. Lift fan plenum and remove screws holding bottom of motor to fan basket.
6. Replace fan motor and blade.
7. Lower fan plenum.
8. Reconnect fan to wiring harness.
9. Turn on power.
10. Verify that motor is working and blade is turning in the correct direction.



WARNING

— LOCK OUT / TAG OUT —

To avoid serious injury or death from electrical shock, always disconnect the electrical power at the main disconnect when servicing or replacing any electrical component. This includes, but is not limited to, such items as doors, lights, fans, heaters, and thermostats.

11. Close air gaps under fan plenum. Warmer air moving into refrigerated air reduces effective cooling. If the plenum does not rest against the case bottom without gaps, apply foam tape to the bottom of the fan plenum to reduce improper air movement. Use silicone sealant to close other gaps.
12. Reinstall display pans. Bring merchandiser to operating temperature before restocking.

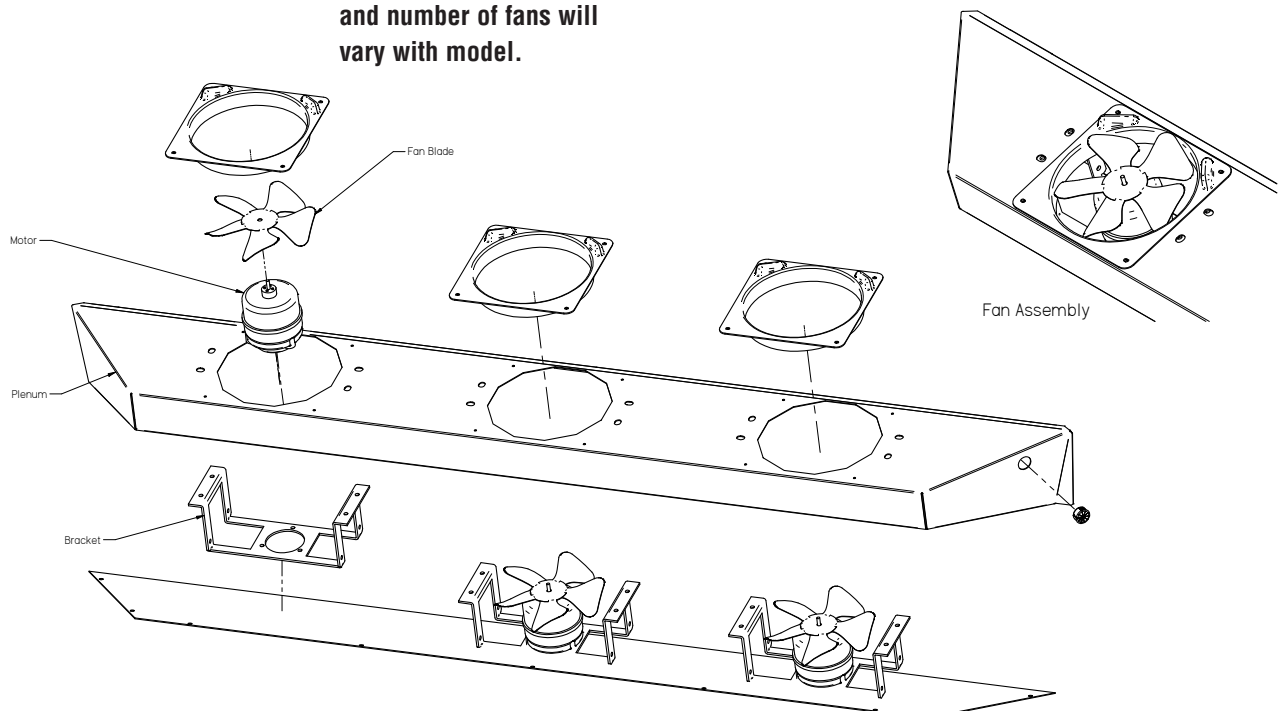
Note: Plenum length and number of fans will vary with model.



Replacement Parts List

Standard Parts

Description	Part Number
Black End Trim	1750301121
End Plexiglass	0552802
Caster	175018505
Drain Trap	18S279
Cover Drain	0301266
Thermometer (solar)	0517730
Black bumper	1H19068700
Black bumper end cap	1H19070700
Black bumper corner	1H19069700
Aluminum bumper base	175035002
Black Telescopic shelf	0514078
Front plexiglass 11"	0552793
Front plexiglass 8.5"	0552794
Front plexiglass for shelf	0552785
Binding screw #8-32 1/4	300030604
Post binding #8-32 1/2	175010369
LED light	3004894
Clip for LED light	0523762
Switch LED light	3033238
Power supply 1000w 24VDC	0547639
Fuse 15 amp	125018604
Fuse holder	125018605
Front Panel Rustic Maple	0556976
End Frame Rustic Maple RH	0556977
End Frame Rustic Maple LH	0556978

Refrigeration

Description	Part Number
Distributor (Sporlan 1620)	1H18877500
Heat exchanger	00008480
Evaporator	050033700
Plastic collar fan	0409510
Aluminum fan blade (6.70")	0428111
Evaporator fan motor (230V, 4W)	0477659
Bracket fan motor	0552827
Sight glass (Sporlan SA-13)	225010075
Drier (Sporlan C-163-S)	225010660
Condensing unit main switch	125010271

Refrigeration

Description (R404A)	Part Number
Expansion valve (Danfoss 068U2139)	0460972
Condensing unit (M4FF-0080-IAV-212)	1H28154500

Refrigeration

Description (R448A)	Part Number
Expansion valve R448 (Sporlan EGSE 1 / 2 C)	3031934
Condensing unit (M6GP-H090-CAV-212)	3082678

Replacement Parts List CONTINUED

Heaters and Harnesses

Description	Part Number
Evap Pan 1500W-240V	1H95137550
Power cord L6-20P	0553285
Canopy LED harness	0523772
Shelf LED harness (male)	0523768
Shelf LED harness (female)	1H26295550

Sheet Metal Replacement Parts Painted

Description	Part Number
Shelf	0552805
Rear top cover	0552848
Rear bottom grill	0552888
Bracket moun rack	0552788
Air deck pan (top)	0552840
Air deck pan (bottom)	0552846
Back panel RH (thermometer)	0552860
Back panel LH (sensor)	0552863
Cover bottom close off**	0554557
Liner RH close off**	0554558
Liner LH close off**	0554559

Controller Parts

Description	Part Number
Control AK-CC210 (230V) & Sensors (1.5m, 3.5m)	0524077
Compressor relay (220V)	1804241

Q3SS6S

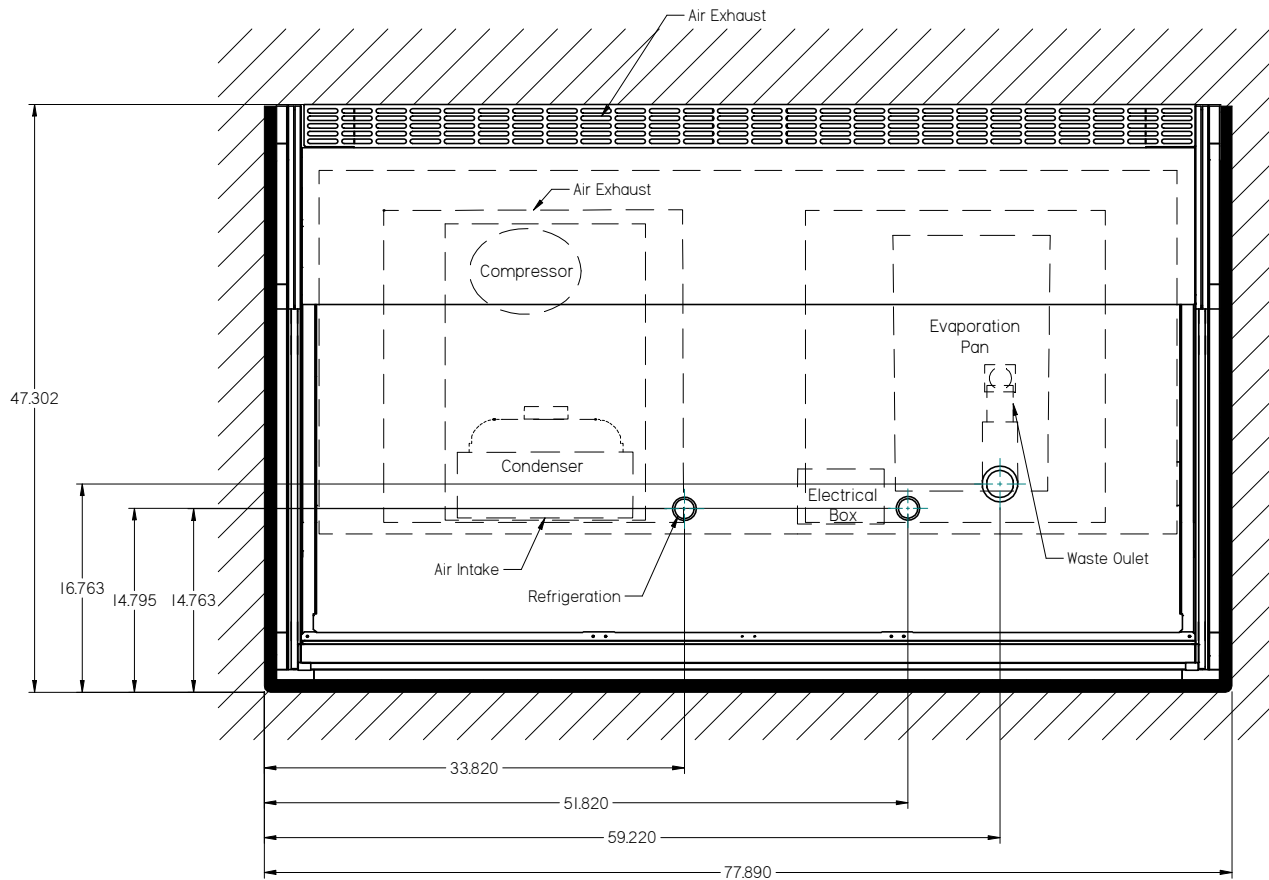

Dimensions shown as inches and (mm).

General

Case Length (<i>Note: Includes One Pair Ends</i>)	75.89" (193)
Optional End Bumpers (<i>One Pair</i>)	1" (2.54) Bumper
Maximum O/S dimension of case back to front (<i>Note: Includes bumper</i>)	47.30" (120.14)

Waste Outlet

LH end of case (<i>from outside of End Assembly</i>) to center of waste outlet	58.22" (147.88)
---	-----------------

Q3SS6S

Dimensions shown as inches

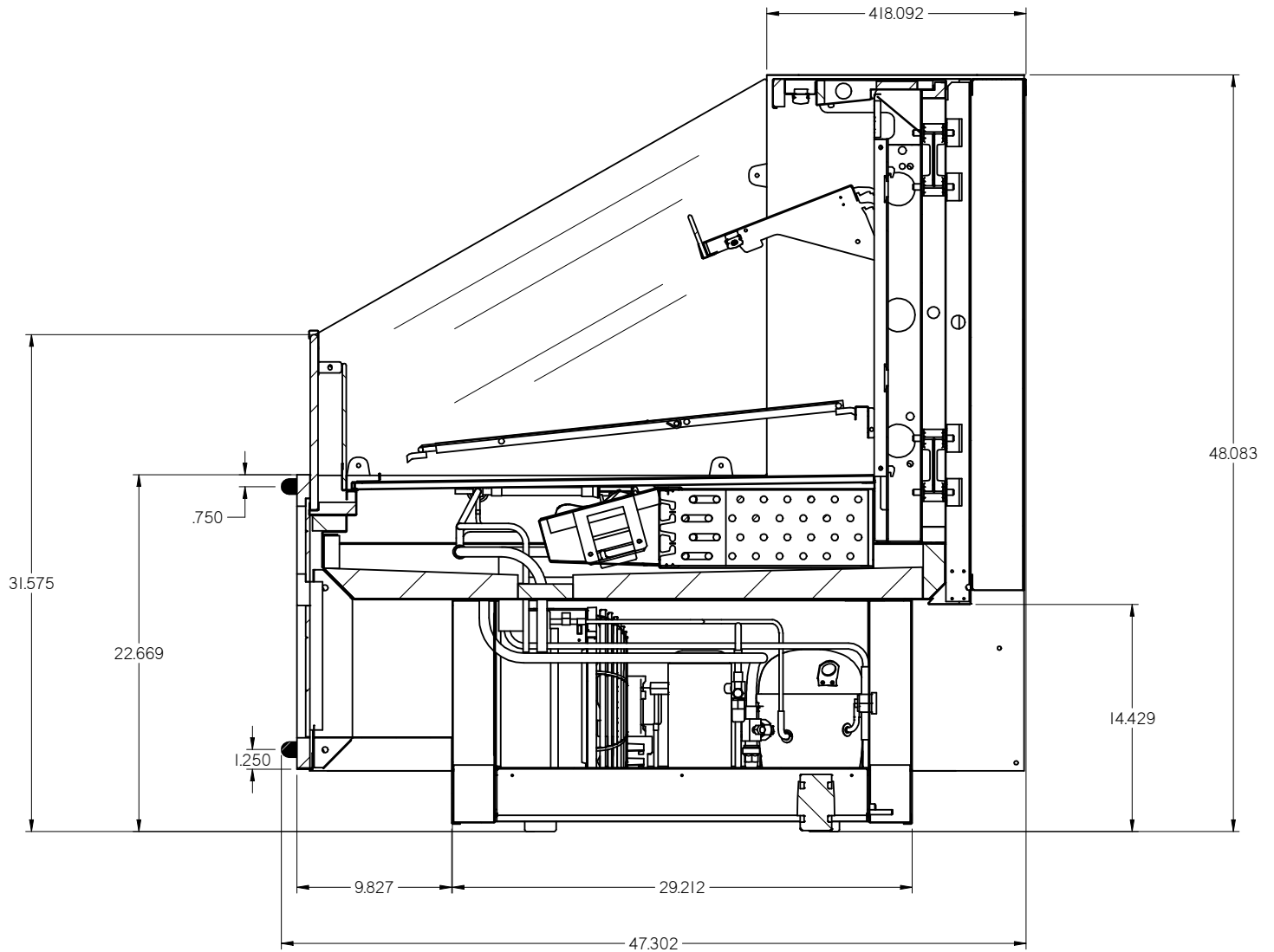

REFRIGERATION DATA

Q3SS6S

Condensing Unit (hp) 0.75

**Condensing Unit
Capacity** 1,080
(Btu/hr at std. rating
conditions)

Note: This data is based on store temperature and humidity that does not exceed 75°F and 55% R.H. unless otherwise stated. Schedule defrost at night while lights are off.

DEFROST DATA

Frequency (hr) 6

OFFTIME

Failsafe (minutes) 50

**Defrost Termination
Temperature °F** 48

PHYSICAL DATA

Refrigerant Charge **R404A**
89.6 oz 2.54 kg

Refrigerant Charge **R448A**
48 oz 1.362 kg

ELECTRICAL DATA

Note: These are rated values for individual components and should not be added together to determine total merchandiser electrical load.

Number of Fans: 3 (4 watt) fans

	Amps	Watts
Evaporator Fans		
Condensate Pan Heaters (208V)	5.42	1500

PRODUCT DATA

*AHRI Total Display Area*¹ (Sq Ft/Case) 26.94 ft² /case (2.50 m² /case)

Computed using AHRI 1200 standard methodology:
 Total Display Area, ft² [m²] / Unit of Length, ft [m]

Model	Nominal HP	Refrigerant Type	Volts	Run Amps	Nema Plugs	Fuse Amps	Hz/Ph
Q3SS6S	3/4 HP	R404A/R448A	208/230	14.7	L6-20P	20	60/1

ESTIMATED SHIPPING WEIGHT ²

Case

Q3SS6S

882 lb (400 kg)

1047 lb (475 kg)
(with shipping crate)

End

Included

² Actual weights will vary according to optional kits included.

Color Code For Wiring Diagram on Next Page

WARNING

All components must have mechanical ground, and the merchandiser must be grounded.

CIRCLED NUMBERS = PARTS LIST ITEM NUMBERS

R = Red Y = Yellow G = Green BL = Blue BK = Black W = White

● = 120V POWER ○ = 120V NEUTRAL ⊥ = FIELD GROUND ≡ = CASE GROUND

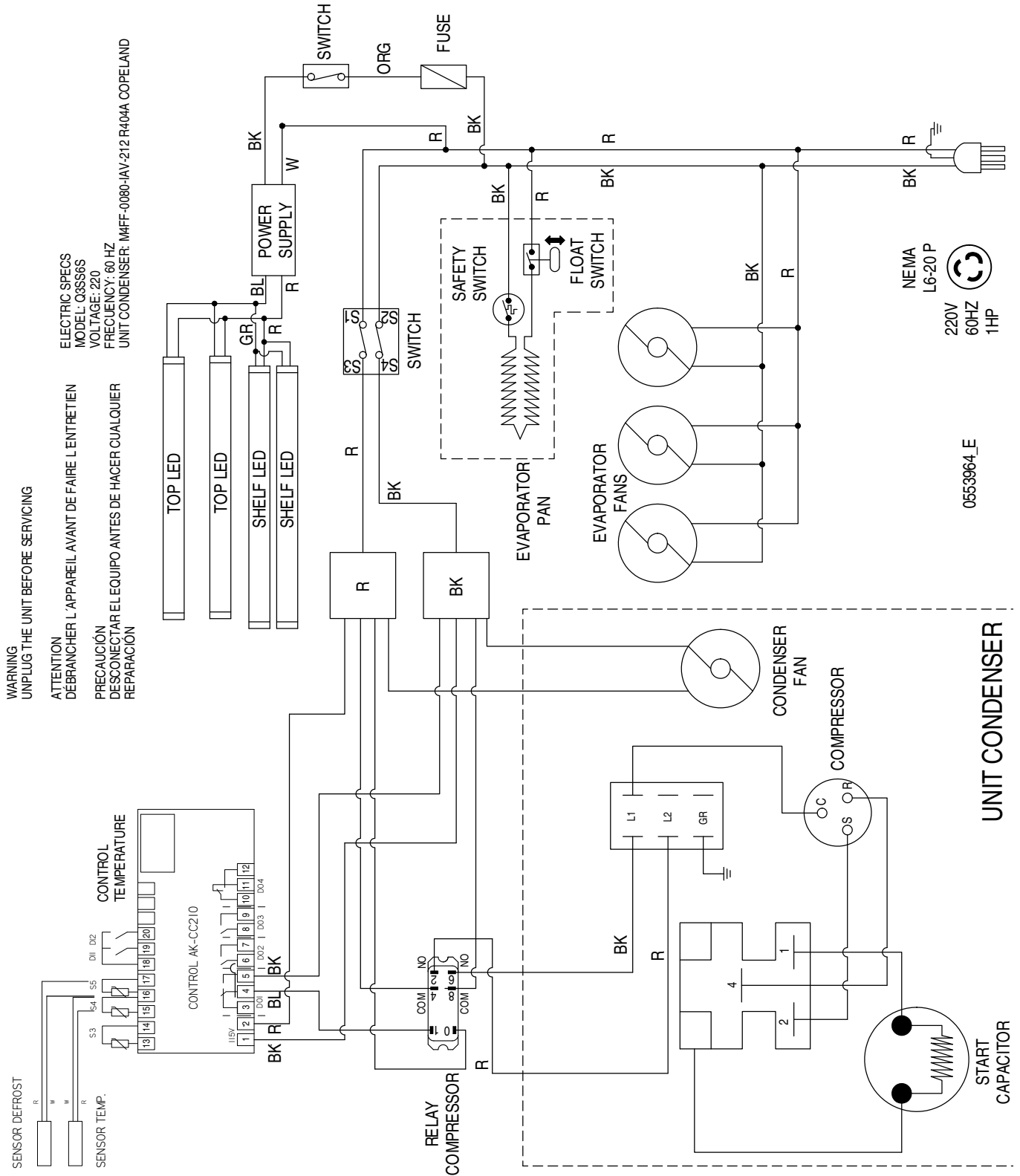

WARNING
UNPLUG THE UNIT BEFORE SERVICING

ATTENTION
DÉBRANCHER L'APPAREIL AVANT DE FAIRE L'ENTRETIEN

PRECAUCIÓN
DESCONECTAR EL EQUIPO ANTES DE HACER CUALQUIER REPARACIÓN

ELECTRIC SPECS
MODEL: Q3SS6S
VOLTAGE: 220
FREQUENCY: 60 HZ
UNIT CONDENSER: W4FF-0080-1AV-212 R404A COPELAND

NEMA
L6-20 P
220V
60HZ
1HP

0553964_E



HUSSMANN[®]

**To obtain warranty information
or other support, contact your
Hussmann representative.
Please include the model and
serial number of the product.**