

*Insight standard field electrical connections are at the top left of the merchandiser*

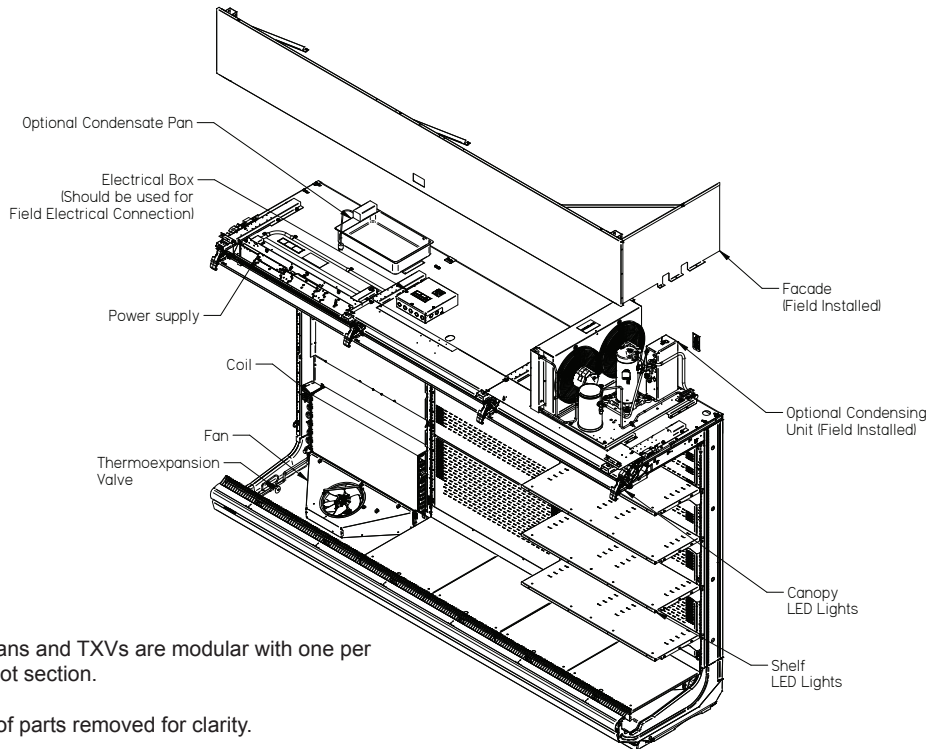

\*Coils, fans and TXVs are modular with one per 3 or 4 foot section.

Portion of parts removed for clarity.

12 foot merchandiser shown.

### NSF Certification

This merchandiser model is manufactured to meet NSF/ANSI (National Sanitation Foundation) Standard #7 requirements for construction, materials and cleanability.



**IMPORTANT**

**DRAIN EXTENSION KIT REQUIRED TO PIPE MULTIPLE CASES TO ONE DRAIN, OR TO USE A RAISED HUB DRAIN. SEE PAGE 6 FOR DETAILS.**

Performance Data	Page 2	Estimated Shipping Weights	Page 8
Product Data (AHRI Statistics)	Page 2	Shelf Options	Page 8
Cross Section	Page 4	Wiring Diagrams	Page 9
Plan View	Page 5	QR Code for Parts and Product Information	Page 12
Electrical Loads	Page 7	Revision History	Page 12

Data sheet-Insight IDF6NU

We reserve the right to change or revise specifications and product design in connection with any feature of our products. Such changes do not entitle the buyer to corresponding changes, improvements, additions or replacements for equipment previously sold or shipped.

**Insight IDF6NU**  
**Dairy / Delicatessen /**  
**Meat**

**Refrigeration Data <sup>1</sup>**

IDF6NU		Optimal Shelf Life			Energy Comparison
Application		Dairy/Deli/ Beverage/ Produce <sup>1</sup>	Convertible / Meat <sup>1</sup>	NSF Type 2 Ambient <sup>3</sup>	AHRI 1200 Rating Point <sup>1,4</sup>
Unlit Shelves	Discharge Air °F (°C)	33 (0.6)	33 (0.6)	34 (1.1)	35 (1.7)
	Average Evaporator °F (°C) <sup>2</sup>	28 (-2.2)	26 (-3.3)	26 (-3.3)	30 (-1.1)
	Parallel Btu/hr/ft (Watts/m)	1380 (1327)	1664 (1600)	1806 (1736)	1334 (1283)
	Conventional Btu/hr/ft (Watts/m)	1505 (1447)	1815 (1745)	1970 (1984)	1455 (1399)
Lit Shelves <sup>5</sup>	Discharge Air °F (°C)	32 (0)	32 (0)	33 (0.55)	34 (1.1)
	Average Evaporator °F (°C) <sup>2</sup>	27 (-2.8)	25 (-3.9)	25 (-3.9)	29 (-1.7)
	Parallel Btu/hr/ft (Watts/m)	1389 (1335)	1673 (1609)	1815 (1745)	1343 (1291)
	Conventional Btu/hr/ft (Watts/m)	1515 (1457)	1825 (1755)	1980 (1904)	1465 (1409)
Fan Speed <sup>6</sup>	IDF6NU6 (10.3")	1300 <sup>6</sup>	1600 <sup>6</sup>	1600 <sup>6</sup>	1300 <sup>6</sup>
	IDF6NU4, 8, 12 (10.3")	1300 <sup>6</sup>	1600 <sup>6</sup>	1600 <sup>6</sup>	1300 <sup>6</sup>

Notes:

- All data based on store temperature and humidity that does not exceed NSF Type 1 ambient conditions of 75°F and 55% relative humidity except where noted.
- Average evaporator temperature shown. Use dew point for high glide refrigerants for unit sizing. Care should be taken to use the dew point in PT tables for measuring and adjusting superheat. Adjust evaporator pressure as needed to maintain discharge air temperature shown.
- Data for operation in NSF Type 2 ambient of 80°F and 55% relative humidity.
- AHRI 1200 Rating Point for energy consumption comparison only.
- Add 10 Btu/hr/ft (9.6 Watts/m) per shelf row for LED shelf light fixtures.
- Some lengths and/or applications require optional fan speed control kits applied by the Hussmann Product Configurator.

**Defrost Data**

<b>Frequency</b> (hours between defrost)	4
<b>Defrost Water</b> <sup>7</sup>	10.3 lb/ft/day (15.3 kg/m)
<sup>7</sup> (± 15% based on case configuration and product loading).	
<b>OFFTIME</b>	<b>IDF6NU</b>
<b>Time (minutes)</b>	20
<b>ELECTRIC OR GAS</b>	Not Available

**Conventional Controls**

	<b>IDF6NU</b>
<b>Low Pressure Backup Control CI/CO</b> <sup>8</sup>	20°F / 10°F -6.7°C / -12.2°C
<b>Indoor Unit Only, Pressure Defrost Termination</b> <sup>8</sup>	48°F (8.9°C)

<sup>8</sup> Use a Temperature Pressure Chart to determine PSIG conversions.

**Product Data**

<b>Gross Refrigerated Volume</b> <sup>9</sup> (Cu Ft/Ft)	10.8 ft <sup>3</sup> /ft (1.00 m <sup>3</sup> /m)
<b>AHRI Total Display Area</b> <sup>10</sup> (Sq Ft/Ft)	5.55 ft <sup>2</sup> /ft (1.69 m <sup>2</sup> /m)
<b>Shelf Area</b> <sup>11</sup> (Sq Ft/Ft)	9.58 ft <sup>2</sup> /ft (2.92 m <sup>2</sup> /m)

<sup>9</sup> AHRI Gross Refrigerated Volume: Refrigerated Volume/Unit of Length, ft<sup>3</sup>/ft [m<sup>3</sup>/m]

<sup>10</sup> Computed using AHRI 1200 standard methodology: Total Display Area, ft<sup>2</sup> [m<sup>2</sup>]/Unit of Length, ft [m]

<sup>11</sup> Shelf surface area is composed of bottom deck plus standard shelf complement for this model: (5) rows of 18-in. shelves

## Refrigeration Data Continued

### Total Working Refrigerant Charge<sup>12</sup>

#### Air-Cooled

*With Recommended Condensing Unit Installed*

<b>4 ft</b>	6 lb 10 oz	/	3.00 kg
<b>6 ft</b>	7 lb 2 oz	/	3.23 kg
<b>8 ft</b>	9 lb 10 oz	/	4.36 kg
<b>12 ft</b>	11 lb	/	5.00 kg

#### Water -Cooled

*With Recommended HMDSLMT Condensing Unit Installed*

<b>4 ft</b>	3 lb 10 oz	/	1.64 kg
<b>6 ft</b>	3 lb 13 oz	/	1.73 kg
<b>8 ft</b>	4 lb	/	1.82 kg
<b>12 ft</b>	5 lb 8 oz	/	2.50 kg

<sup>12</sup>The Total Refrigerant Charge includes the case and condensing unit. Both ship pre-charged with a portion of the total refrigerant

**Insight IDF6NU**  
Dairy / Delicatessen /  
Meat

Insight Freedom Multideck Merchandiser, 6 Display  
Levels, Narrow Bottom, Ultra Low Front

**DOE 2017**  
Energy Efficiency  
Compliant

Hussmann refrigerated merchandisers configured for sale for use in the United States meet or surpass the requirements of the DOE 2017 energy efficiency standards.

Dimensions shown as in. and (mm).

Other optional kits (top piping and vent fans) add to the overall case height.

A minimum 1 1/2-in. clearance required to remove raceway cover, 6 1/2-in. for full access. See the Installation manual for instructions.

3-in. between back to back cases.

Shelf complement shown as tested:

Five rows of 18-in. shelves spaced equally between bottom display pan and interior top panel.

Shown with Standard Faceted Canopy.

**OPTIONAL RAIL LIGHT**

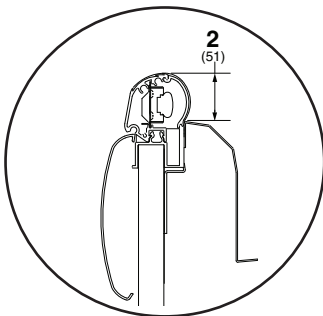

**IDF6NU**

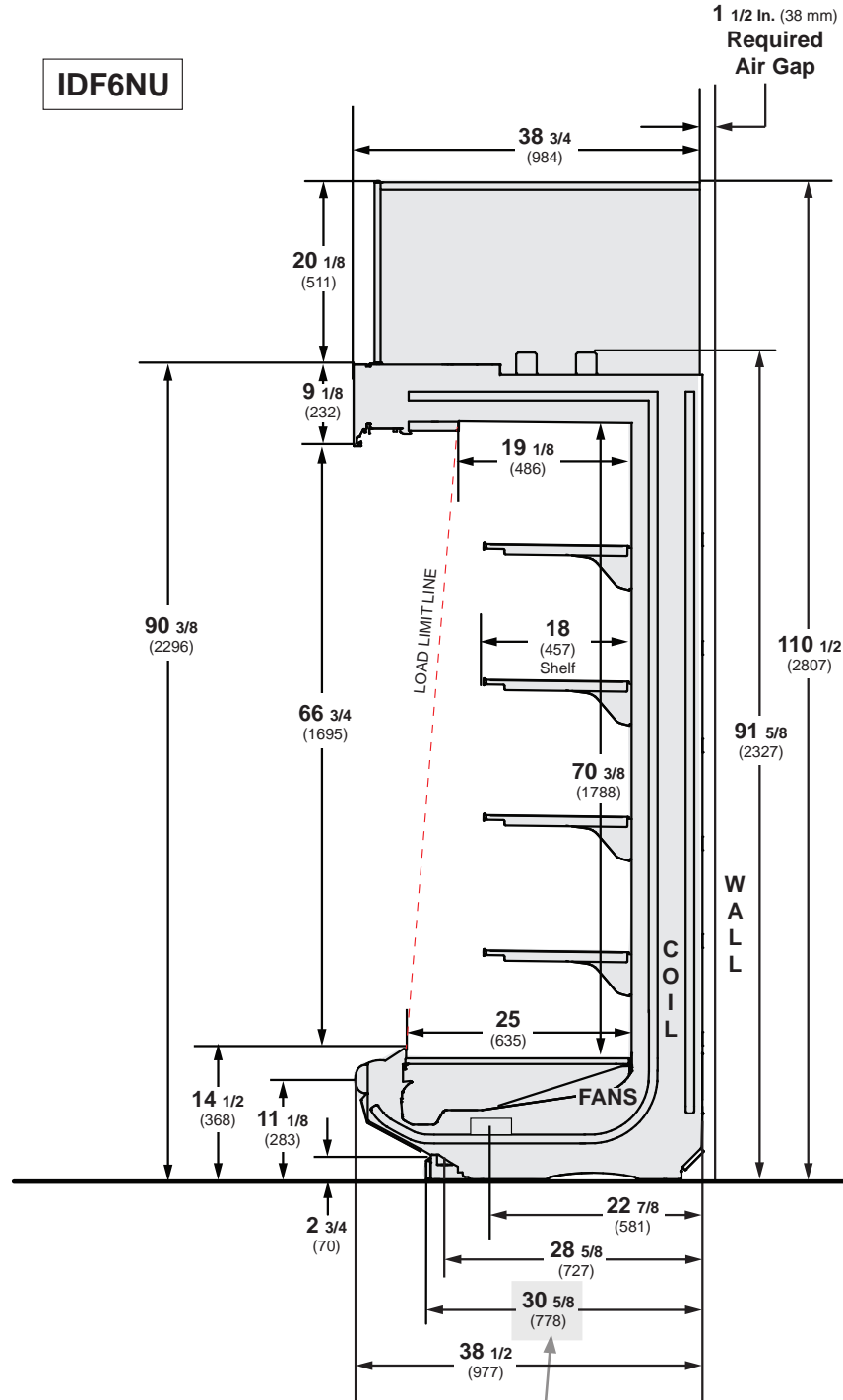

1 1/2 in. (38 mm)  
**Required Air Gap**

**NOTE:**

If extended drain kits are used, the distance from back of case (not including air gap) increases to 35 1/8 inches. This may affect floor drain layout. See Page 6 for more details.

**WARNING: Floor Drain must be located within 24 inches of Waste Outlet.  
See page 6 for Drain Extension Option (must be used with hub-style floor drains).**

# Engineering Plan View

Dimensions shown as in. and (mm).

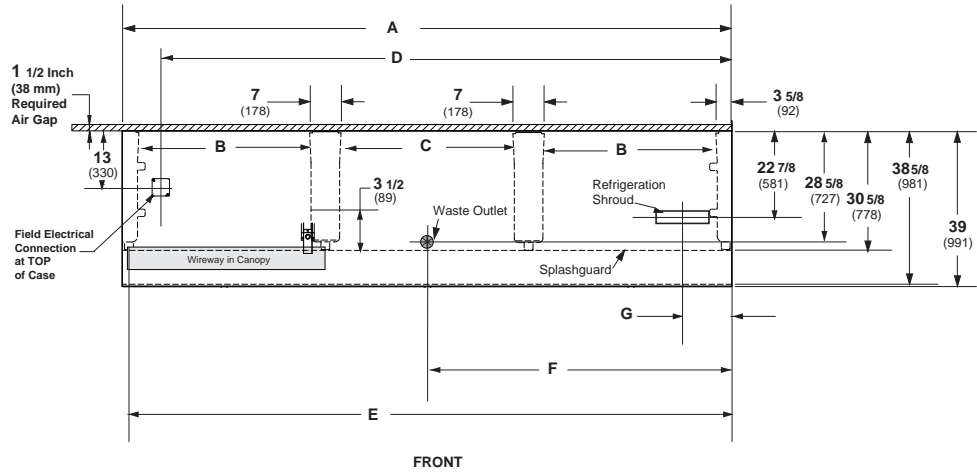

(12 Foot Model shown above)

	4 ft	6 ft	8 ft	12 ft
<b>General</b>				
(A) Case Length (without ends or partitions) (Each end and insulated partition adds 1 1/2 in. (38 mm) to case line up.)	48 1/8 (1222)	72 1/4 (1835)	96 1/4 (2445)	144 3/8 (3668)
Maximum O/S dimension of case back to front (includes bumper)	38 5/8 (981)	38 5/8 (981)	38 5/8 (981)	38 5/8 (981)
Back of case to front of splashguard	30 5/8 (778)	30 5/8 (778)	30 5/8 (778)	30 5/8 (778)
(B) Distance between edges of external legs and center legs	NA	29 (737)	41 (1041)	41 (1041)
(C) Distance between edges of center legs	41 1/8 (1045)	NA	NA	41 1/8 (1045)
Distance between front legs and splashguard	3 1/4 (83)	3 1/4 (83)	3 1/4 (83)	3 1/4 (83)
<b>Electrical Service (Field Electrical Wiring Connection)</b>				
(D) RH End of case to center of Field Electrical Wiring Connection (top of case)	39 3/8 (1000)	63 1/2 (1613)	87 1/2 (2223)	135 1/2 (3442)
Back of case to center of Field Electrical Wiring Connection	13 (330)	13 (330)	13 (330)	13 (330)
Length of electrical wireway	44 5/8 (1133)	33 1/2 (851)	45 7/8 (1165)	45 7/8 (1165)
(E) RH end of case to LH end of electrical wireway (top of case)	46 1/2 (1181)	70 1/2 (1791)	94 1/2 (2400)	142 5/8 (3630)
<b>Waste Outlets (see page 5 for drain extension option)</b>				
(F) RH End of case to the center of waste outlet	24 1/8 (613)	24 1/8 (613)	24 1/8 (613)	72 1/4 (1835)
Back O/S of case to center of waste outlet(s)	28 5/8 (727)	28 5/8 (727)	28 5/8 (727)	28 5/8 (727)
Schedule 40 PVC drip pipe	1 1/4 (32)	1 1/4 (32)	1 1/4 (32)	1 1/4 (32)
<i>Floor Drain must be located within 24 inches of Waste Outlet.</i>				
<b>Refrigeration Shroud</b>				
(G) Back of case to center of refrigeration shroud	22 7/8 (581)	21 1/8 (537)*	22 7/8 (581)	22 7/8 (581)
End of case to center of refrigeration shroud	9 1/2 (241)	7 5/8 (194)*	9 1/2 (241)	9 1/2 (241)
*6 foot case at 42° angle, parallel to the plenum.				

**Drain Extension Option**  
(Partial End View)

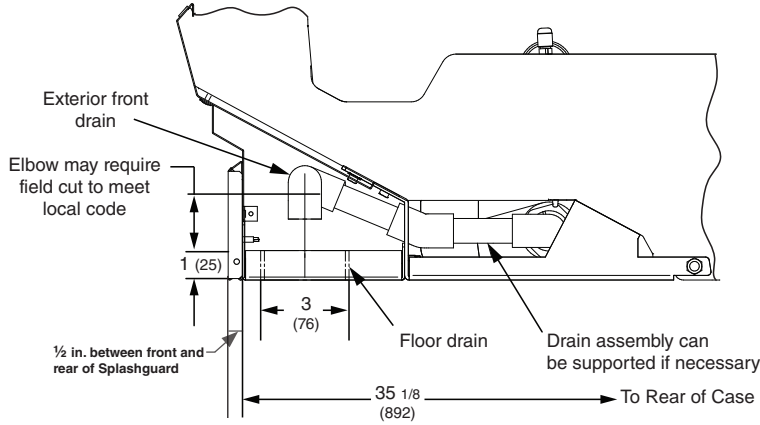

**IMPORTANT:** If hub drain is used in lieu of flush floor sink, a drain extension kit must be installed. Hub drains must be located in front of the waste outlet to achieve adequate air gap.

**Engineering  
Plan View**

Dimensions shown as in. and (mm).

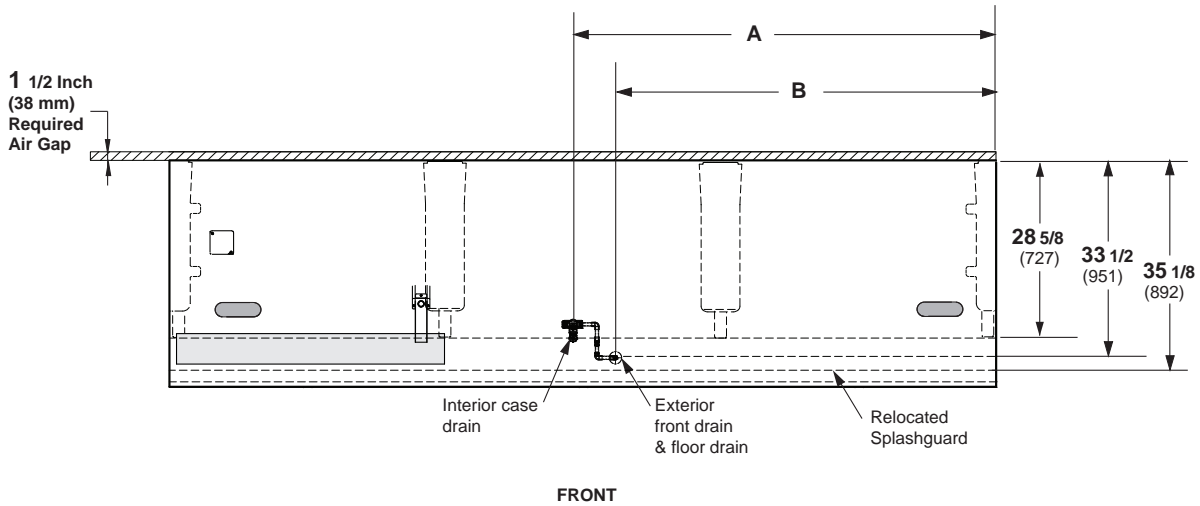

(12 Foot Model shown above)

	4 ft	6 ft	8 ft	12 ft
<b>Waste Outlet Drain Option</b>				
(A) RH of case to center of interior case drain	24 1/8 (613)	24 1/8 (613)	24 1/8 (613)	72 1/4 (1835)
(B) RH of case to center of exterior front drain and floor drain	13 3/4 (349)	13 3/4 (349)	13 3/4 (349)	61 7/8 (1572)

## Electrical Data

<b>Number of Fans</b>	<b>4 ft</b>	<b>6 ft</b>	<b>8 ft</b>	<b>12 ft</b>
10.3-in.	1	2	2	3

				<b>Amperes</b>				<b>Watts</b>			
				<b>4 ft</b>	<b>6 ft</b>	<b>8 ft</b>	<b>12 ft</b>	<b>4 ft</b>	<b>6 ft</b>	<b>8 ft</b>	<b>12 ft</b>
<b>Evaporator Fan</b>											
120V	60Hz	Energy Efficient		0.40	0.80	0.80	1.20	24	48	48	72
230V	50/60Hz	Energy Efficient		0.21	0.42	0.42	0.62	24	48	48	72

### Minimum Circuit Ampacity

120V	60Hz	Energy Efficient	1.60	2.59	3.19	4.80
230V	50/60Hz	Energy Efficient	0.83	1.35	1.66	2.49

### Maximum Over Current Protection

120V	20	20	20	20
230V	15	15	15	15

## Lighting

ONLY LIGHTING CONFIGURATIONS THAT ARE COMPLIANT WITH THE U.S. DEPT. OF ENERGY (DOE) 2017 REGULATION ARE AVAILABLE FOR SALE FOR USE IN THE U.S.A.

				<b>Amperes</b>				<b>Watts</b>			
				<b>4 ft</b>	<b>6 ft</b>	<b>8 ft</b>	<b>12 ft</b>	<b>4 ft</b>	<b>6 ft</b>	<b>8 ft</b>	<b>12 ft</b>
<b>STANDARD LIGHTING</b>											
<b>Canopy</b>											
1 Row	0.16	0.26	0.32	0.48	19.3	31.6	38.6	58.0			
<b>OPTIONAL LIGHTING</b>											
<b>Canopy</b>											
1 Row HO	0.22	0.33	0.44	0.66	26.5	39.5	53.0	79.4			
<b>Shelf</b>											
1 Row of Shelves	0.08	0.12	0.16	0.25	9.9	14.1	19.8	29.7			
2 Rows of Shelves	0.16	0.23	0.33	0.49	19.8	28.2	39.5	59.3			
3 Rows of Shelves	0.25	0.35	0.49	0.74	29.7	42.3	59.3	89.0			
4 Rows of Shelves	0.33	0.47	0.66	0.99	39.5	56.4	79.1	118.6			
5 Rows of Shelves	0.41	0.59	0.82	1.24	49.4	70.5	98.9	148.3			
6 Rows of Shelves	0.49	0.70	0.99	1.48	59.3	84.5	118.6	178.0			
7 Rows of Shelves	0.58	0.82	1.15	1.73	69.2	98.6	138.4	207.6			
<b>Rail Light</b>											
1 Row	0.08	0.12	0.16	0.25	9.9	14.1	19.8	29.7			

120V Lighting Circuit Total = Standard Lighting + Total Optional Lighting + Optional Shelf Lighting

230V Lighting Circuit Total = Multiply 120V Lighting Circuit Total by 0.52

**Insight IDF6NU**  
 Dairy / Delicatessen /  
 Meat

**ENDS or PARTITIONS**

*Each standard end and each insulated partition adds 1 1/2 in. (38 mm) to case line up. Optional view end with end bumper adds 3 3/4 in. (95 mm).*

**PHYSICAL DATA**

Merchandiser Drip Pipe (in.)	1 1/4
Schedule 40 PVC	
Merchandiser Liquid Line (in.)	3/8
Merchandiser Suction Line (in.)	7/8

**ESTIMATED SHIPPING WEIGHT †**

Case					Solid End
	4 ft	6 ft	8 ft	12 ft	(each)
<b>lb (kg)</b>	850 (386)	1050 (476)	1250 (567)	1650 (748)	100 (45)

† Actual weights will vary according to optional kits included.

**Shelf Options**

Approved shelf sizes for standard (horizontal, 2-3 position brackets) displays:

- 14-inch
- 16-inch
- 18-inch

Contact engineering for non-standard (4 position brackets or other) display recommendations.

Minimum number of Shelves: 4

Optimal number of Shelves: 5

Maximum number of Shelves: 8

Maximum number of Lighted Shelves: 7

Standard shelf complement for test purposes: (5) rows of 18-in. shelves evenly distributed vertically.



# Fan Wiring Offtime Defrost

**Insight IDF6NU**  
Dairy / Delicatessen /  
Meat

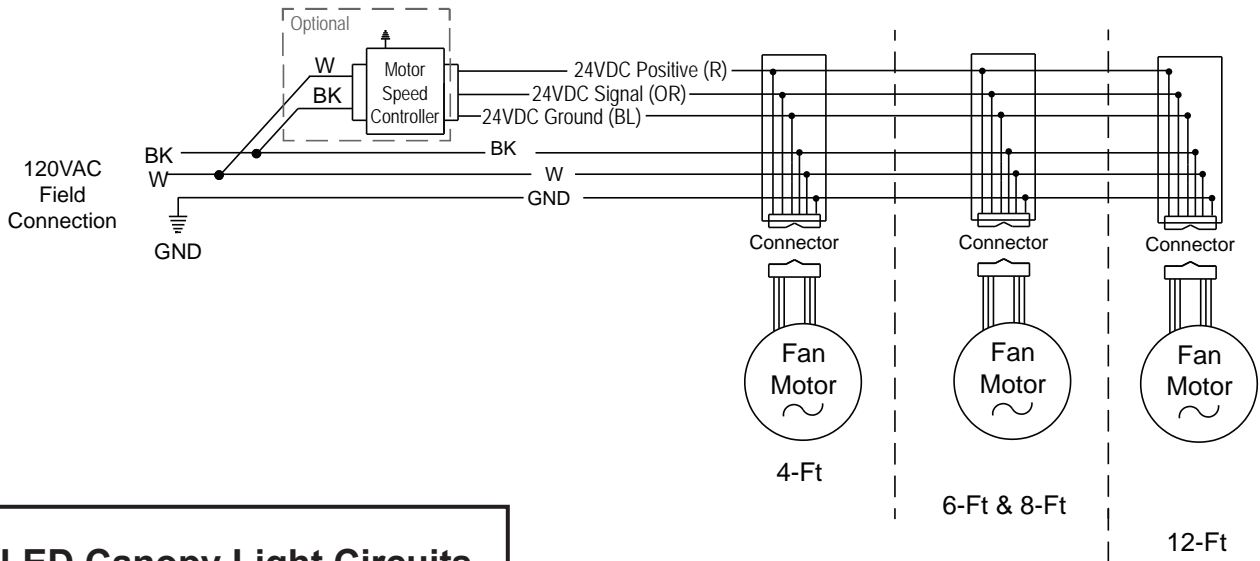

# LED Canopy Light Circuits

## EcoShine II LED Canopy Lighting - 1 Row

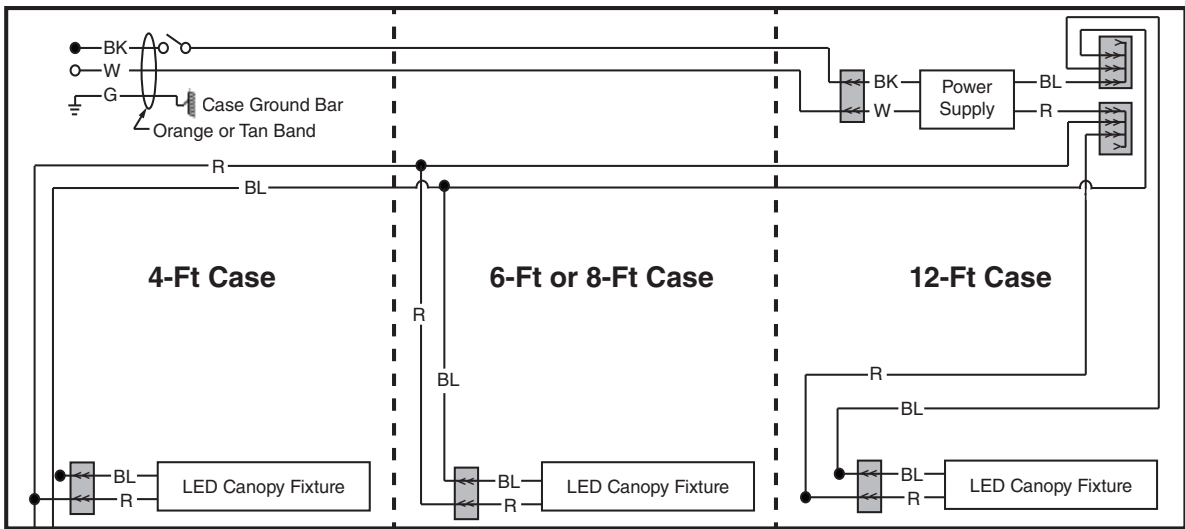

## Optional Lighting - EcoShine II LED Rail - 1 Row

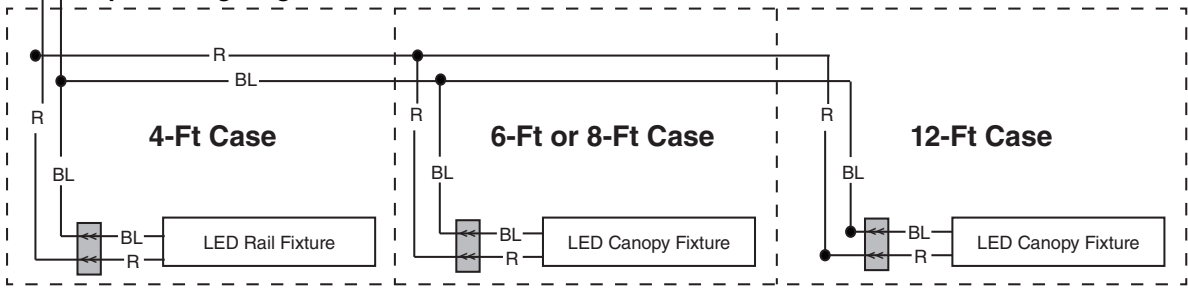

### WARNING

All components must have mechanical ground, and the merchandiser must be grounded.

R = Red   Y = Yellow   G = Green   BL = Blue   BK = Black   W = White  
 ● = 120V POWER   ○ = 120V NEUTRAL   ⚡ = FIELD GROUND   ⏏ = CASE GROUND

**Optional Shelf Lighting—LED Fixtures**

**Optional Shelf Harness and LED Light Circuits for 4 or 5 Rows of Shelves**

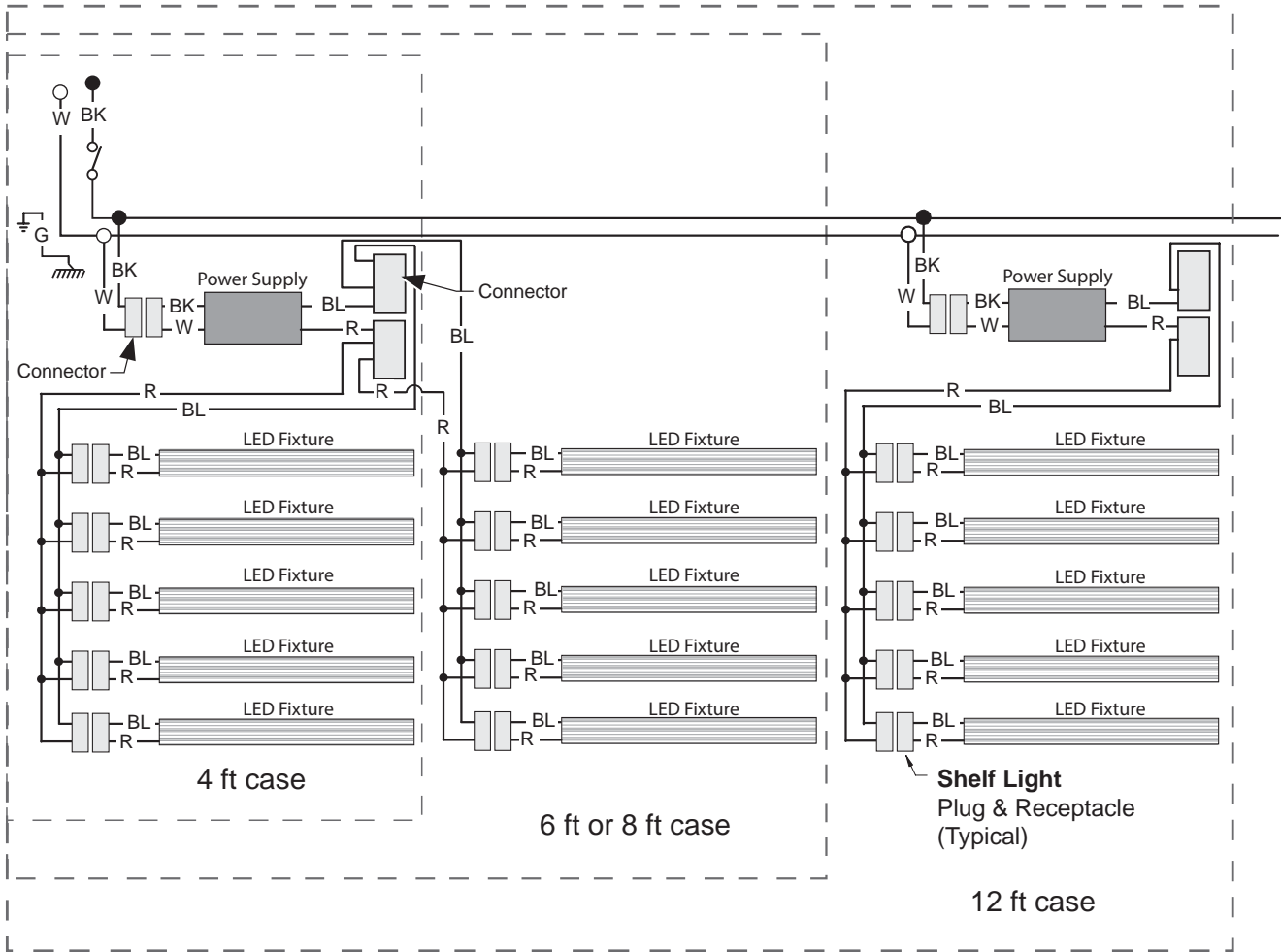

**WARNING**

All components must have mechanical ground, and the merchandiser must be grounded.

R = Red    Y = Yellow    G = Green    BL = Blue    BK = Black    W = White  
 ● = 120V POWER    ○ = 120V NEUTRAL    ⊥ = FIELD GROUND    ≡ = CASE GROUND

**Optional Shelf Lighting—LED Fixtures**

**Optional Shelf Harness and LED Light Circuits for 6 or 7 Rows of Shelves**

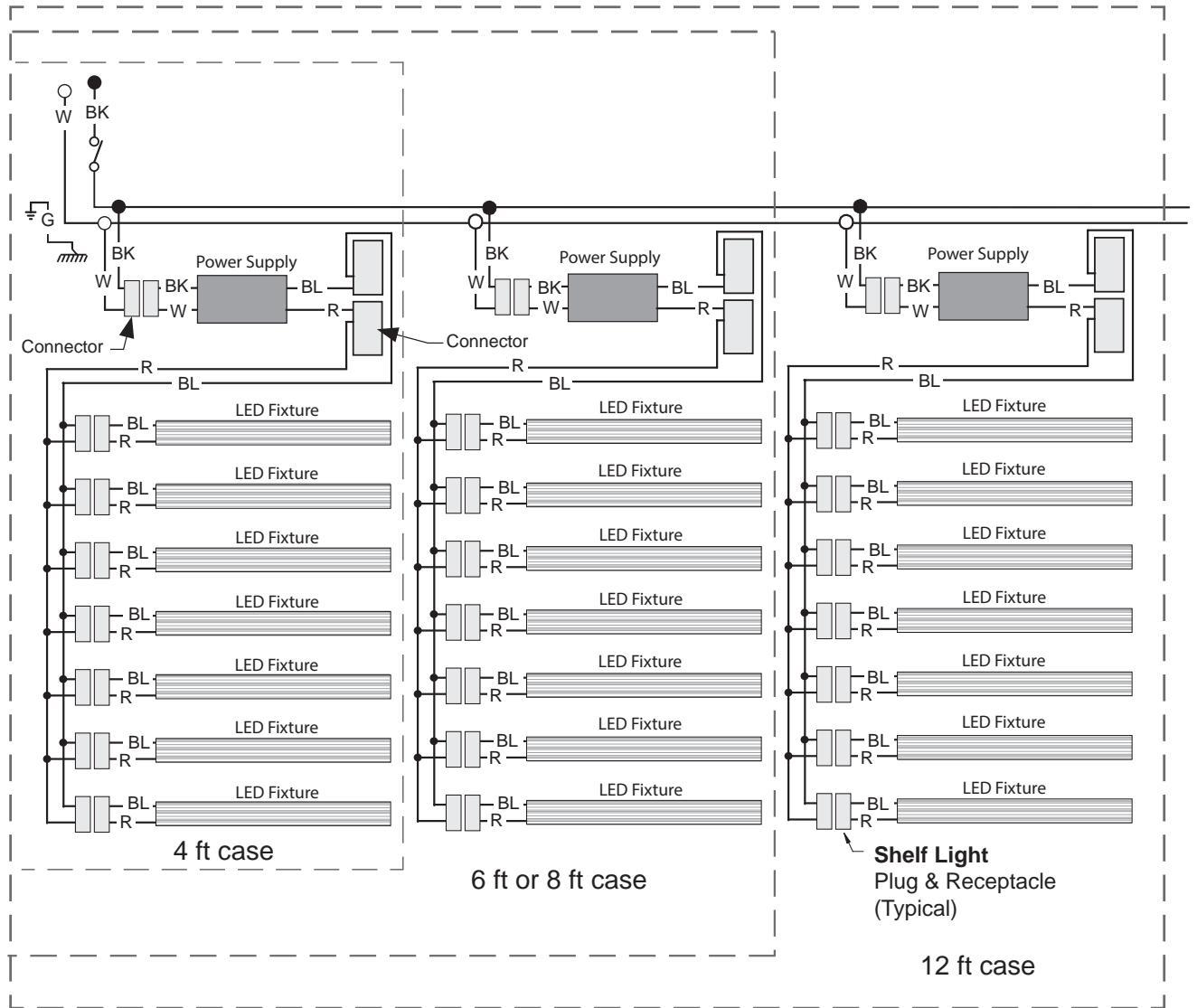

**WARNING**

All components must have mechanical ground, and the merchandiser must be grounded.

R = Red    Y = Yellow    G = Green    BL = Blue    BK = Black    W = White  
 ● = 120V POWER    ○ = 120V NEUTRAL    ⊥ = FIELD GROUND    ≡ = CASE GROUND

**Insight IDF6NU**  
**Dairy / Delicatessen /**  
**Meat**

**Estimating Refrigeration and Electrical Load (for comparison purposes only)**

**Case Btu**

To determine Btu for a case, refer to the performance data chart on page 2. Select lit or unlit shelves, then select the type of remote refrigeration system (parallel or conventional), which will give Btu/hr/ft. Multiply this number by the length of the case to determine Btu per hour.

**Case Electrical**

Refer to store legend to determine number of circuits. Lighting should be specified in store legend.

Fan electrical load for a case is computed by selecting the case length and fan voltage on page 6. For example, a 12 ft case uses 3 fans. The store legend specifies fans on a 230V circuit. In this instance, fans use 0.62 Amps and the MCA is 0.82. When applied, ambient fans, anti-sweat heaters, controllers, etc. must be included in the MCA. Include lights in the MCA if lights are on same circuit.

Lights may be on a separate circuit. To estimate lighting load: select case length (12 ft), canopy lighting [standard or optional] (here 0.70 for standard), and shelf or rail lighting [maximum for which case is wired] (1.73 for seven shelves); then add together  $[0.48 + 1.73 = 2.21$  amps for 120V] (for 230V, multiply  $2.21 * 0.52 = 1.15$ ).

**Line Sizing — Refer to store legend.**

Hussmann Line Sizing Charts are engineered for use with Hussmann refrigeration equipment.

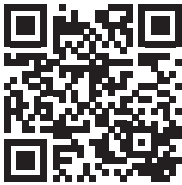

Scan the QR code with your mobile device to access additional product information or order parts.

Parts may also be ordered at:

**[parts.hussmann.com](https://parts.hussmann.com)**

**Call toll free: 1.855.487.7778**

---

**Revision History**

Revision A: April 2022: Original Issue

Revision B: July 2022. Added notes for Extended Drain Kit Option.