



SELF-SERVICE DELI
HUSSMANN - Q2-SSM-S

REVISION DATE

03/11/20



Hussmann refrigerated merchandisers configured for sale for use in the United States meet or surpass the requirements of the DOE 2017 energy efficiency standards.

Q2-SS-S

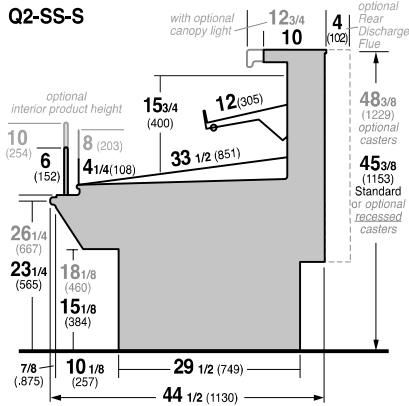

Q2-SS-S, Q3-SS-S
Self Service Self-Contained

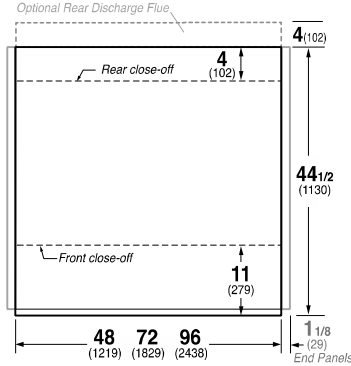

REFRIGERATION DATA:

CASE LENGTHS	CASE USAGE	CONVENTIONAL CAPACITY ** (BTU/HR/FT)	DISCHARGE AIR * (°F)	VELOCITY (FT/MIN)
3',4',6',8'	SS DELI	830	26-32	150-200

*FRONT DISCHARGE AIR MEASURED INSIDE AIR CURTAIN HONEYCOMB

**REFRIGERATION NOTES:

- 1) CAPACITY FOR REFERENCE ONLY
- 2) USE DEW POINT FOR HIGH GLIDE REFRIGERANTS. CARE SHOULD BE TAKEN TO USE THE DEW POINT IN P/T TABLES FOR MEASURING AND ADJUSTING SUPERHEAT.
- 3) RATING CONDITION IS NSF TYPE I, 75°F/55% RH

REFRIGERATION DATA CONTINUED:

CONTROLLER / AIR SENSOR SETTINGS			DEFROST TYPE	FAILSAFE TIME (MIN)	DEFROST FREQUENCY (#/DAY)	TERM. TEMP (°F) AIR	DRIP TIME (MIN)	DEFROST WATER (LBS/DAY/FT)
USAGE	SET POINT (°F)	DIFFERENTIAL (°F)						
DELI	24	8	OFF TIME	50	4	48	NA	4.2
MEAT	20	8						

END PANEL WIDTH KEY		
# OF END PNLS	END PNL WIDTH (IN.)	TOTAL ADDED LENGTH (IN.)
1	1.125	1.125
2	1.125	2.25

ELECTRICAL DATA:

STANDARD FANS, HEATERS, LED LIGHTS (115 VOLT)

CASE LENGTH	EVAPORATOR FANS					CANOPY LIGHTS LED		OPTIONAL LED SHELF LIGHTS		MAX. LED LOAD (W/ ALL OPTIONS)		ANTI-SWEAT HEATERS		CONVENIENCE OUTLETS (OPTIONAL)		
	# OF EVAP FANS	BLADE DIA. (IN.)	BLADE PITCH (°)	AMPS	WATTS	AMPS	WATTS	AMPS	WATTS	AMPS	WATTS	AMPS	WATTS	# OUTLETS	VOLTS	AMPS
3'	2	6.7	15	0.24	16	0.1	8	0.13	15	0.2	23	N/A	N/A	N/A	N/A	N/A
4'	2	6.7	15	0.24	16	0.1	10	0.18	21	0.3	31	N/A	N/A	N/A	N/A	N/A
6'	3	6.7	25	0.36	24	0.1	15	0.13	15	0.3	31	N/A	N/A	N/A	N/A	N/A
8'	4	6.7	20	0.48	32	0.2	21	0.18	21	0.4	41	N/A	N/A	N/A	N/A	N/A

CONDENSING UNIT AND EVAPORATIVE PANS

CASE LENGTH	CONDENSING UNIT				EVAPORATIVE PAN			EST. REFG. CHR.G. (LBS)	NEMA PLUG	
	NOM. HP	REFRIG.	Hz/Ph	VOLTS	RLA	VOLTS	AMPS			WATTS
3'	1/2	R-404A	60 / 1	115	9.2	115	8.3	1000	2.5	L5-30P
4'	1/2		60 / 1	115	10.5	115	8.3	1000	3.7	L5-30P
6'	3/4		60 / 1	240	9.0	240	6.3	1500	5.6	L14-30P
8'	1		60 / 1	240	10.0	240	6.3	1500	6.6	L14-30P
3'	1/3	R-448A	60 / 1	115	7.2	115	8.3	1000	2.5	L5-30P
4'	1/2		60 / 1	115	10.0	115	8.3	1000	2.2	L5-30P
6'	3/4		60 / 1	240	9.0	240	6.3	1500	3.0	L14-30P
8'	1		60 / 1	240	10.0	240	6.3	1500	3.7	L14-30P

OPTIONAL HIGH OUTPUT LED LIGHTS (115 VOLT)

CASE LENGTH	CANOPY LIGHTS H.O. LED		OPTIONAL SHELF		MAX. H.O. LED LOAD	
	AMPS	WATTS	AMPS	WATTS	AMPS	WATTS
3'	0.1	13	0.3	34	0.4	47
4'	0.1	15	0.4	41	0.5	56
6'	0.4	47	0.5	63	1.0	110
8'	0.3	30	0.4	51	0.7	81