

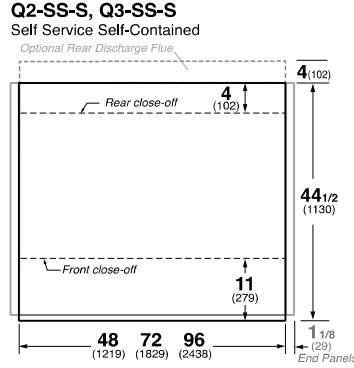

Hussmann refrigerated merchandisers configured for sale for use in the United States meet or surpass the requirements of the DOE 2017 energy efficiency standards.

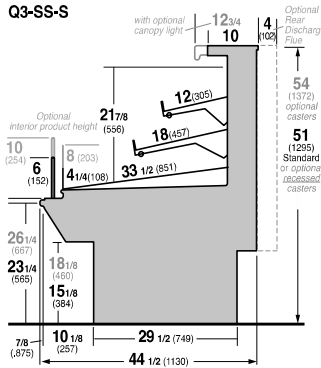
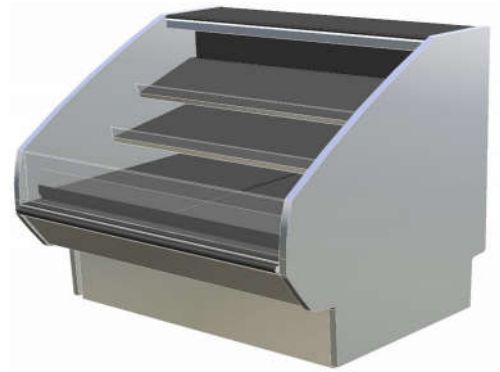

REFRIGERATION DATA:

CASE LENGTHS	CASE USAGE	CONVENTIONAL CAPACITY ** (BTU/HR/FT)	DISCHARGE AIR * (°F) (SEE SETPOINTS BELOW)	VELOCITY (FT/MIN)
3',4',5',6',8'	SS DELI	1040	22~26	150~200

*FRONT DISCHARGE AIR MEASURED INSIDE AIR CURTAIN HONEYCOMB

**REFRIGERATION NOTES:

- 1) CAPACITY FOR REFERENCE ONLY
- 2) USE DEW POINT FOR HIGH GLIDE REFRIGERANTS. CARE SHOULD BE TAKEN TO USE THE DEW POINT IN P/T TABLES FOR MEASURING AND ADJUSTING SUPERHEAT.
- 3) RATING CONDITION IS NSF TYPE I, 75°F/55% RH

REFRIGERATION DATA CONTINUED:

CONTROLLER / AIR SENSOR SETTINGS			DEFROST TYPE	FAILSAFE TIME (MIN)	DEFROST FREQUENCY (#/DAY)	TERM. TEMP (°F) AIR	DRIP TIME (MIN)	DEFROST WATER (LBS/DAY/FT)
USAGE	SET POINT (°F)	DIFFERENTIAL (°F)						
MEAT	20	8	OFF TIME	50	4	48	NA	4.2
DELI	24	8						
PRODUCE	28	8						

END PANEL WIDTH KEY		
# OF END PNLS	END PNL WIDTH (IN.)	TOTAL ADDED LENGTH (IN.)
1	1.125	1.125
2	1.125	2.25

ELECTRICAL DATA:

STANDARD FANS, HEATERS, LED LIGHTS (115 VOLT)

CASE LENGTH	EVAPORATOR FANS					CANOPY LIGHTS LED		OPTIONAL LED SHELF LIGHTS		MAX. LED LOAD (W/ ALL OPTIONS)		ANTI-SWEAT HEATERS (OPTIONAL)		CONVENIENCE OUTLETS (OPTIONAL)		
	# OF EVAP FANS	BLADE DIA. (IN.)	BLADE PITCH (°)	AMPS	WATTS	AMPS	WATTS	AMPS	WATTS	AMPS	WATTS	AMPS	WATTS	# OUTLETS	VOLTS	AMPS
3'	2	6.7	25	0.24	16	0.17	19	0.13	15	0.30	35	N/A	N/A	N/A	N/A	N/A
4'	2	6.7	25	0.24	16	0.23	27	0.18	21	0.41	48	N/A	N/A	N/A	N/A	N/A
5'	2	6.7	20	0.24	16	0.30	34	0.23	26	0.52	60	N/A	N/A	N/A	N/A	N/A
6'	3	6.7	25	0.36	24	0.34	39	0.27	31	0.60	69	N/A	N/A	N/A	N/A	N/A
8'	4	6.7	25	0.48	32	0.47	54	0.36	41	0.83	95	N/A	N/A	N/A	N/A	N/A

CONDENSING UNIT AND EVAPORATIVE PANS

CASE LENGTH	CONDENSING UNIT					EVAPORATIVE PAN		NEMA PLUG	EST. REFG. CHR.G. (LBS)
	NOM. HP	REFRIG.	Hz/Ph	VOLTS	RLA	AMPS	WATTS		
3'	1/3	R-404A	60 / 1	115	7.2	8.3	1000	L5-30P	3.3
4'	1/2		60 / 1	115	10.5	12.5	1500	L5-30P	3.7
5'	3/4		60 / 1	240	6.8	6.3	1500	L6-20P	5.6
6'	3/4		60 / 1	240	9.0	6.3	1500	L14-30P	5.6
8'	1		60 / 1	240	10.0	6.3	1500	L14-30P	6.6
3'	TBD	R-448A	TBD	TBD	TBD	TBD	TBD	TBD	TBD
4'	1/2		60 / 1	115	10.5	12.5	1500	L5-30P	3.7
5'	3/4		60 / 1	240	9.0	6.3	1500	L6-20P	2.8
6'	3/4		60 / 1	240	9.0	6.3	1500	L14-30P	3.0
8'	1-3/4		60 / 1	240	10.0	6.3	1500	L14-30P	3.7

OPTIONAL HIGH OUTPUT LED LIGHTS (115 VOLT)

CASE LENGTH	CANOPY LIGHTS H.O. LED		OPTIONAL SHELF		MAX. H.O. LED LOAD	
	AMPS	WATTS	AMPS	WATTS	AMPS	WATTS
3'	0.21	24	0.32	36	0.52	60
4'	0.28	32	0.35	41	0.63	73
5'	N/A	N/A	N/A	N/A	N/A	N/A
6'	0.41	47	0.29	34	0.70	81
8'	0.56	64	0.44	51	1.00	115