

**HUSSMANN**<sup>®</sup>/Chino

**RFED**

UPRIGHT FROZEN FOOD CASE

Installation  
& Operation  
Manual

REV.0003



**HUSSMANN**<sup>®</sup>

**RFED**

UPRIGHT FROZEN FOOD CASE

P/N IGUF-RFED-0003

**INSTALLATION & OPERATION GUIDE**

## General Instructions

### Table of Contents

<b>General Instructions</b> .....	<b>2</b>
<b>Cut &amp; Plan Views</b> .....	<b>3</b>
<b>Installation</b> .....	<b>3</b>
LEVELING .....	4
JOINT TRIM .....	4
<b>Plumbing</b> .....	<b>5</b>
WASTE OUTLET AND P-TRAP .....	5
<b>Refrigeration</b> .....	<b>5</b>
<b>Mechanical Locations</b> .....	<b>6</b>
T-STAT LOCATION .....	6
<b>Electrical</b> .....	<b>7</b>
WIRING COLOR CODE .....	7
ASHRAE COLOR CODE .....	7
<b>User Information</b> .....	<b>8</b>
STOCKING .....	8
CASE CLEANING .....	8
PLEXIGLASS & ACRYLIC CARE .....	9
<b>Maintenance</b> .....	<b>9</b>
ELECTRICAL PRECAUTIONS .....	9
REPLACING FLUORESCENT LAMPS .....	9
TIPS & TROUBLESHOOTING .....	9
<b>Electrical and Refrigeration Specifications</b> .....	<b>10</b>
<b>Electrical Schematics</b> .....	<b>11</b>
<b>Appendices</b> .....	<b>12</b>
APPENDIX A. – Temperature Guidelines .....	12
APPENDIX B. – Application Recommendations .....	12
APPENDIX C. – Field Recommendations - .....	12
APPENDIX D. – Recommendations to user - .....	13

### THIS BOOKLET CONTAINS INFORMATION ON:

*RFED Straight-glass refrigerated service meat/fish merchandiser*

#### SHIPPING DAMAGE

All equipment should be thoroughly examined for shipping damage before and during unloading.

This equipment has been carefully inspected at our factory and the carrier has assumed responsibility for safe arrival. If damaged, either apparent or concealed, claim must be made to the carrier.

#### APPARENT LOSS OR DAMAGE

If there is an *obvious loss or damage*, it must be noted on the freight bill or express receipt and signed by the carrier's agent; otherwise, carrier may refuse claim. The carrier will supply necessary claim forms.

#### CONCEALED LOSS OR DAMAGE

When loss or damage is *not apparent until after equipment is uncrated*, a claim for concealed damage is made. Make request in writing to carrier for inspection within 15 days, and retain all packaging. The carrier will supply inspection report and required claim forms.

#### SHORTAGES

Check your shipment for any possible shortages of material. If a shortage should exist and is found to be the responsibility of Hussmann Chino, *notify Hussmann Chino*. If such a shortage involves the carrier, *notify the carrier immediately*, and request an inspection. Hussmann Chino will acknowledge shortages within ten days from receipt of equipment.

#### HUSSMANN CHINO PRODUCT CONTROL

The serial number and shipping date of all equipment has been recorded in Hussmann's files for warranty and replacement part purposes. All correspondence pertaining to warranty or parts ordering must include the serial number of each piece of equipment involved, in order to provide the customer with the correct parts.

***The Hussmann warranty is printed on the back of this guide.***

Keep this booklet with the case at all times for future reference.

## HUSSMANN®/Chino

A publication of  
Hussmann® Chino  
13770 Ramona Avenue • Chino, California 91710  
(909) 628-8942 FAX  
(909) 590-4910  
(800) 395-9229

**Cut & Plan Views**

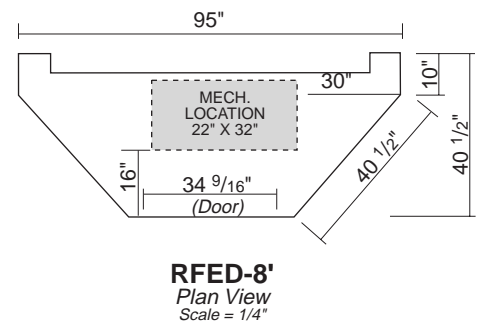
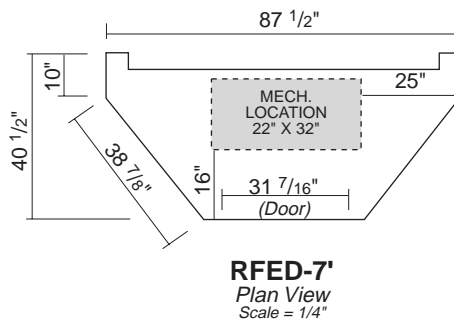
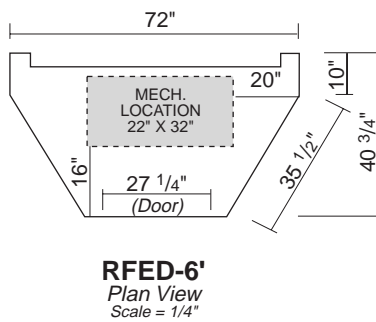
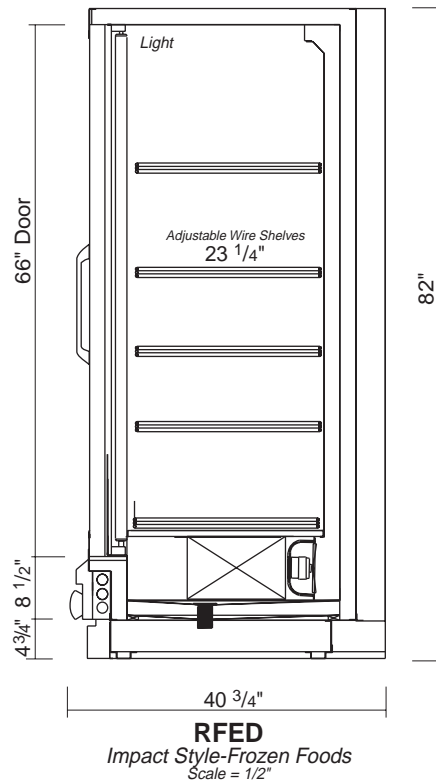

**Installation**

**LOCATION**

The refrigerated merchandisers have been designed for use only in air conditioned stores where temperature and humidity are maintained at or below 75°F and 55% relative humidity. **DO NOT** allow air conditioning, electric fans, ovens, open doors or windows (etc.) to create air currents around the merchandiser, as this will impair its correct operation.

Product temperature should always be maintained at a constant and proper temperature. This means that from the time the product is received, through storage, preparation and display, the temperature of the product must

be controlled to maximize life of the product.

**UNCRATING THE STAND**

Place the fixture as close to its permanent position as possible. Remove the top of the crate. Detach the walls from each other and remove from the skid. Unbolt the case from the skid. The fixture can now be lifted off the crate skid. **Lift only at base of stand!**

**SETTING AND JOINING**

The case can stand by itself or may be attached to adjacent reach in cases as a crown case. The case should be brought up tight to adjoining cases. Rails on the back al-

### Installation (cont.)

low for ventilation. The sides of the RFED will but up to adjacent cases in the rear.

#### LEVELING

**IMPORTANT! IT IS IMPERATIVE THAT CASES BE LEVELED FROM FRONT TO BACK AND SIDE TO SIDE PRIOR TO JOINING. A LEVEL CASE IS NECESSARY TO INSURE PROPER OPERATION, WATER DRAINAGE, GLASS ALIGNMENT, AND OPERATION OF THE HINGES SUPPORTING THE GLASS. LEVELING THE CASE CORRECTLY WILL SOLVE MOST HINGE OPERATION PROBLEMS.**

**NOTE:** A. To avoid removing concrete flooring, begin lineup leveling from the highest point of the store floor.

B. When wedges are involved in a lineup, set them first.

All cases were leveled and joined prior to shipment to insure the closest possible fit when cases are joined in the field. When joining, use a carpenter's level and shim legs accordingly. Case must be raised correctly, under legs where support is best, to prevent damage to case.

1. Check the floor pitch where the cases are to be set. Determine the highest point of the floor; cases will be set off this point.
2. Set first case, and adjust legs over the highest part of the floor so that case is level. Prevent damage – case must be raised under leg or by use of 2x6 or 2x4 leg brace. Remove side and back leg braces after case is set.
3. Set second case as close as possible to the first case, and level case to the first using the instructions in step one.
4. Apply masking tape 1/8" in from end of case on inside and outside rear mullion on both cases to be joined.
5. Apply liberal bead of case joint sealant (butyl) to dotted area shown in (Fig.2, #1) of first case. Apply heavy amount to cover entire shaded area.

**DO NOT USE PERMAGUM!**

6. Slide second case up to first case snugly. Then level second case to the first case so glass front, bumper and top are flush.
7. To compress butyl at joint, use two Jurgenson wood clamps. Make sure case is level from front to back and side to side on inside bulkheads at joint.
8. Attach sections together via a 2 bolts located in the base of the case. Secure the overhead structure by bolting the bracket, located inside behind lights.



**CAUTION**

**Do not use cam locks to pull cases together.**

9. Apply bead of butyl to top of bulkheads and slip on stainless steel bulkhead cap. Also apply butyl to seam between overhead light tubes.
10. **VERY IMPORTANT!** Apply liberal amounts of black butyl to area under interior lower legs and fill all voids down to bulkhead, if applicable.
11. Use finger to smooth butyl as thin as possible at masking tape on inside and outside of rear mullion (apply additional butyl if necessary). Remove tape applied on line #3.

#### JOINT TRIM

After cases have been leveled and joined, and refrigeration, electrical, and wasted piping work completed, install the splashguards. Fasten along the top edge, or center, with #10 X 3/3" sheet metal screws.

**DO NOT SEAL JOINT TRIM TO FLOOR!**



**ATTENTION  
INSTALLER**

**It is the contractor's responsibility to install case(s) according to local construction and health codes.**

## Plumbing

### WASTE OUTLET AND P-TRAP

The waste outlet is located off the center of the case on one side allowing drip piping to be run lengthwise under the fixture.

A 1-1/2" P-trap and threaded adapter are supplied with each fixture. The P-trap must be installed to prevent air leakage and insect entrance into the fixture.

**NOTE:** PVC-DWV solvent cement is recommended.  
Follow the manufacturer's instructions.

### INSTALLING CONDENSATE DRAIN

Poorly or improperly installed condensate drains can seriously interfere with the operation of this refrigerator, and result in costly maintenance and product losses. Please follow the recommendations listed below when installing condensate drains to insure a proper installation:

1. Never use pipe for condensate drains smaller than the nominal diameter of the pipe or P-trap supplied with the case.
2. When connecting condensate drains, the P-trap must be used as part of the condensate drain to prevent air leakage or insect entrance. Store plumbing system floor drains should be at least 14" off the center of the case to allow use of the P-trap

pipe section. Never use two water seals in series in any one line. Double P-traps in series will cause a lock and prevent draining.

3. Always provide as much down hill slope ("fall") as possible; 1/8" per foot is the preferred minimum. PVC pipe, when used, must be supported to maintain the 1/8" pitch and to prevent warping.
4. Avoid long runs of condensate drains. Long runs make it impossible to provide the "fall" necessary for good drainage.
5. Provide a suitable air break between the flood rim of the floor drain and outlet of condensate drain. 1" is ideal.
6. Prevent condensate drains from freezing:
  - a. Do not install condensate drains in contact with non-insulated suction lines. Suction lines should be insulated with a nonabsorbent insulation material such as Armstrong's Armaflex.
  - b. Where condensate drains are located in dead air spaces (between refrigerators or between a refrigerator and a wall), provide means to prevent freezing. The water seal should be insulated to prevent condensation.

## Refrigeration

### REFRIGERANT TYPE

The standard refrigerant will be R-22 unless otherwise specified on the customer order. Check the serial plate on the case for information.

### PIPING

The refrigerant line outlets are located under the case. Locate first the electrical box, the outlets are then on the same side of the case but at the opposite end. Insulate suction lines to prevent condensation drippage.

### REFRIGERATION LINES

LIQUID	SUCTION
3/8" O.D.	5/8" O.D.

**NOTE:** The standard coil is piped at 5/8" (suction); however, the store tie-in may vary depending on the number of coils and the draw the case has. Depending on the case setup, the connecting point in the store may be 5/8", 7/8", or 1 1/8". Refer to the particular case you are hooking up.

Refrigerant lines should be sized as shown on the refrigeration legend furnished by the store.

Install P-traps (oil traps) at the base of all suction line vertical risers.

Pressure drop can rob the system of capacity. To keep the pressure drop to a minimum, keep refrigerant line run as short as possible, using the minimum number of elbows.

Where elbows are required, use long radius elbows only.

### CONTROL SETTINGS

See the "Case Specs" section of this guidebook for the appropriate settings for your merchandiser. Maintain these parameters to achieve near constant product temperatures. Product temperature should be measured first thing in the morning, after having been refrigerated overnight. For all multiplexing, defrost should be time terminated. Loadmaster valves are not recommended. Defrost times should as directed in the Case Specifications section of this guide. The number of defrosts per day should never change. The duration of the defrost cycle may be adjusted to meet conditions present at your location.

### ACCESS TO TX VALVES & DRAIN LINES

**MECHANICAL** - Remove product from end of case. Remove product racks. Remove refrigeration and drain access panels (labeled). TX valve (mechanical only) and drain are located under each access panel at end of the case.

**ELECTRONIC** - The Electronic Expansion valve master and slave cylinder(s) are located within the electrical access panel(s).

### ELECTRONIC EXPANSION VALVE (OPTIONAL)

A wide variety of electronic expansion valves and case controllers can be utilized. Please refer to EEV and con-

**Refrigeration (Continued)**

troller manufacturers information sheet. Sensors for electronic expansion valves will be installed on the coil inlet, coil outlet, and in the discharge air. (Some supermarkets require a 4th sensor in the return air). Case controllers will be located in the electrical raceway or under the case

**THERMOSTATIC EXPANSION VALVE LOCATION**

This device is located on the same side as the refrigeration stub. A Sporlan balanced port expansion valve model is furnished as standard equipment, unless otherwise specified by customer.

**EXPANSION VALVE ADJUSTMENT**

Expansion valves must be adjusted to fully feed the evaporator. Before attempting any adjustments, make sure the evaporator is either clear or very lightly covered with frost, and that the fixture is within 10°F of its expected operating temperature.

**MEASURING THE OPERATING SUPERHEAT**

1. Determine the suction pressure with an accurate pressure gauge at the evaporator outlet.
2. From a refrigerant pressure temperature chart, determine the saturation temperature at the observed suction pressure.
3. Measure the temperature of the suction gas at the thermostatic remote bulb location.
4. Subtract the saturation temperature obtained in step No.2 from the temperature measured in step No.3.
3. The difference is superheat.
5. Set the superheat for 5°F - 7°F.





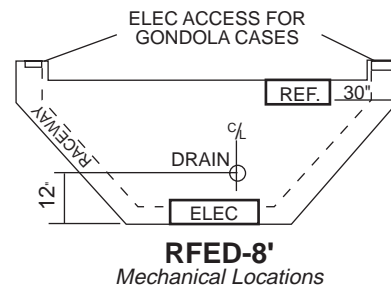
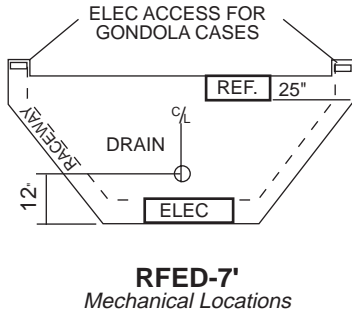
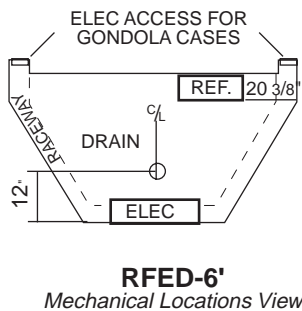
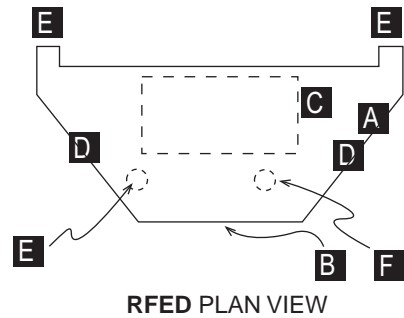
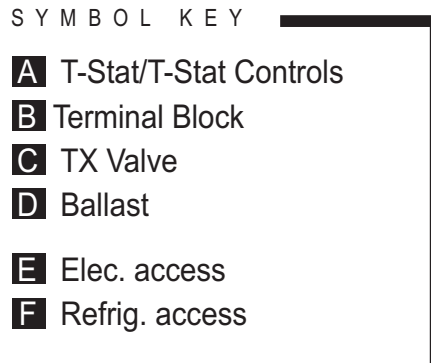
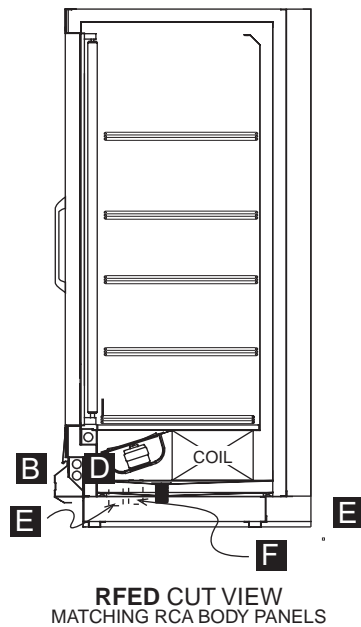

**T-STAT LOCATION**

T-Stats are located within the electrical raceway. Refer to diagram below.

**Mechanical Locations**



**WIRING COLOR CODE**

STANDARD CASE WIRE COLOR CODE CODIGO DE COLORES DE LOS ALAMBRES PARA LAS VITRINAS ESTANDAR CODE COULEUR POUR FILS DE BOITIER NORMALISE			
Color	Description	Description	Description
<input type="checkbox"/> 	GROUND	TIERRA MASA	MASSE
<input type="checkbox"/> 	ANTI-SWEAT	ANTICONDENSACION	ANTI-SUINTEMENT
<input type="checkbox"/> 	LIGHTS	LUCES	ECLAIRAGE
<input type="checkbox"/> 	RECEPTACLES	ENCHUFER	RECEPTACLE
<input type="checkbox"/> 	T-STAT/SOLENOID 230 V	THERMOSTATO / SOLENOID (230 VAC)	SOUPAPE A SOLENOID (230 V)
<input type="checkbox"/> 	T-STAT/SOLENOID 115 V	THERMOSTATO / SOLENOID (115 VAC)	SOUPAPE A SOLENOID (115 V)
<input type="checkbox"/> 	FAN MOTORS	VENTILADORES	VENTILATEUR

430-01-0338 r9908

**CASE MUST BE GROUNDED**

NOTE: Refer to label affixed to case to determine the actual configuration as checked in the "TYPE INSTALLED" boxes.

**ELECTRICAL CIRCUIT IDENTIFICATION**

Standard lighting for all models will be full length fluorescent lamps located within the case at the top. The switch controlling the lights, the plug provided for digital scale, and the thermometer are located at the rear of the case mullion.

The receptacle that is provided on the exterior back of these models is intended for computerized scales with a five amp maximum load, not for large motors or other high wattage appliances. It should be wired to a dedicated circuit.

**ELECTRICAL SERVICE RECEPTACLES (WHEN APPLICABLE)**

The receptacles located on the exterior of the merchandiser are intended for scales and lighted displays. They are not intended nor suitable for large motors or other external appliances.



**BEFORE SERVICING  
ALWAYS DISCONNECT ELECTRICAL  
POWER AT THE MAIN DISCONNECT  
WHEN SERVICING OR REPLACING ANY  
ELECTRICAL COMPONENT.  
This includes (but not limited to) Fans, Heat-  
ers, Thermostats, and Lights.**

**FIELDWIRING & SERIAL PLATE AMPERAGE**

Field Wiring must be sized for component amperes printed on the serial plate. Actual ampere draw may be less than specified. Field wiring from the refrigeration control panel to the merchandisers is required for refrigeration thermostats. Most component amperes are listed in the "Case Specs" section, but always check the serial plate.

**BALLAST LOCATION**

Ballasts are located within the access panel that runs the length of the rear of the case. Refer to diagram on page 6.

**WIRING & SERIAL PLATE AMPERAGE**

Field Wiring must be sized for component amperes stamped on the serial plate. Actual ampere draw may be less than specified. Field wiring from the refrigeration control panel to the merchandisers is required for refrigeration thermostats. Most component amperes are listed in the "Case Specs" section, but always check the serial plate.

**ASHRAE COLOR CODE**

NOTE: All other manufacturers; no known sensor codes

Case Control Systems SENSOR COLORS			
Manufacturer @ >	EIL	CPC	
Location			
Coil Inlet	Color	Blue	Blue
	Part#	225-01-1755	225-01-3255
Coil Outlet	Color	Red	Red
	Part#	225-01-1757	225-01-3123
Discharge Air	Color	Green	Green
	Part#	225-01-1756	225-01-3260
Return Air	Color	Purple	Green
	Part#	225-01-1758	225-01-3260
Defrost Term.	Color	White	Orange
	Part#	225-01-0650	225-01-3254
Liquid Line	Color	White	Blue
	Part#	225-01-0650	225-01-3255



## User Information

### STOCKING

Improper temperature and lighting will cause serious product loss. Discoloration, dehydration and spoilage can be controlled with proper use of the equipment and handling of product. Product temperature should always be maintained at a constant and proper temperature. This means that from the time the product is received, through storage, preparation and display, the temperature of the product must be controlled to maximize life of the product. Hussmann cases were not designed to “heat up” or “cool down” product—but rather to maintain an item’s proper temperature for maximum shelf life. To achieve the protection required always:

1. Minimize processing time to avoid damaging temperature rise to the product. Product should be at proper temperature.
2. Keep the air in and around the case area free of foreign gasses and fumes or food will rapidly deteriorate.
3. Maintain the display merchandisers temperature controls as outlined in the refrigerator section of this manual.
4. Do not place any product into these refrigerators until all controls have been adjusted and they are operating at the proper temperature. Allow merchandiser to operate a minimum of 6 hours before stocking with any product.
5. When stocking, never allow the product to extend beyond the recommended load limit. **Air discharge and return air flue must be unobstructed at all times to provide proper refrigeration.**
6. There are vents located at the base of the front of the glass, just above the front rail. These vents supply a continuous, gentle flow of air across the front glass which inhibits condensation. **Do not place any signs or other restrictive objects on the front of the refrigerator that will block these vents.**
7. Keep the doors closed (when applicable). Refrigeration performance will be seriously affected if left open for a prolonged period of time.
8. Avoid the use of supplemental flood or spot lighting. Display light intensity has been designed for maximum visibility and product life at the factory. The use of higher output fluorescent lamps (H.O. and V.H.O.), will shorten the shelf life of the product.

### CASE CLEANING

Long life and satisfactory performance of any equipment are dependent upon the care given to it. To insure long life, proper sanitation and minimum maintenance costs, the refrigerator should be thoroughly cleaned frequently. **SHUT OFF FAN DURING CLEANING PROCESS.** It can be unplugged within the case, or shut off case at the source. The interior bottom may be cleaned with any domestic soap or detergent based cleaners. Sanitizing solutions will not harm the interior bottom, however, these solutions should always be used according to the manufacturer’s directions. It is essential to establish and regulate cleaning procedures. This will minimize bacteria causing discoloration which leads to degraded product appearance and significantly shortening product shelf life.

*Soap and hot water are not enough to kill this bacteria. A sanitizing solution must be included with each cleaning process to eliminate this bacteria.*

1. Scrub thoroughly, cleaning all surfaces, with soap and hot water.
2. Rinse with hot water, but do not flood.
3. Apply the sanitizing solution according to the manufacturer’s directions.
4. Rinse thoroughly.
5. Dry completely before resuming operation.

### CLEANING GLASS & MIRRORS

Only use a soft cloth and mild glass cleaner for cleaning any glass or mirrored components. Be sure to rinse and/or dry completely.

**Never use hot water on cold glass surfaces! It may shatter and cause serious injury!** Allow glass surfaces to warm first



#### PRECAUTION

#### CLEANING PRECAUTIONS

##### WHEN CLEANING:

- DO NOT USE HIGH PRESSURE WATER HOSES
- DO NOT INTRODUCE WATER FASTER THAN WASTE OUTLET CAN DRAIN
- NEVER ON A SELF CONTAINED UNIT WITH AN EVAPORATOR FAN
- NEVER USE A CLEANING OR SANITIZING SOLUTION THAT HAS AN OIL BASE (these will dissolve the butyl sealants) or an AMMONIA BASE (this will corrode the copper components of the case)

##### TO PRESERVE THE ATTRACTIVE FINISH:

- DO USE WATER AND A MILD DETERGENT FOR THE EXTERIOR ONLY
- DO NOT USE ABRASIVES OR STEEL WOOL SCOURING PADS (these will mar the finish)



**User Information (Continued)**

**PLEXIGLASS & ACRYLIC CARE**

Improper cleaning not only accelerates the cleaning cycle but also degrades the quality of this surface. Normal daily buffing motions can generate static cling attracting dust to the surface. Incorrect cleaning agents or cleaning cloths can cause micro scratching of the surface, causing the plastic to haze over time.

**CLEANING**

Hussmann recommends using a clean damp chamois, or a paper towel marketed as dust and abrasive free with **210®**

**Plastic Cleaner and Polish** available by calling Sumner Labs at **1-800-542-8656**. Hard, rough cloths or paper towels will scratch the acrylic and should not be used.

**ANTISTATIC COATINGS**

The **210®** has proven to be very effective in not only cleaning and polishing the Plexiglass surface, but also providing anti-static and anti-fog capabilities. This product also seals pores and provides a protective coating.

**Maintenance**



**BEFORE SERVICING – Always disconnect electrical power at the main disconnect when servicing or replacing any electrical component**

This includes (but not limited to) Fans, Heaters, Thermostats, and Lights.

**REPLACING FLUORESCENT LAMPS**

Fluorescent lamps are furnished with a shatterproof protective coating. The same type of lamp with protective coating must be used if replaced.

This lamp has been treated to resist breakage and must be replaced with a similarly treated lamp in order to maintain compliance with NSF Standards. **NSF CODE 4.28.1**  
 Contact HUSSMANN Chino for replacement  
 1-800-395-9229 x 2131

**REPLACEMENT LAMP PART LIST**

Refrigerated Lamps

<b>Lamp</b>	Q150T3/CL	J220/230V150W/79
<b>Our Part No.</b>	125-03-1081	125-03-1141
<b>Voltage</b>	120VAC	220 VAC
<b>Rated Life</b>	1500 Hrs	1500 Hrs
<b>Manufacturer</b>	General electric	Ushio America, Inc.
<b>Our Cost</b>	\$7.00	\$2.55
<b>Telephone</b>	1-800-554-4680	1-800-760-7446 1-800-327-0097

General Electric has many national distribution locations. Call for your closest location.

Ushio America Inc. is located at: 10550 Camden Drive.  
Cypress, CA. 90630

**T-5 BULBS**

Cases are now wired with electronic ballasts that supply power to more than one bulb thus saving the customer equipment and energy costs. This configuration has proven to be very successful; however, there is a situation worth noting. As of the printing of this catalog, the ballasts for multiple T-5 bulbs are wired in series. Because of this, if

more than one shelf is run off one ballast, and one of the shelves is removed, the rest of the shelves will not light up. In order to operate the case lights without one of the shelves, a new ballast is required to supply power to the remaining shelves. In order to address this immediate situation, shelves are now wired horizontally through the lineup so that a whole tier can be removed yet allow the remaining tiers to stay lit.

**SAFETY NOTE:** Because of the different power requirements of T-5 lights, special ballasts are required that can maintain protection not only to the lamp but to the rest of the circuitry as well. The ballasts used for T-5 lighting are built with anti-arcing electronics that will shut off power to the lamp if arcing at the sockets or plugs is detected. It is designed for safety, preventing electrical fires. If power to a T5 bulb is interrupted, please check all connections at the sockets and plugs to verify the integrity of the circuit. **POWER MUST BE TURNED OFF, THEN ON AGAIN IN ORDER TO RESET THE BALLAST CIRCUITRY BEFORE LAMPS CAN BE RE-LIT.**

**EVAPORATOR FANS**

The evaporator fans are located at the center front of these merchandisers directly beneath the display pans. *Should fans or blades need servicing, always replace fan blades with the raised embossed side of the blade TOWARD THE MOTOR.*

**COPPER COILS**

The copper coils used in Hussmann merchandisers may be repaired in the field. Materials are available from local refrigeration wholesalers.

Hussmann recommends using #15 Sil-Fos for repairs.

**TIPS & TROUBLESHOOTING**

**Before calling for service, check the following:**

1. Check electrical power supply to the equipment for connection.
2. Check fixture loading. Overstocking case will affect its proper operation.
3. If frost is collecting on fixture and/or product, check

## Maintenance (Continued)

that Humidity Control is working properly, and that no outside doors or windows are open—allowing moisture to enter store.



### IMPORTANT INFORMATION

**FOR PROMPT SERVICE**  
When contacting the factory,  
be sure to have the Case Model and Serial  
Number handy. This information is on a plate  
located on the case itself.

## Electrical and Refrigeration Specifications

LENGTH	BTU REQ'D PER FT.	TEMPERATURE			DISCHG. AIR VELOC @FPM	T-STAT/ CUT IN SETTINGS	TYPE OF COIL	FAN SIZE & NUMBER OF MOTORS	DEFROST FREQ. & DURATION	115 V. ELECTRICAL CIRCUITS			208V DEFROST DRAIN HEATER	
		EVAP TMP	AVG PROD TMP	DISC TMP						STD. FANS	WARMERS	LIGHTS		
(E) = Electric Defrost(G) =Koolgas Defrost(O) = Off Cycle Defrost														
5'-9"	Frozen Food	6475	-15°	-5°	-5°	350	-5°	Forced Air	8"x50° (2)	40min(1) E 20min(1) G	3.0	1.7	7.8	13.9
	Ice Cream	7175 Total	-25°	-12°	-15°	350	-15°	Forced Air	8"x50° (2)	40min(1) E 20min(1) G	3.0	1.7	7.8	13.9
7'-2"	Frozen Food	6925	-15°	-5°	-5°	350	-5°	Forced Air	8"x50° (2)	40min(1) E 20min(1) G	3.0	13.4	7.8	15.1
	Ice Cream	7700 Total	-25°	-12°	-15°	350	-15°	Forced Air	8"x50° (2)	40min(1) E 20min(1) G	3.0	13.4	7.8	15.1
7'-9"	Frozen Food	7375	-15°	-5°	-5°	350	-5°	Forced Air	8"x50° (2)	40min(1) E 20min(1) G	3.0	13.4	7.8	15.1
	Ice Cream	8200 Total	-25°	-12°	-15°	350	-15°	Forced Air	8"x50° (2)	40min(1) E 20min(1) G	3.0	13.4	7.8	15.1

#### HUSSMANN CHINO CASE SPECIFICATIONS 12/99

**NOTES:** These merchandisers have been designed for use in stores where temperatures and humidity are maintained at or below 75°F and 55%RH. Stores are responsible for setting their cases appropriately in conditions which vary from the above. The number of defrosts and/or the duration may vary for cases displaying products for which they were not designed. Italicized data indicates optional equipment.

- Hussmann Chino reserves the right to change or revise case specifications and design in connection with any feature of our products without notice. Such changes do not entitle the buyer to corresponding changes, improvements, additions, or replacement of equipment previously sold or shipped. These changes may also affect the loads applicable to a particular case, therefore always check the serial plate at the back of the case and/or consult the factory for the current loads for your particular equipment.

*INQUIRIES? Technical (800) 395-9229 X2133 (Electrical) X2126 (Refrigeration) Service (800) 395-2320 Parts and Warranty Information (800) 395-9229 X2131*

Electrical Schematics

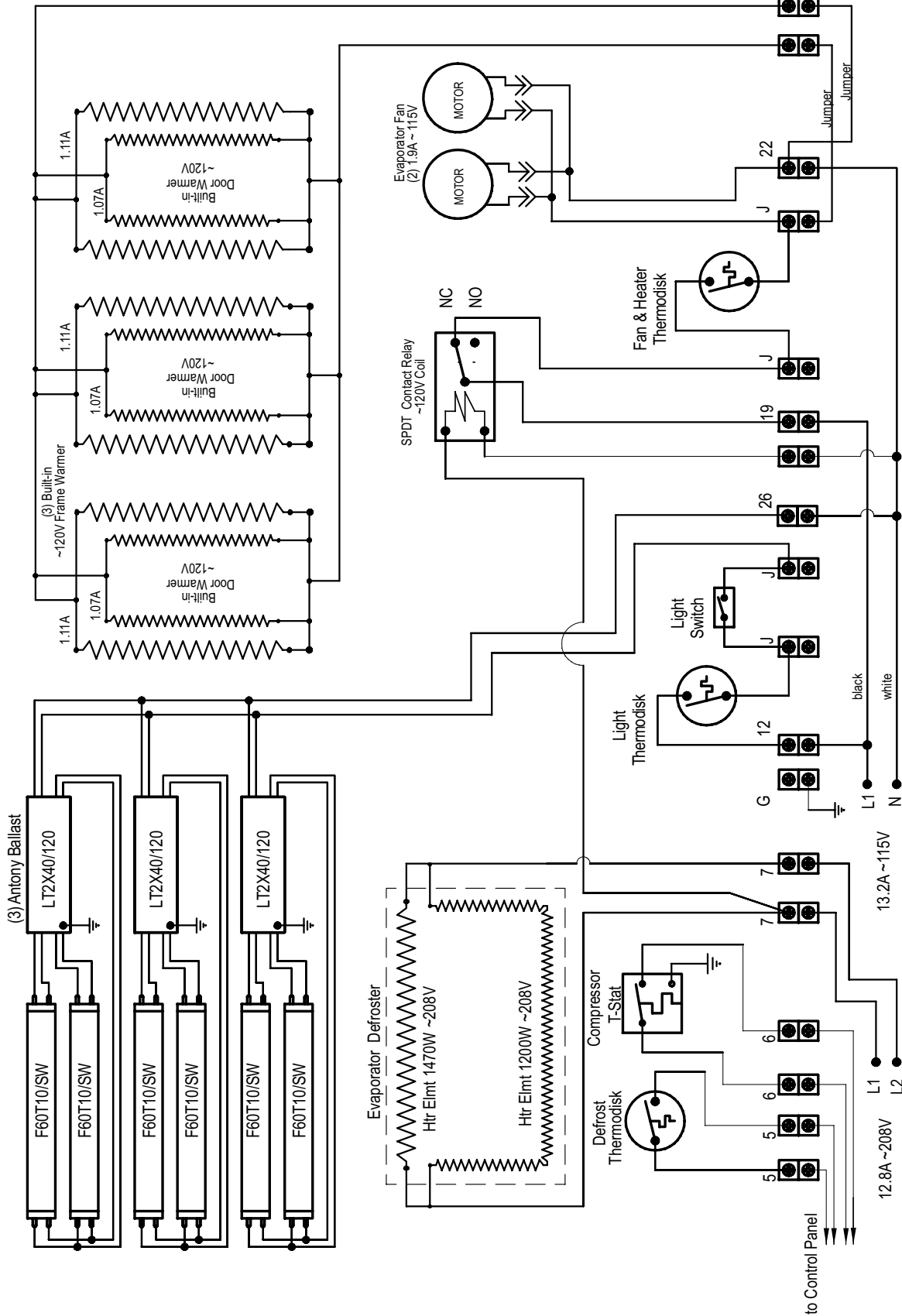

<b>HUSSMANN</b> Hussmann Corporation 13770 Ramona Avenue Chino, CA 91710 (909) 580-4910 Lic.#: 64440 6		Revisions: No. Description: _____ _____	Drawn By: _____ Checked By: _____ Date: _____ Next Assembly: _____	Project Title: <b>Refrigerated Low-Temp 3-Sided End Cap Display</b> Drawing Title: <b>RFED-6-7-8 Wiring Diagram</b>	Drawn No.: <b>W220000</b> Sheet 1 of 1
---	--	--	---	--	--

## Appendices

### APPENDIX A. – Temperature Guidelines Refrigerated

The refrigerators should be operated according to the manufacturer's published engineering specifications for entering air temperatures for specific equipment applications. Table 1 shows the typical temperature of the air entering the food zone one hour before the start of defrost and one hour after defrost for various categories of refrigerators. Refer to Appendix C for Field Evaluation Guidelines.

**TABLE 1**

TYPE OF REFRIGERATOR	TYPICAL ENTERING AIR TEMPERATURE
<b>I. OPEN DISPLAY</b>	
A. Non frozen:	
1) Meat	28°F
2) Dairy/Deli	32°F
3) Produce	
a. Processed	36°F
b. Unprocessed	45°F
B. Frozen	0°F
C. Ice Cream	-5°F
<b>II. CLOSED DISPLAY</b>	
A. Non frozen:	
1) Meat	34°F
2) Dairy/Deli	34°F
3) Produce	
a. Processed	36°F
b. Unprocessed	45°F
B. Frozen	0°F
C. Ice Cream	-5°F

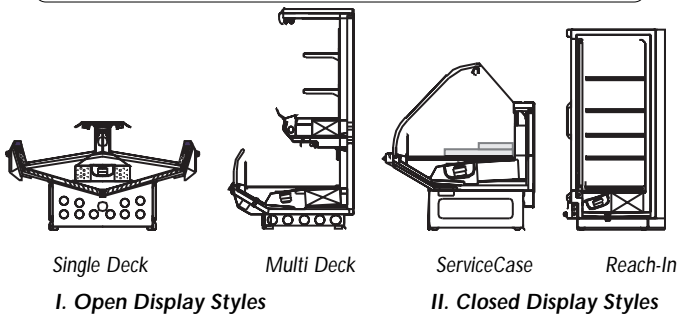

### APPENDIX B. – Application Recommendations Refrigerated

- 1.0 Temperature performance is critical for controlling bacteria growth. Therefore, the following recommendations are included in the standard. They are based on confirmed field experience over many years.
- 1.1 The installer is responsible for following the installation instructions and recommendations provided by the manufacturer for the

installation of each individual type refrigerator.

- 1.2 Refrigeration piping should be sized according to the equipment manufacturer's recommendations and installed in accordance with normal refrigeration practices. Refrigeration piping should be insulated according to the manufacturer's recommendations.
- 1.3 A clogged waste outlet blocks refrigeration. The installer is responsible for the proper installation of the system which dispenses condensate waste through an air gap into the building indirect waste system.
- 1.4 The installer should perform a complete start-up evaluation prior to the loading of food into the refrigerator, which includes such items as:
- Initial temperature performance, Coils should be properly fed with a refrigerant according to manufacturer's recommendations.
  - Observation of outside influences such as drafts, radiant heating from the ceiling and from lamps. Such influence should be properly corrected or compensated for.
  - At the same time, checks should be made of the store dry-bulb and wet-bulb temperatures to ascertain that they are within the limits prescribed by the manufacturer.
  - Complete start-up procedures should include checking through a defrost to make certain of its adequate frequency and length without substantially exceeding the actual needs. This should include checking the electrical or refrigerant circuits to make sure that defrosts are correctly programmed for all the refrigerators connected to each refrigeration system.
  - Recording instruments should be used to check performance.

### APPENDIX C. – Field Recommendations - Refrigerated

Recommendations for field evaluating the performance of retail food refrigerators and hot cases

- 1.0 The most consistent indicator of display refrigerator performance is temperature of the air entering the product zone (Refrigerated see Diagram 1, Appendix A). In practical use, the precise determination of return air temperature is extremely difficult. Readings of return air temperatures will be variable and results will be inconsistent. The product temperature alone is not an indicator of refrigerator performance.

**NOTE:** Public Health will use the temperature of the product in determining if the refrigerator will be allowed to display potentially hazardous food. For the purpose of this evaluation, product temperature above the FDA Food Code 1993 temperature for potentially hazardous food will be the first indication that an evaluation should be performed. It is expected that all refrigerators will keep food at the FDA Food Code 1993 temperature for potentially hazardous food.

- 1.1 The following recommendations are made for the purpose of arriving at easily taken and understood data which, coupled with other observations, may be used to determine whether a display refrigerator is working as intended:

- a) INSTRUMENT – A stainless steel stem-type thermometer is recommended and it should have a dial a minimum of 1 inch internal diameter. A test thermometer scaled only in Celsius or dually scaled in Celsius and Fahrenheit shall be accurate to 1°C (1.8°F). Temperature measuring devices that are scaled only in Fahrenheit shall be accurate to 2°F. The thermometer should be checked for proper calibration. (It should read 32°F when the stem is immersed in an ice water bath).
- b) LOCATION – The probe or sensing element of the thermometer should be located in the airstream where the air first enters the display or storage area, and not more than 1 inch away from the surface and in the center of the discharge opening.
- c) READING – It should first be determined that the refrigerator is refrigerating and has operated at least one hour since the end of the last defrost period. The thermometer reading should be made only after it has been allowed to stabilize, i.e., maintain a constant reading.
- d) OTHER OBSERVATIONS – Other observations should be made which may indicate operating problems, such as unsatisfactory product, feel/appearance.
- e) CONCLUSIONS – In the absence of any apparent undesirable conditions, the refrigerator should be judged to be operating properly. If it is determined that such condition is undesirable, i.e., the product is above proper temperature, checks should be made for the following:
  1. Has the refrigerator been loaded with warm product?
  2. Is the product loaded beyond the "Safe Load Line" markers?
  3. Are the return air ducts blocked?
  4. Are the entering air ducts blocked?
  5. Is a dumped display causing turbulent air flow and mixing with room air?
  6. Are spotlights or other high intensity lighting directed onto the product?
  7. Are there unusual draft conditions (from heating /air-conditioning ducts, open doors, etc.)?
  8. Is there exposure to direct sunlight?
  8. Are display signs blocking or diverting airflow?
  9. Are the coils of the refrigerator iced up?
  11. Is the store ambient over 75°F, 55% RH as set forth in ASHRAE Standard 72 and ASHRAE Standard 117?
  12. Are the shelf positions, number, and size other than recommended by the manufacturer?
  13. Is there an improper application or control system?
  14. Is the evaporator fan motor/blade inoperative?
  15. Is the defrost time excessive?
  16. Is the defrost termination, thermostat (if used) set too high?
  17. Are the refrigerant controls incorrectly adjusted?
  18. Is the air entering the condenser above design conditions? Are the condenser fins clear of dirt, dust, etc.?

19. Is there a shortage of refrigerant?
20. Has the equipment been modified to use replacements for CFC-12, CFC-502 or other refrigerant? If so, have the modifications been made in accordance with the recommendations of the equipment manufacturer? Is the refrigerator charged with the proper refrigerant and lubricant? Does the system use the recommended compressor?

#### **APPENDIX D. – Recommendations to user - Refrigerated**

- 1.0 The manufacturer should provide instructions and recommendations for proper periodic cleaning. The user will be responsible for such cleaning, including the cleaning of low temperature equipment within the compartment and the cooling coil area(s). Cleaning practices, particularly with respect to proper refrigerator unloading and warm-up, must be in accordance with applicable recommendations.
- 1.1 Cleaning of non frozen food equipment should include a weekly cleaning of the food compartment as a minimum to prevent bacteria growth from accumulating. Actual use and products may dictate more frequent cleaning. Circumstances of use and equipment design must also dictate the frequency of cleaning the display areas. Weekly washing down of the storage compartment is also recommended, especially for equipment subject to drippage of milk or other liquids, or the collection of vegetable, meat, crumbs, etc. or other debris or litter. Daily cleaning of the external areas surrounding the storage or display compartments with detergent and water will keep the equipment presentable and prevent grime buildup.
- 1.2 Load levels as defined by the manufacturer must be observed.
- 1.3 The best preservation is achieved by following these rules:
  - a) Buy quality products.
  - b) Receive perishables from transit equipment at the ideal temperature for the particular product.
  - c) Expedite perishables to the store's storage equipment to avoid unnecessary warm-up and prolonged temperature recovery. Food store refrigerators are not food chillers nor can they reclaim quality lost through previous mishandling.
  - d) Care must be taken when cross merchandising products to ensure that potentially hazardous vegetable products are not placed in non refrigerated areas.
  - e) Display and storage equipment doors should be kept closed during periods of inactivity.
  - f) Minimize the transfer time of perishables from storage to display.
  - g) Keep meat under refrigeration in meat cutting and processing area except for the few moments it is being handled in processing. When a cut or tray of meat is not to be worked on immediately, the procedure should call for returning it to refrigeration.
  - h) Keep tools clean and sanitized. Since mechanical equipment is used for fresh meat processing, all such equipment should be cleaned at

least daily and each time a different kind of meat product comes in contact with the tool or equipment.

- i) Make sure that all refrigeration equipment is installed and adjusted in strict accordance with the manufacturer's recommendations.
- j) See that all storage and refrigeration equipment is kept in proper working order by routine maintenance.

# **HUSSMANN®**

## **Limited Warranty**

**This warranty is made to the original user at the original installation site and is not transferable.**

Hussmann merchandisers are warranted to be free from defect in material and workmanship under normal use and service for a period of one (1) year from the date of original installation (not to exceed fifteen (15) months from the date of shipment for the factory). **Hussmann Impact Modular Coils are warranted for a total of five (5) years based upon the above criteria.** Hussmann's obligation under this warranty shall be limited to repairing or exchanging any part or parts, without charge F.O.B. factory or nearest authorized parts depot within said period and which is proven to the satisfaction of the original manufacturing plant warranty group to be thus defective.

Hussmann covers the entire case or refrigeration product and all its components (except for lamps, driers, fuses, and other maintenance type replacement parts) for the one (1) year warranty period.

Additionally, Hussmann warrants for a total period of three (3) years all sealed, multi-glass assemblies except those used in sliding doors on closed meat display cases. If within three (3) years from the date of installation (not to exceed thirty-nine (39) months from the date of shipment from factory), it shall be proven to the satisfaction of the originating factory warranty group that there is impaired visibility through the multi-glass assemblies thereof caused by moisture between the glasses, the multi-glass assembly will be replaced free of charge, F.O.B. factory. This additional warranty excludes accident, misuse, or glass breakage.

On Hussmann manufactured self-contained display cases, Hussmann agrees to repair or exchange, at its option, the original motor/compressor unit only with a motor/compressor of like or of similar design and capacity if it is shown to the satisfaction of Hussmann that the motor/compressor is inoperative due to defects in factory workmanship or material under normal use and service as outlined in Hussmann's "Installation Instructions" which are shipped inside new Hussmann equipment. Hussmann's sole obligation under this warranty shall be limited to a period not to exceed five years from date of factory shipment.

On Hussmann refrigeration systems, an additional (4) year extended warranty for the motor/compressor assembly is available, but must be purchased prior to shipment to be in effect. Hussmann reserves the right to inspect the job site, installation and reason for failure.

The motor/compressor warranties listed above do not include replacement or repair of controls, relays, capacitors, overload protectors, valve plates, oil pumps, gaskets or any external part on the motor/compressor replaceable in the field, or any other part of the refrigeration system or self-contained display case.

THE WARRANTIES TO REPAIR OR REPLACE ABOVE RECITED ARE THE ONLY WARRANTIES, EXPRESS, IMPLIED OR STATUTORY, MADE BY HUSSMANN WITH RESPECT TO THE ABOVE MENTIONED EQUIPMENT, INCLUDING ANY IMPLIED WARRANTY OF MERCHANTABILITY OR FITNESS, AND HUSSMANN NEITHER ASSUMES NOR AUTHORIZES ANY PERSON TO ASSUME FOR IT, ANY OTHER OBLIGATION OR LIABILITY IN CONNECTION WITH THE SALE OF SAID EQUIPMENT OR ANY PART THEREOF.

**THIS WARRANTY SHALL NOT APPLY TO LOSS OF FOOD OR CONTENTS OF THE EQUIPMENT DUE TO FAILURE FOR ANY REASON. HUSSMANN SHALL NOT BE LIABLE:**

- For payment of labor for any removal or installation of warranted parts;
- For any repair or replacements made without the written consent of Hussmann, or when the equipment is installed or operated in a manner contrary to the printed instructions covering installation and service which accompanied such equipment;
- For any damages, delays, or losses, direct or consequential which may arise in connection with such equipment or part thereof;
- For damages caused by fire, flood, strikes, acts of God or circumstances beyond its control;
- When the equipment is subject to negligence, abuse, misuse or when the serial number of the equipment has been removed, defaced, or altered;
- When the equipment is operated on low or improper voltages
- When the equipment is put to a use other than normally recommended by Hussmann (i.e. deli case used for fresh meat);
- When operation of this equipment is impaired due to improper drain installation;
- For payment of refrigerant loss for any reason;
- For costs related to shipping or handling of replacement parts.

**Hussmann Corporation, Corporate Headquarters: Bridgeton, Missouri, U.S.A. 63044 August 1, 1998**



---

## Service Record

Last service date:    By:

_____	_____
_____	_____
_____	_____
_____	_____
_____	_____
_____	_____
_____	_____
_____	_____

---

## **HUSSMANN**<sup>®</sup>/Chino

Additional copies of this publication may be obtained by contacting:

Husmann<sup>®</sup> Chino

13770 Ramona Avenue • Chino, California 91710

(909) 628-8942 FAX

(909) 590-4910

(800) 395-9229

The *MODEL NAME* and *SERIAL NUMBER* is required in order to provide you with the correct parts and information for your particular unit.

They can be found on a small metal plate on the unit.

Please note them below for future reference.

**MODEL:**

**SERIAL NUMBER:**