



SELF-SERVICE DELI TYPE II
HUSSMANN - TY-4 I-ISLAND, E-END SELF-CONTAINED (CHINO)

REVISION DATE

10/09/19



Hussmann refrigerated merchandisers configured for sale for use in the United States meet or surpass the requirements of the DOE 2017 energy efficiency standards.

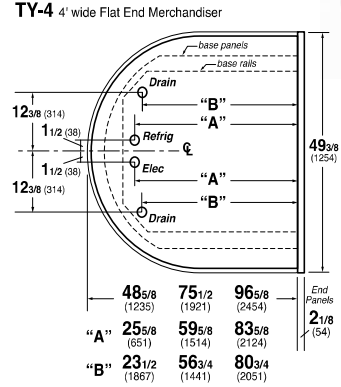
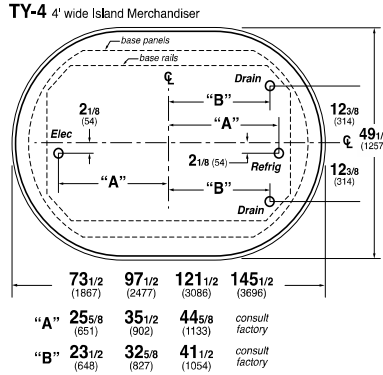
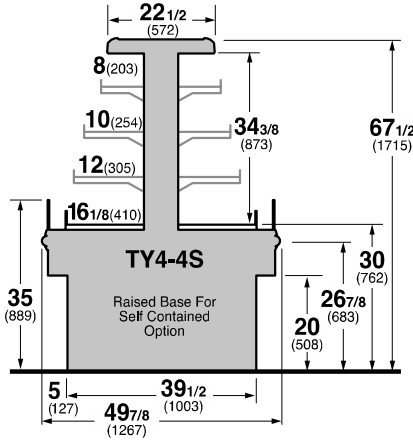

REFRIGERATION DATA:

CASE LENGTHS	CASE USAGE	CONVENTIONAL CAPACITY ** (BTU/HR/FT)	DISCHARGE AIR * (°F) (SEE SETPOINTS BELOW)	VELOCITY (FT/MIN)
6I,8I,10I	DELI	2300	28-32	100~150
4E,6E,8E	DELI	1950	28-32	100~150

*FRONT DISCHARGE AIR MEASURED INSIDE AIR CURTAIN HONEYCOMB

**REFRIGERATION NOTES:

- 1) CAPACITY FOR REFERENCE ONLY
- 2) RATING CONDITION IS NSF TYPE II, 80°F/55% RH

REFRIGERATION DATA CONTINUED:

CONTROLLER / AIR SENSOR SETTINGS		DEFROST TYPE	FAIL-SAFE TIME (MIN)	DEFROST FREQ. (#/DAY)	TERM. TEMP (°F) AIR	DRIP TIME (MIN)	DEFROST WATER (LBS/DAY/FT)
USAGE	SET POINT (°F)						
DELI	23	10	OFF TIME	50	6	52	NA

END PANEL WIDTH KEY		
# OF END PNLS	END PNL WIDTH (IN.)	TOTAL ADDED LENGTH (IN.)
1	1.125	1.125

4) DEFROST IS BASED ON TERMINATION TEMP, WHICH UNDER NORMAL CIRCUMSTANCES, IS SHORTER THAN FAILSAFE TIME.

ELECTRICAL DATA:

STANDARD FANS, HEATERS, LED LIGHTS (115 VOLT)

CASE LENGTH	EVAPORATOR FANS					CANOPY LIGHTS LED		OPTIONAL LED SHELF LIGHTS		MAX. LED LOAD (W/ ALL OPTIONS)		ANTI-SWEAT HEATERS		CONVENIENCE OUTLETS (OPTIONAL)			LIGHT MATRIX
	# OF EVAP FANS	BLADE DIA. (IN.)	BLADE PITCH (°)	AMPS	WATTS	AMPS	WATTS	AMPS	WATTS	AMPS	WATTS	AMPS	WATTS	# OUTLETS	VOLTS	AMPS	
6I	6	8	15	1.8	48	0.1	14	0.4	52	0.6	66	0.4	50	1	115	15	26
8I	6	8	20	1.8	48	0.2	25	0.7	84	0.9	109	0.6	70	1	115	15	42
10I	8	8	15	2.4	64	0.3	35	1.0	113	1.3	148	0.8	90	1	115	15	58
4E	4	8	20	1.2	32	0.1	12	0.4	41	0.5	53	0.3	40	1	115	15	22
6E	6	8	15, 20	1.8	48	0.2	23	0.6	73	0.8	96	0.5	60	1	115	15	38
8E	8	8	20	2.4	64	0.3	33	0.9	102	1.2	135	0.7	80	1	115	15	54

CONDENSING UNIT AND EVAPORATIVE PANS

CASE LENGTH	NOM. HP	CONDENSING UNIT				EVAPORATIVE PAN			PLUG TYPE	EST. REFG. CHR.G. (LBS)
		REFRIG.	HZ/PH	VOLTS	RLA	VOLTS	AMPS	WATTS		
6I	2 1/4	R-404A	60 / 1	240	15.7	240	6.3	1500	CS-6365-C	2.5
8I	3		60 / 1	240	18.0	208	9.6	2000	CS-6365-C	2.5
10I	3 1/2		60 / 1	240	23.6	208	9.6	2000	CS-6365-C	3.0
4E	1		60 / 1	240	10.0	208	7.2	1500	L14-30P	2.0
6E	2		60 / 1	240	12.0	240	6.3	1500	L14-30P	2.5
8E	2 1/2		60 / 1	240	17.9	208	9.6	2000	CS-6365-C	3.0
6I	2 1/4	R-448A	60 / 1	240	15.7	240	6.3	1500	CS-6365-C	2.5
8I	3		60 / 1	240	18.0	208	9.6	2000	CS-6365-C	2.5
10I	3 1/2		60 / 1	240	23.6	208	9.6	2000	CS-6365-C	3.0
4E	1		60 / 1	240	9.3	208	7.2	1500	L14-30P	2.0
6E	2		60 / 1	240	12.0	240	6.3	1500	L14-30P	2.5
8E	3 1/4		60 / 1	240	23.2	208	9.6	2000	CS-6365-C	3.0

OPTIONAL HIGH OUTPUT LED LIGHTS (115 VOLT)

CASE LENGTH	CANOPY LIGHTS H.O. LED		OPTIONAL SHELF		MAX. H.O. LED LOAD	
	AMPS	WATTS	AMPS	WATTS	AMPS	WATTS
6I	N/A	N/A	N/A	N/A	N/A	N/A
8I	N/A	N/A	N/A	N/A	N/A	N/A
10I	N/A	N/A	N/A	N/A	N/A	N/A
4E	N/A	N/A	N/A	N/A	N/A	N/A
6E	N/A	N/A	N/A	N/A	N/A	N/A
8E	N/A	N/A	N/A	N/A	N/A	N/A